

### INTRODUCTION

In most installations, the Mini-Clik acts as a switch to break the circuit to the solenoid valves of the irrigation system when it has rained. This allows the timer to advance as scheduled, but keeps the valves from opening the water flow. Once the Mini-Clik has dried sufficiently, the switch closes again to allow for normal operation.

The Mini-Clik has two blue wires connected to a 25 foot extension.

For the Model Mini-Clik-C: This rain sensor unit is the same as the standard model except for the lack of an aluminum mounting bracket and the addition of a 1/2" threaded cap, which allows for the easy use of electrical conduit to totally enclose the wires. Unless local code states otherwise, plumbing grade PVC pipe can be used as well as electrical grade conduit.

For the Model Mini-Clik-HV: This rain sensor unit is designed to be used with automatic irrigation systems of two principle designs: 1) single-station electrical timer (e.g., Intermatic) that switches power to a pump, either directly or through a relay; or 2) single-station electrical timer that switches power to a solenoid valve.

### MOUNTING

**Standard Model:**

Using the screws provided, mount the Mini-Clik on any surface where it will be exposed to unobstructed rainfall, but not in the path of sprinkler spray. The switch-housing portion must be upright (as pictured), but the swivel-bracket can be moved for mounting on any angled surface. Loosen the locknut and screw before swiveling bracket, and then re-tighten.

**For the Conduit Model Mini-Clik-C:**

The conduit acts as the mounting support for the unit. Therefore, place and mount the conduit to allow for the desired sensor location as described in the main instructions for the standard model. Be sure to support the conduit sufficiently along its various lengths.

**For the High-Voltage Model Mini-Clik-HV:**

The mounting of this unit is primarily made by screwing the fitting end into the threaded holes of covers to rectangular junction boxes (for outdoor use) or the covers of round junction boxes commonly used for outdoor spotlights. Locate the junction box so that with the Mini-Clik attached, unobstructed rainfall will hit the outermost sensing end of the unit. If a longer reach substituted with a slightly 1 1/2" with support).

Helpful hints for mounting:

- When looking for a suitable location such as on the side of a building or post, the closer the Mini-Clik is to the controller, the shorter the wire run will be. This will also minimize the chance for wire breaks.
- The ideal location for mounting is not always the most practical location. In the case where a compromise must exist (such as low location on a side wall rather than the preferred high location), note that the Mini-Clik will still work as it will always receive some rainfall – it just will not be as accurate in its gauging as it could be.

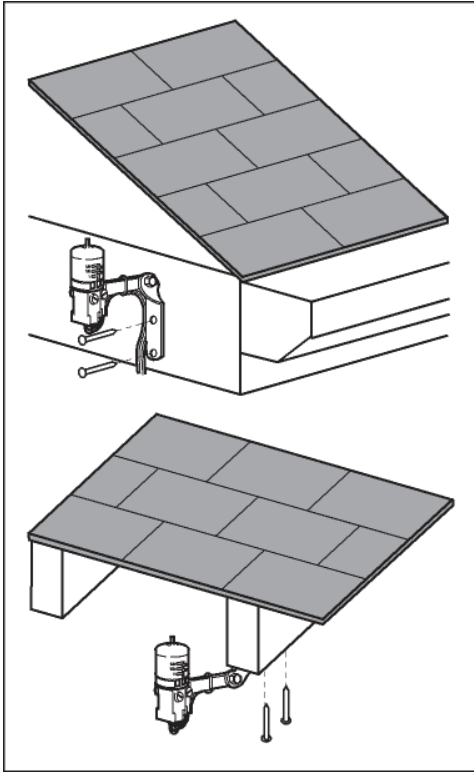

is needed, the "Carlon" flexible conduit piece can be longer piece (up to 8" length with no support or up to

- As described in the "Operation" section of this manual, "reset rate" refers to the amount of time it takes the Mini-Clik to dry out sufficiently for the sprinkler system to be allowed to come back on. The mounting location will affect this rate and should be taken into consideration should extreme conditions exist. For example, mounting the Mini-Clik on a very sunny, southern end of a building may cause the Mini-Clik to dry out sooner than desired. Similarly, mounting on the northern end of a building with constant shade may keep the Mini-Clik from drying soon enough.

Once the Mini-Clik is mounted, run the wire to the controller, and fasten it every few feet with wire clips or stapled for best results. If an extension to the wire provided is needed, use the following table to determine the minimum wire gauge needed:

If the extension needed is:	25-50 ft.	50-100 ft.	100 ft. or more
use:	20 AWG	18 AWG	16 AWG

### WIRING TO YOUR IRRIGATION SYSTEM

**Important:** The Standard Model Mini-Clik is sold and designed for hook up to 24 Volt irrigation controllers only. For wiring to 110V or 220V irrigation controllers, please consult your distributor or this factory. All wiring must conform to National Electrical Code or applicable local codes.

**For the Model Mini-Clik-C: WARNING!** This unit is designed to be installed in conjunction with 24VAC circuits only. Do not use with 110 or 220VAC circuits.

**For the Model Mini-Clik-HV: WARNING!** This unit must be installed by a qualified electrician in accordance with National Electrical Code and applicable local codes. The electrical rating of this device is 125-250VAC at 10.1 amps. Do not let current pass through this device that exceeds this rating. Do not install directly in line with any pump.

**Wiring to the Hunter SRC**

The Mini-Clik connects directly to the SRC. This allows you to easily override the sensor by using the RUN (BYPASS SENSOR) position on the dial.

- Route the wires from the Mini-Clik up through the same opening used for valve wiring.
- Connect one wire to the RS terminal and other to the C terminal (See Figure 1).
- Connect the valve common to the RS terminal.

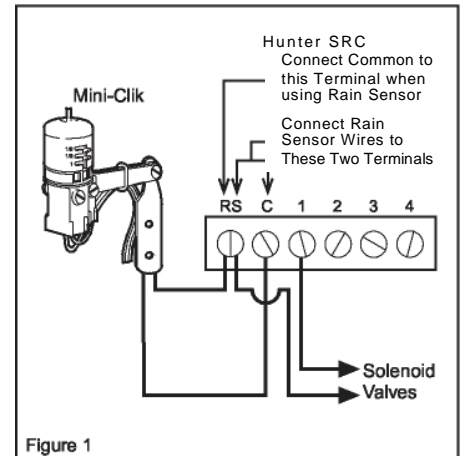

Figure 1

**Wiring to the Hunter ICC**  
The Mini-Clik connects directly to the ICC. This allows you to easily override the sensor by using the Sensor switch on the front panel.

- Remove the jumper from the two "SEN" terminals.
- Route the wires from the rain sensor up through the same conduit opening used for valve wiring.
- Connect one wire to the terminal labeled "SEN" and the other wire to the other "SEN" terminal (See Figure 2).

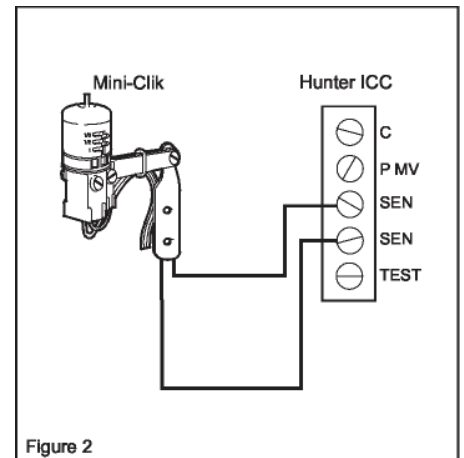

Figure 2

### Other Controllers

The two most common situations are shown below. For non-standard wiring situations, please consult your distributor or request our "Non-standard" wiring information packet.

#### A. 24 Volt Solenoid Valves Only (No booster pump) (See Figure 3)

With the two wires from the Mini-Clik at the controller, locate the "common ground" wire of the solenoid valves. If it is connected to the common terminal on the controller, disconnect it. Attach one wire of the Mini-Clik to the "common" terminal (usually marked "C") on the controller. Attach the other wire of the Mini-Clik to the common wire leading to the valves. Note: The common wire to the valves does not have to be interrupted at the controller. The Mini-Clik may be wired anywhere along the common wire line.

#### B. 24 Volt Solenoid Valves with Booster Pump (See Figure 4)

Locate the common wire to the solenoid valves and the common wire leading to the coil of the relay that starts the pump. If these two wires are connected to the "common" terminal on the controller, disconnect both of them.

Twist together these two wires along with one wire from the Mini-Clik, and secure with a wire nut. Attach the other wire of the Mini-Clik to the "common" terminal on the controller. Note: The pump circuit output must be 24 Volts in this situation. Do not proceed if 110V.

#### C. Special Instructions for Mini-Clik-HV (See Figures 5 and 6)

The two taped and stripped wires are the ones to be used when following these accompanying diagrams. The third wire should be terminated with a wire nut (not supplied). All wire connections with the Mini-Clik should be made with wire nuts and located in a junction box.

Where the timer is controlling a pump, the relay may be inside the

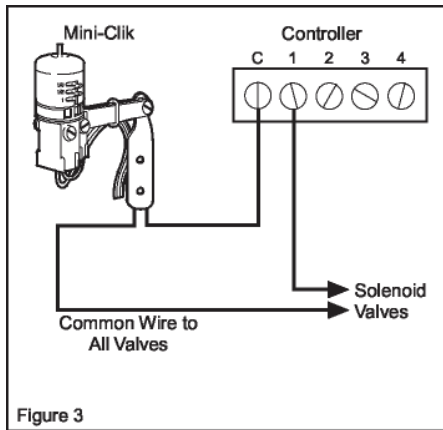

Figure 3

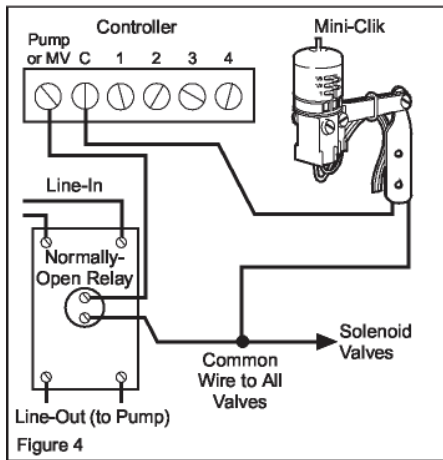

Figure 4

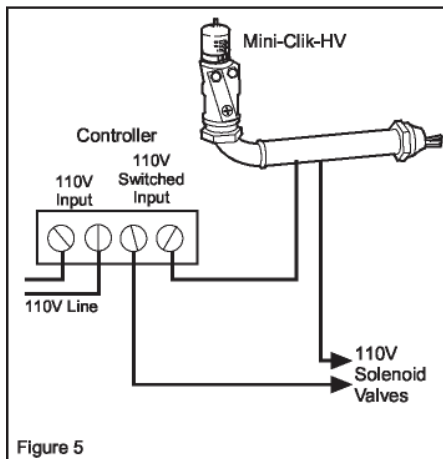

Figure 5

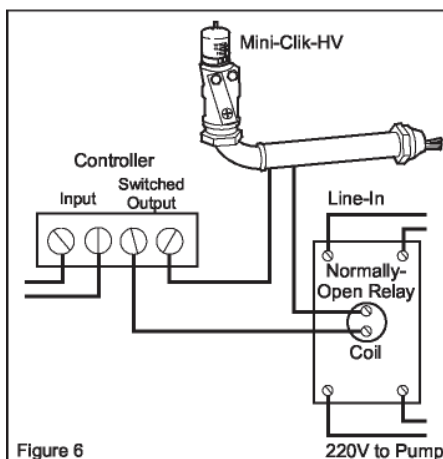

Figure 6

timer, external or non-existent. If there is no relay in the circuit, one must be added. The wiring for an internal or external relay is the same: the Mini-Clik breaks the circuit to the coil of the relay only. Either wire of the coil may be broken.

### Operation Check to Verify Correct Wiring

Turn on one zone of the irrigation system that is visible while you are in reach of the Mini-Clik. Manually depress the spindle at the top of the Mini-Clik until you hear the switch "click" off. The sprinkler zone should stop instantaneously. If it does not, check wiring for correctness. It is not necessary to "wet" test the Mini-Clik, although it will test the operation fine, if desired.

### ADJUSTMENTS AND OPERATION

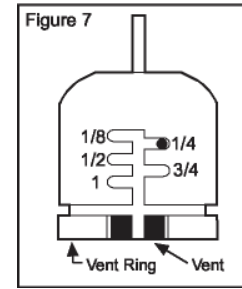

The Mini-Clik can keep the irrigation system from starting or continuing after rainfall quantities of  $\frac{1}{8}$ ",  $\frac{1}{4}$ ",  $\frac{1}{2}$ ",  $\frac{3}{4}$ " or 1". To adjust it to the desired shut-off quantity, rotate the cap on the switch housing so that the pins are located in the proper slots (see Figure 7). Do not forcibly twist the cap as this might break the pins.

The time that it takes the Mini-Clik to reset for normal sprinkler operation after the rain has stopped is determined by weather conditions (wind, sunlight, humidity, etc.) These conditions will determine how fast the hygroscopic discs dry out, and since the turf is also experiencing the same conditions, their respective drying rates will roughly parallel each other.

So when the turf needs more water, the Mini-Clik is already reset to allow the sprinkler system to go at the next scheduled cycle.

There is an adjustment capability on the Mini-Clik that will slow down the reset rate. By turning the "vent ring" (see Figure 7) to completely or partially cover the ventilation holes, the hygroscopic discs will dry more slowly. This adjustment can compensate for an "overly sunny" installation location, or peculiar soil conditions. Experience will best determine the ideal vent setting.

### BYPASSING THE SENSOR

The Hunter ICC and SRC controllers are equipped with a built-in bypass that allows you to override an active sensor. For controllers not equipped with this feature, should you desire to bypass the operation of the Mini-Clik for any reason (i.e., turn on your system even though the Mini-Clik has shut "off" due to rainfall), there are two simple ways to do this. The first is to add our Bypass Switch Box. This mounts on or next to the controller, and by simply moving the switch, the Mini-Clik is bypassed. The second method is to go to the Mini-Clik and raise the "cap" a couple of settings higher or completely remove it. This takes the pressure off the switch button, which allows the valve circuit to close again.

Note: Using the "manual" switch on non-Hunter controllers typically will not bypass the sensor.

### MAINTENANCE

There is no required maintenance for the unit. The Mini-Clik does not have to be removed or covered for "winterizing" purposes.

### Troubleshooting

Follow these simple checks first before assuming the unit is bad and replacing it.

System will not come on at all:

- First, check to see that the Mini-Clik discs are dry and the switch "clicks" on and off freely by pressing the top of the spindle.
- Next, look for breaks in the wire leading to the Mini-Clik and check all wire junctions.
- Finally, if the Mini-Clik is dry and the wire leading to it is good, check the Mini-Clik switch by nicking the insulation of the two "outer" wires near the unit to expose copper. Turn one sprinkler zone on, and apply a "jumper wire" across the two exposed wires. If the sprinkler now comes on, the switch is bad. Wrap all nicked wires with electrical tape.

System will not shut off even after heavy rainfall:

- Check wiring for correctness (see "Operation Check to Verify Correct Wiring").
- Check sensitivity setting on Mini-Clik – move cap to more sensitive setting. The Mini-Clik is an accurate rain gauge and can be verified by setting up a "tube" type rain gauge in the same vicinity and making periodic readings.
- Is the rainfall actually hitting the Mini-Clik? Check for obstructions to rainfall such as overhangs, trees or walls.

Manufactured under U.S. Patent No. 3,808,385.

All Mini-Clik models are listed by Underwriters Laboratories, Inc. (UL). Samples of these devices have been evaluated by UL and meet the applicable UL standards for safety.