

APPLICATIONS

The AP35B and AP50B submersible pumps are specially designed for lifting domestic sewage or any other non-aggressive liquid containing solid matter up to 50 mm. They can be installed vertically or horizontally.

FEATURES

- Single-phase models supplied with float switch and standard electric plug
- Auto Coupling available as an accessory for installation on a guide bar enabling positioning/removal of the pump from outside the hole
- Solid handling capacity: 35 mm for AP35B and 50 mm for AP50B
- Unique clip assembly system enabling immediate access to the impeller without disassembly tools
- Easy service of the power cable and float

CONSTRUCTION

- Stainless steel volute, pump housing and impeller
- IP68 motor
- Insulation Class F
- Vortex impeller
- Silicon carbide mechanical seal
- Voltage: 240 V with float switch (A1) or 3 x 415 V

TECHNICAL FEATURES

| Pumps | Cable (m) | P2 (kW) | 1 ph In (A) | 3 ph In (A) | Water temp (°C) | Outlet | Dimensions (mm) | | | | | Performance | | | | | | |
|------------------------|-----------|---------|-------------|-------------|-----------------|--------|-----------------|-----|----|-----|-----|-------------------|------|------|------|------|-----|-----|
| | | | | | | | A | C | D | d1 | d2 | l/min | 0 | 100 | 200 | 300 | 400 | 500 |
| | | | | | | | | | | | | m ³ /h | 0 | 6 | 12 | 18 | 24 | 30 |
| Unilift AP35B-50-06-A1 | 10 | 0.66 | 4.0 | - | 0/40 | 2" F | 443 | 116 | 73 | 234 | 210 | | 10.5 | 7.4 | 4.5 | 1.7 | - | - |
| Unilift AP35B-50-08-A1 | 10 | 0.71 | 5.5 | - | 0/40 | 2" F | 468 | 116 | 73 | 234 | 210 | | 12.5 | 9.4 | 6.8 | 3.4 | - | - |
| Unilift AP50B-50-08-A1 | 10 | 0.74 | 5.4 | - | 0/40 | 2" F | 443 | 116 | 73 | 234 | 210 | m Head | 11.0 | 8.9 | 6.7 | 4.5 | 2.8 | - |
| Unilift AP50B-50-11-A1 | 10 | 1.10 | 8.0 | - | 0/40 | 2" F | 468 | 116 | 73 | 234 | 210 | | 14.0 | 11.5 | 9.5 | 7.2 | 4.9 | - |
| Unilift AP50B-50-11-3 | 5 | 1.30 | - | 2.8 | 0/40 | 2" F | 468 | 116 | 73 | 234 | 210 | | 14.3 | 12.1 | 10.0 | 7.8 | 5.5 | - |
| Unilift AP50B-50-15-3 | 5 | 1.50 | - | 3.0 | 0/40 | 2" F | 468 | 116 | 73 | 234 | 210 | | 18.3 | 15.2 | 12.8 | 10.2 | 7.6 | 5.0 |

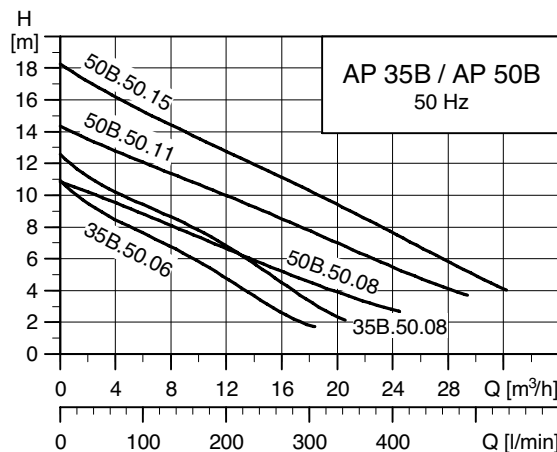

DIMENSIONS / INSTALLATION

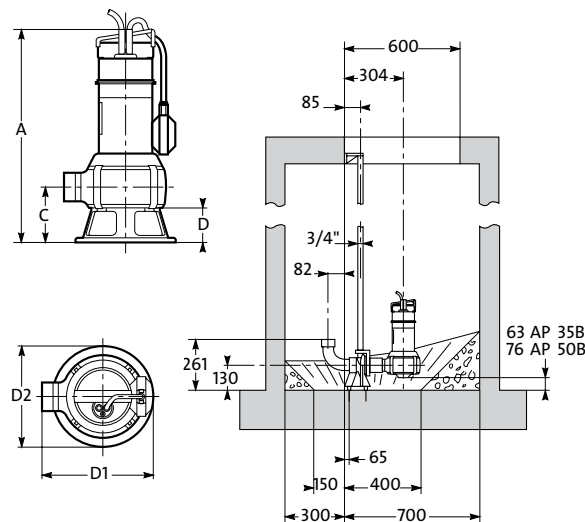

Installation depth: max. 10 m below the water level.
In continuous operation the pump must be continuously submerged.

Installation with Auto Coupling

- 1 Pump
- 2 Non-return valve
- 3 Lifting chain
- 4 Auto Coupling
- 5 Isolation valve
- b Guide bar

