

APPLICATIONS

The Grundfos CM Booster is a horizontal multistage centrifugal pump designed for domestic and light industrial applications. It is suitable for pressure boosting from above ground rainwater tanks or from mains water.

FEATURES



- Quiet operation
- Compact design
- Robust construction
- Dry run protection
- Easy installation
- Adjustable cut in pressure (PM2)
- Generator friendly

CONSTRUCTION

- All wetted parts stainless steel
- Hard wearing carbon / ceramic seal
- IP55 Motor
- Complies with AS/NZS 4020 - testing for products for use with drinking water

PERFORMANCE

Pumps	Discharge Pressure (kPa/psi)						
	150	200	250	300	350	400	450
	22	29	36	44	51	58	65
Output (l/min)							
CMB 1-4	40	33	26	18	-	-	-
CMB 3-3	65	50	26	-	-	-	-
CMB 3-4	-	63	53	38	20	-	-
CMB 3-5	-	69	61	52	41	26	-
CMB 3-6	-	-	68	63	55	47	36
CMB 5-3	99	79	44	-	-	-	-
CMB 5-4	-	100	85	67	30	-	-
CMB 5-5	-	-	102	92	80	62	24

As a guide 1 tap  = 10 litres per minute • 1 sprinkler  = 15 litres per minute

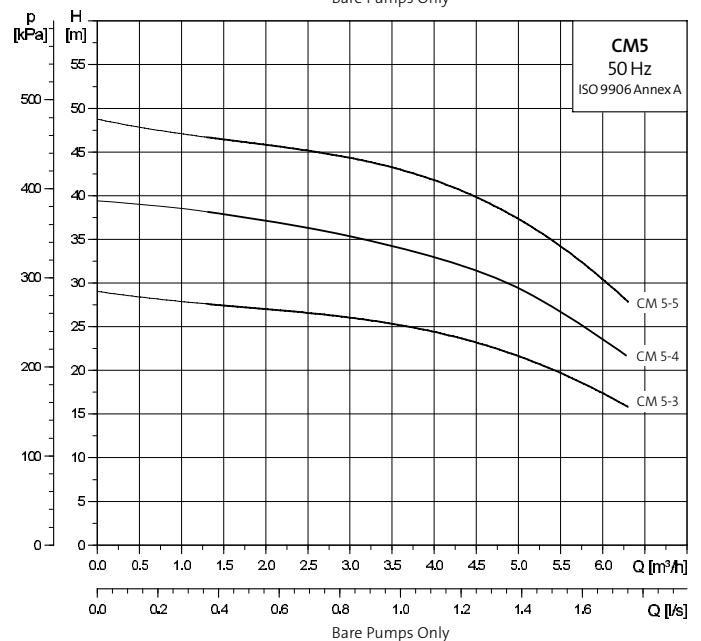
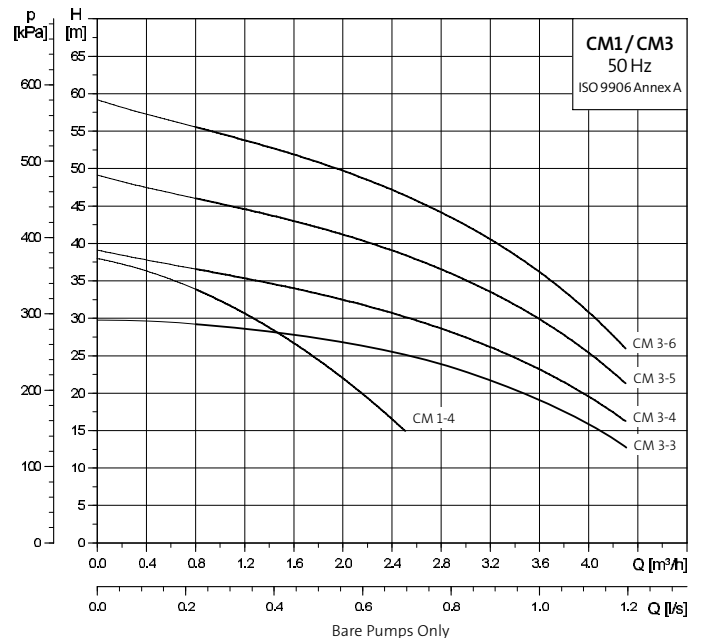

INSTALLATION

NOTE: Pump must be mounted in a pump shed or building.

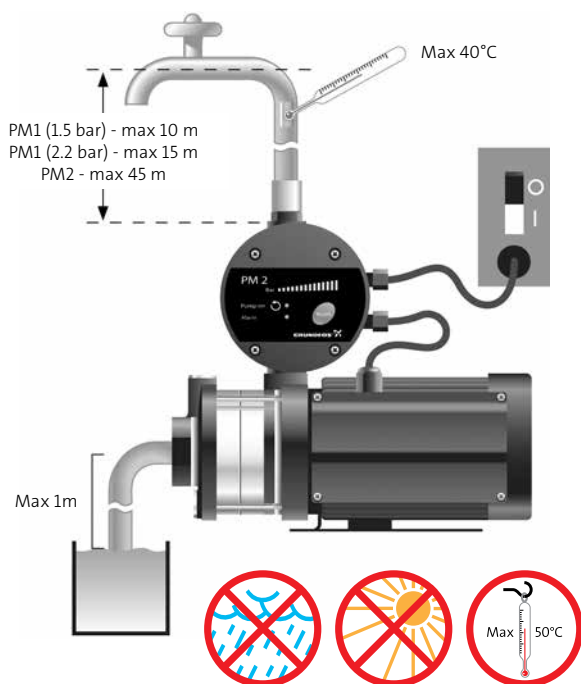

DIMENSIONS

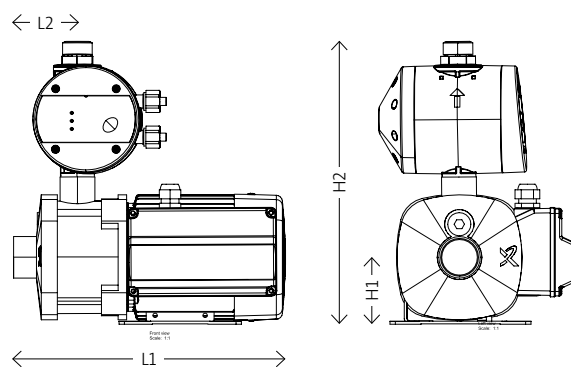

PRESSURE MANAGER COMPARISON

Model	PM 1	PM 2
Power on indication	•	•
Pump running indication	•	•
Alarm indication	•	•
Dry-running protection	•	•
Free position in installation	•	•
Suitable for generator supply	•	•
Rotary outlet connection	•	•
Integrated non-return valve	•	•
Cycling alarm	•	•
Integrated pressure sensor from Grundfos Direct Sensors™		•
Adjustable start pressure		•
Start / stop with 1 bar differential pressure		•
Auto restart after dry running		•
Max. run time 30 min. (safety)		•
Pressure indication		•
Internal pressure tank		•

SELECTION

Current CH-PC Model	Suitable Replacement CM Booster**
CH2-30 PC	CMB 1-4
CH2-40 PC	CMB 3-3
CH2-50 PC	CMB 3-4
CH2-60 PC	CMB 3-5
CH2-60 PC	CMB 3-6
CH4-40 PC	CMB 5-3
CH4-50 PC	CMB 5-4
CH4-60 PC	CMB 5-5

**calculated at 3 bar

TECHNICAL FEATURES

Model	P2 (kW)	1ph In (A)	Water Temp	Connection Size Inlet (A2)	Connection Size Outlet (A1)	Dimensions (mm)				Control	Weight (kg)	CH Equivalent	
						L1	L2 (centre of PM to outlet)	H2	H1				B2 (bolt hole centres)
CMB 1-4	0.5	3.1	0/40°C	1" F	1" M	323	89.5	317	75	125	PM1	13.8	CH2-30PC
CMB 3-3	0.5	3.1	0/40°C	1" F	1" M	5.5	71.5	317	75	125	PM2	13.6	CH2-40PC
CMB 3-4	0.5	3.1	0/40°C	1" F	1" M	323	89.5	317	75	125	PM2	14.0	CH2-50PC
CMB 3-5	0.5	3.1	0/40°C	1" F	1" M	341	107.5	317	75	125	PM2	14.4	CH2-60PC
CMB 3-6	0.67	4.4	0/40°C	1" F	1" M	417	143.5	317	75	125	PM2	16.34	CH2-60PC
CMB 5-3	0.5	3.1	0/40°C	1½" F	1" M	305	71.5	317	75	125	PM2	13.6	CH4-40PC
CMB 5-4	0.67	4.4	0/40°C	1½" F	1" M	363	89.5	317	75	125	PM2	15.3	CH4-50PC
CMB 5-5	0.9	5.4	0/40°C	1½" F	1" M	381	107.5	317	75	125	PM2	16.8	CH4-60PC