

CME Booster / CME TWIN Booster



A variable speed pump that adjust accordingly to water demand, resulting in lower running costs. All wetted components are constructed from high quality stainless steel ensuring, the water quality is not affected by pump materials. The pump will provide constant pressure at the tap (up to pump capacity), regardless of variation in demand or inlet pressure.

The CME TWIN Booster system consists of two CME Boosters connected in parallel and mounted on a common base plate.



FEATURES

Robust design

All wetted parts are made from high quality stainless steel to ensure the longest life possible.

Energy saving

The frequency controller of the CME Booster matches the power consumption with the required water output, helping to conserve energy.

Easy installation

The CME Booster is very easy to install. Once the booster has been connected to the pipework, it is simply a matter of putting the plug into a socket, and the system is operational.

Quiet operation

The CME Booster operates quietly, at around 55 decibels, significantly quieter than most pumps currently available on the market.

User-friendly interface

The user-friendly interface features LED indicators showing operational status and buttons for pressure adjustment.

Protective features

The CME Booster features dry run protection to automatically stop the pump if the water source runs out. The pump is also protected against any accidental overload by built-in thermal protection. These protective features help to ensure the longest life possible.

Cascade Control

CME TWIN Booster cascade control ensures that the performance automatically adapts to demand by switching pumps on or off and by changing the speed of the pumps in operation.

Automatic pump alternation

CME TWIN Booster automatically alternates the pumps so the operating demand of each pump is evenly distributed over time to help ensure a long life.

APPLICATIONS

- Mains boosting
- Household water supply
- Pressure boosting from above ground water tanks
- Light industrial use

TECHNICAL DATA

Mains voltage

1 x 240 V, 50 Hz

Enclosure class

IP55

Insulation class

F

Sound pressure level

< 55 dB

Approvals and markings

ASNZ4020, CE



CME Booster / CME TWIN Booster

PERFORMANCE

CME Booster

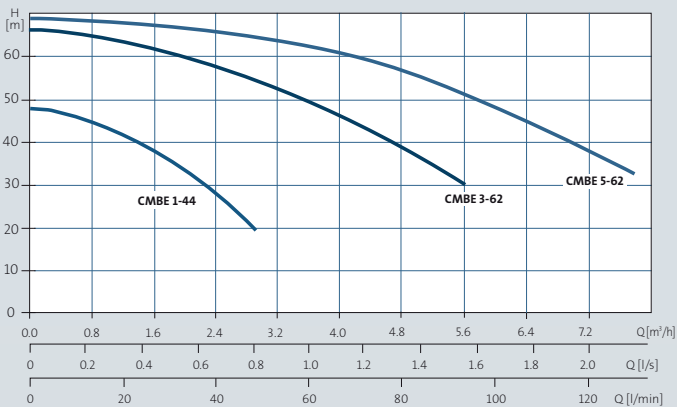

CME TWIN Booster

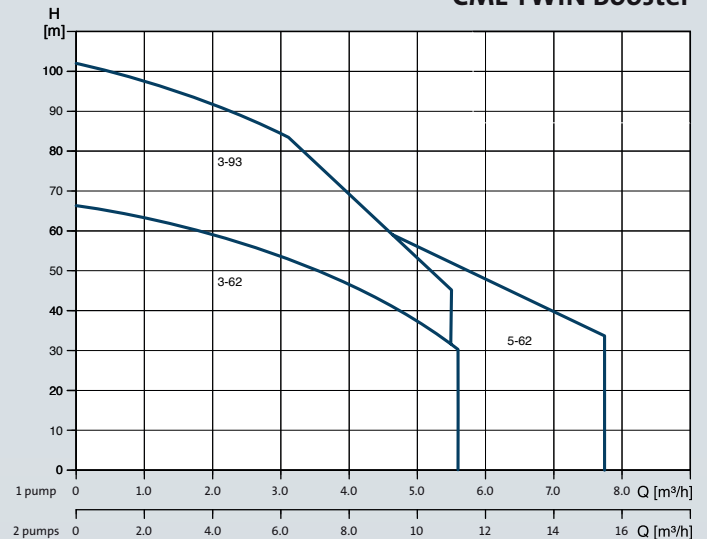

OPERATING CONDITIONS

System pressure

Max. 10 bar

Liquid temperature

0 °C to 60 °C

Ambient temperature

Max. 55 °C

Relative air humidity

Max. 95 %

DIMENSIONS

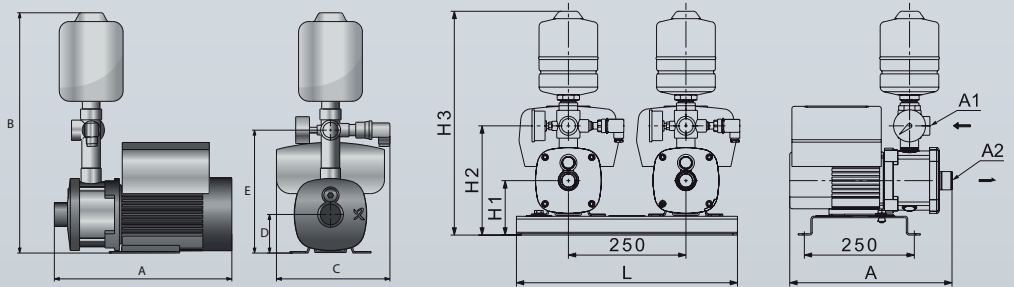

CME Booster

CME TWIN Booster

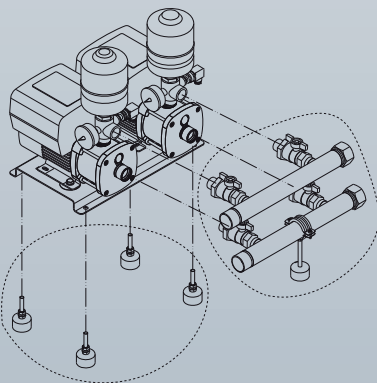

Suction & Discharge Manifold

Model	Power (kW)	Connections		Dimensions (mm)					Weight (kg)
		Outlet	Inlet	A	B	C	D	E	
CMBE 1-44	0.55	1" F	1" F	345	467	221	75	239	16.1
CMBE 3-62	1.1	1" F	1" F	345	467	221	75	239	17.4
CMBE 5-62	1.5	1" F	1¼" F	345	467	221	75	239	18.8

Model	Power (kW)	Connections		Dimensions (mm)					Weight (kg)
		Inlet	Outlet	H3	H2	H1	L	A	
CMBE TWIN 3-62	1.21	1" F	1" F	485	235	110	475	344	40kg
CMBE TWIN 3-93	1.72	1" F	1" F	495	250	125	475	404	44kg
CMBE TWIN 5-62	1.72	1" F	1¼" F	495	250	125	475	350	45kg

Old models		Suitable replacement models
CH-PC	CM Booster	CME Booster
CH2-40 PC	CMB 3-3	CMBE 1-44
CH4-50 PC	CMB 5-5	CMBE 3-62
CH4-60 PC		CMBE 5-62

Please Note: Conversion at 250 kPa