

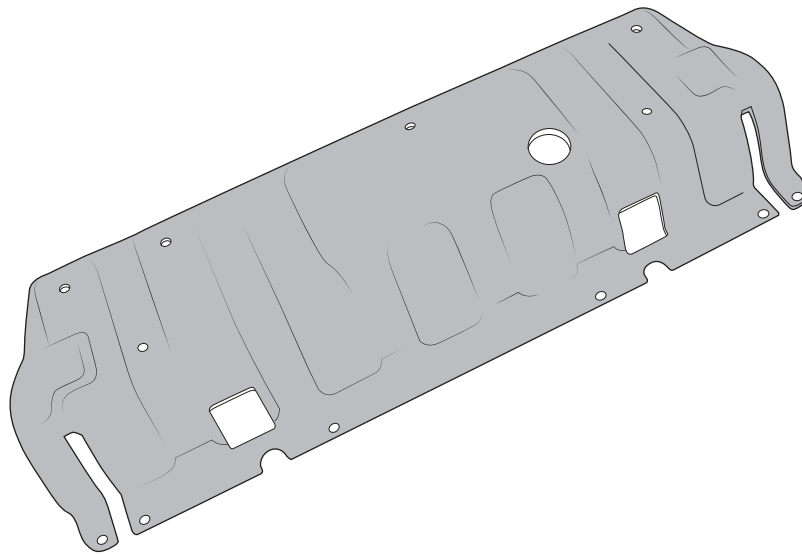

////////////////////////////////////

JK FRONT BUMPER SKID PLATE





PLEASE READ BEFORE YOU START

TO GUARANTEE A QUALITY INSTALLATION, WE RECOMMEND READING THESE INSTRUCTIONS THOROUGHLY BEFORE BEGINNING ANY WORK. THESE INSTRUCTIONS ASSUME A CERTAIN AMOUNT OF MECHANICAL ABILITY AND ARE NOT WRITTEN NOR INTENDED FOR SOMEONE NOT FAMILIAR WITH AUTO REPAIR.

INCLUDED PARTS	QTY	REQUIRED TOOLS
Front Bumper Skid Plate	1	Basic hand tools
Hardware Pack	1	Center Punch
		Drill Motor
		Drill Bits
		De-burring Tool or File
		Touch Up Paint or Rust Inhibitor



INSTALLATION

1. Install the six M8 U-nuts onto the Bumper edge (Fig 1-A) aligning with the six holes in the Bumper.

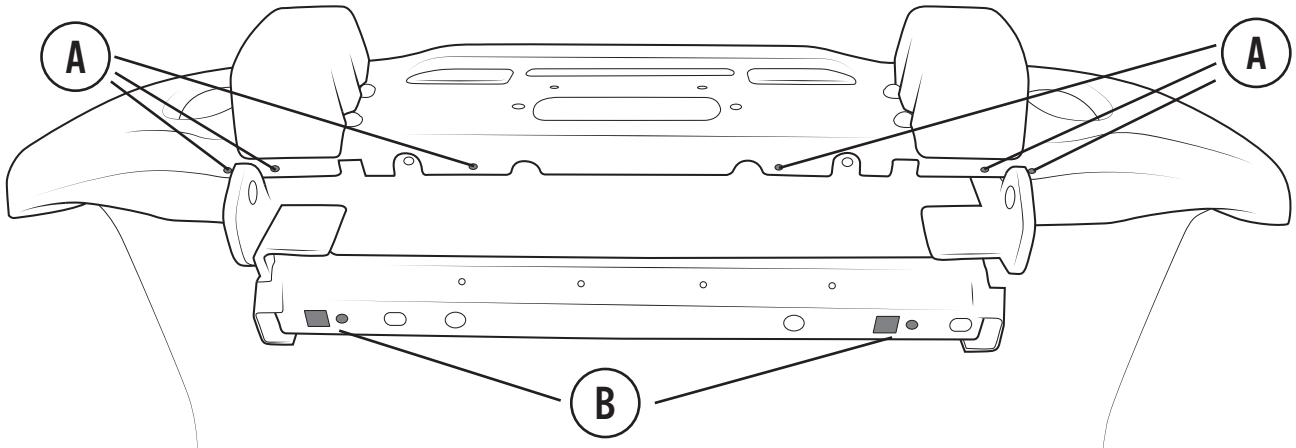

Figure 1

2. Inspect your vehicles compatibility beam (Fig 2). Depending on the model year of your vehicle, your compatibility beam may have the square cut-outs (A), have only the round bolt holes (B), or no attachment holes at all. If NO holes are present skip to step #4.

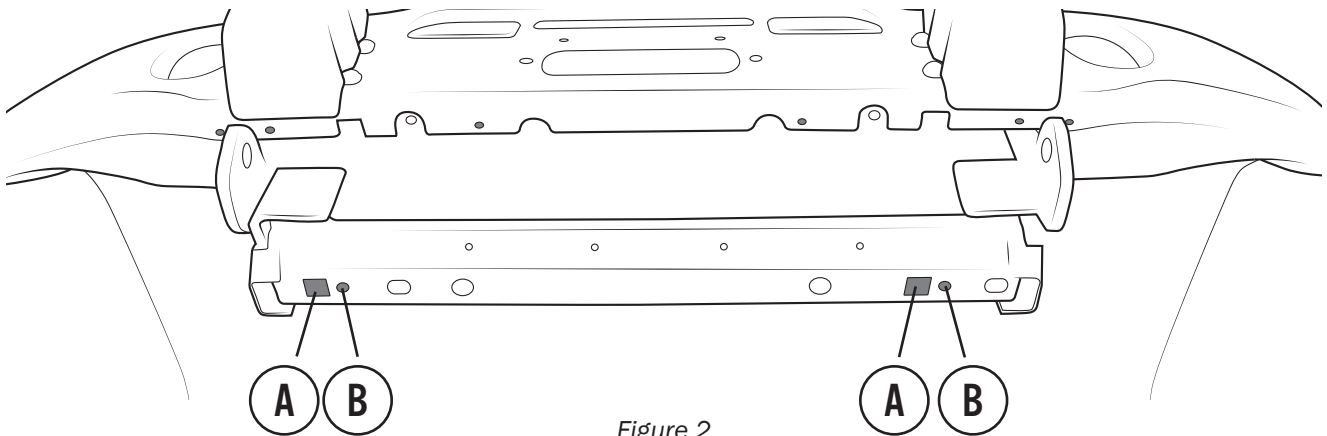
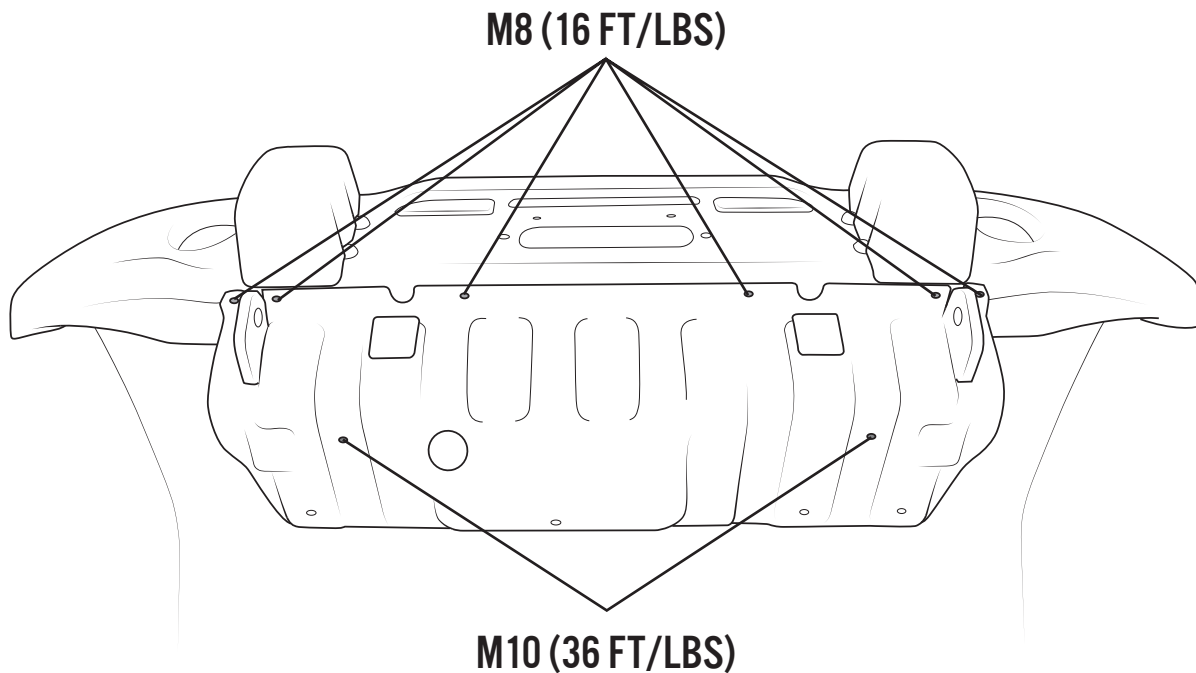

Figure 2

3. Install the two M10 U-nuts into the square cut-outs on the compatibility beam (Fig 1-B), aligning with the adjacent round holes. If the square cut-outs are not present on your vehicle you may skip this step. Continue to step #8.



4. Hold the Skid Plate in position under the Bumper.
5. Using two M8 bolts, attach the Skid Plate to the Front Bumper at the outer-most holes.
6. Hold the rear of the Skid Plate tightly against the compatibility beam, mark the two rear mounting locations and center punch.
7. Remove the Skid Plate and drill two 13mm holes at the locations marked in step 6. De-burr the holes and apply rust inhibitor to all bare edges.
8. Position the Skid Plate for attachment.
9. Install the six M8 washerhead bolts into the Front Bumper. Torque to 16 ft/lbs.
10. Install the two M10 washerhead bolts into the compatibility beam, securing with either the M10 U-nuts (if installed in step 3) or the provided M10 flange nuts. Torque to 36 ft/lbs.



COMMENTS OR QUESTIONS?

American Expedition Vehicles

www.aev-conversions.com

email: tech@aev-conversions.com

ph: 248.926.0256

Be sure to visit our forum at: <http://forum.aev-conversions.com>