

CHS
CHAIN HOIST STORE

CM[®]

LODESTAR[®]
NEXT GENERATION



THE
CHOICE OF
PROFESSIONALS

LODESTAR®

NEXT GENERATION

The Benefits of Superior Design

LESS MAINTENANCE & EASIER INSPECTION

- Heavy Duty DC Brake is designed for a long service life. Brake location allows for quick access and easy inspection.
- Lifetime grease-lubricated Gear Box means no oil change out is required. Precision gears provide better wear and longer life.
- Clutch located outside the Gear Box allows for easy access which eliminates the need for complete disassembly and reduces downtime.

IMPROVED SERVICEABILITY

Easy access to the Clutch, Motor, Electrical Control Panel and Brake Assembly.

LONGER SERVICE LIFE

Lifetime grease-lubricated Gear Box and helical gearing ensures efficient operation. Heavy duty rated motors. Hoist workmanship backed by a lifetime warranty.

QUIETER OPERATION

80% reduction in sound pressure as compared to the classic Lodestar.

IMPROVED LOAD SAFETY

Clutch is located outside the load path which prevents slipping of the load in an overload condition when brake is not powered.

IMPROVED CHAIN LIFE

5 Pocket Lift Wheel provides better chain and lift wheel engagement for smoother lifting and reduced vibration — which equates to less wear and a longer chain life. Zinc plating to protect chain from environmental conditions.

EASY ACCESS CONTROL PANEL

With finger-safe wiring and plug and play connectors, the Control Panel allows for quick voltage change, access to terminal strips and simple fuse installation.

EXCEEDS H4 REQUIREMENTS

Lodestar exceeds H4 requirements, engineered for high duty cycles and the toughest applications.

ECO-FRIENDLY

Lifetime grease-lubricated Gear Box means no changing and disposing of hazardous oil. Documented RoHS compliance. Shipped in boxes made of recycled material.



STANDARD FEATURES

CAPACITIES: 1/8 TO 3 TONS

FABRIC CHAIN CONTAINER & RIGID HOOK SUSPENSION
Standard on every Lodestar

LIFETIME WARRANTY

The industry's best warranty against manufacturing and material defects.

METRIC RATED

CSA/US
National Recognized Testing Laboratory (NRTL)

MADE IN THE USA



OPTIONAL FEATURES

DOUBLE DC BRAKE

Two independent acting DC Brakes for redundant braking. Field Installation Kit available.

AC ELECTRIC BRAKE

VARIABLE SPEED DRIVE (VFD) OR TRADITIONAL 2 SPEEDS AVAILABLE

PRIMARY & SECONDARY TRANSFORMER FUSING

ROTATABLE LIMIT SWITCH

Designed for quick reset of limit position

BLACK PHOSPHATE OR STAINLESS STEEL LOAD CHAIN

METAL & STAINLESS STEEL CHAIN CONTAINERS

INTRODUCING **THE NEXT GENERATION** **OF LODESTAR** **WITH CAPACITIES UP TO 3 TONS**

Columbus McKinnon Corporation, the industry leader in quality lifting and positioning equipment for hoist operators around the globe, presents the new Lodestar.

Lodestar® – iconic in name and legendary in performance – is recognized as the standard in the overhead lifting industry. Generations of users have relied on the Lodestar electric chain hoist for consistent operation throughout its long service life. Now with exciting new features, it's sure to widen its appeal to the next generation of rigging professionals.

Made in the USA, the new Lodestar features quieter operation, an environment friendly design, easier access to key components, higher duty cycles, less maintenance, and enhanced safety features.

Available as individual units, in hoist/trolley combinations, or as integral components of complete lifting systems, the next generation of Lodestar takes lifting to new heights for professionals in any industry.

With a history of unsurpassed performance and over a million units sold, the next generation of Lodestar continues this legacy.

**UNSURPASSED
PERFORMANCE**



Key Components of the Lodestar

MOTOR

Both heavy duty and efficient, the Motor is designed to operate on power supplies worldwide. Standard Class F insulation and thermal motor protection.

HOUSING

Cast aluminum, lightweight housing covered with acid resistant powder coated paint for superior durability and protection against elements. Distinctive CM orange color allows for easy recognition after installation. The sealed drive shaft and standard weather-proofing gasket and seals provide the hoist with a NEMA 3R rating — suitable for outdoor use.

LIFT WHEEL

The Lift Wheel's 5 pockets increase the engagement of the chain and lift wheel to provide smooth lifting with less vibration and reduced chain wear when properly maintained — ultimately extending the life of the chain.

CONTROL PANEL

Easy access to plug & play connectors allow for quick voltage change for dual voltage motors. Effortless fuse installation when required.

CLUTCH

Located outside the gear box for easy access, the Clutch is designed to prevent lifting loads greater than rated capacity.

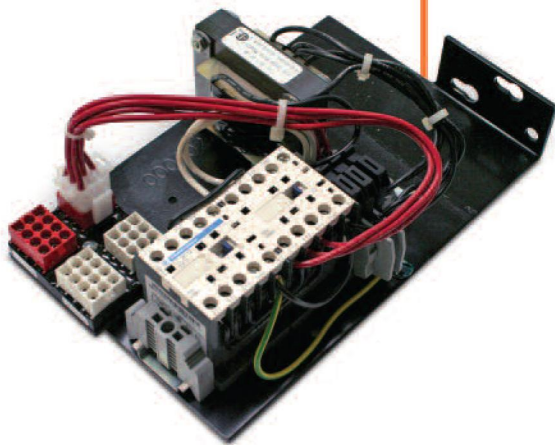

SUSPENSION

Rigid Upper Hook Suspension is standard on every Lodestar. Swivel hook optional. Push, hand-gear, and motorized trolley suspension optional.

GEAR BOX

Precision helical gearing is grease lubricated for quiet, smooth operation, and long service life.

BRAKE

Heavy Duty DC Brake is standard. AC Brake and Double DC Brake are also available.

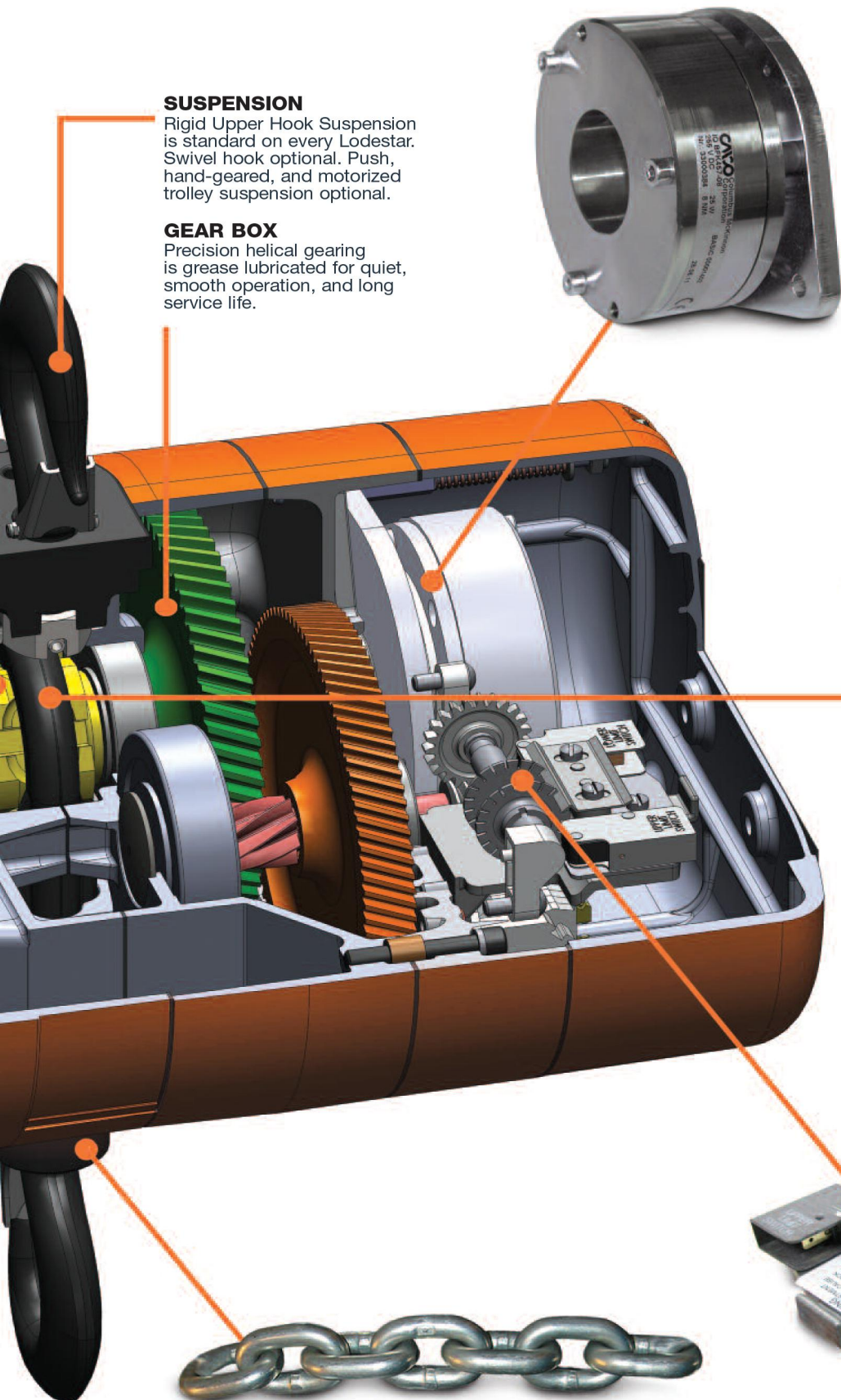

INTERNAL CHAIN GUIDE

The stamped steel Chain Guide, coated for corrosion resistance and quiet operation, keeps the load chain and liftwheel aligned during operation.



LOAD CHAIN & HOOK

Both the Hoistaloy® Load Chain and Forged Steel Hook are manufactured in the USA by Columbus McKinnon. This ensures full compatibility and the highest quality control standards are met at all times. Load Chain is zinc plated for protection against corrosion, and is 100% proof tested.

FABRIC CHAIN CONTAINER

Standard on every Lodestar

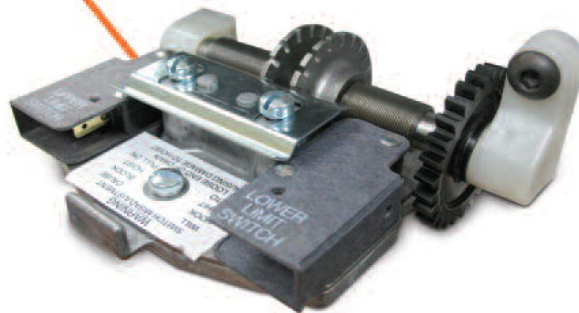

LIMIT SWITCH

Adjustable screw limit switch that automatically stops the hook at any predetermined point when either lifting or lowering. Limits are field-configurable and can be adjusted to the specific application.



LODESTAR[®]

ELECTRIC CHAIN HOIST

2-TON, SINGLE-REEVED

The CM[®] Lodestar[®] is now available as an economical 2-ton, single-reeved unit that's ideal for a variety of industrial lifting applications. And, because it's a single reeved unit, the design prevents the lower hook block from capsizing and damaging the hoist.



BENEFITS & FEATURES

LESS MAINTENANCE & EASIER INSPECTION

- Brake location allows for quick access and easy inspection.
- Lifetime grease-lubricated Gear Box means no oil change is required.
- Clutch located outside the Gear Box allows for easy access which eliminates the need for complete disassembly and reduces downtime.

IMPROVED SERVICEABILITY

Easy access to the Clutch, Motor, Electrical Control Panel and Brake Assembly.

LONGER SERVICE LIFE

- Heavy-duty DC brake is designed for a long service life.
- Lifetime grease-lubricated Gear Box and helical gearing ensures better wear and smooth operation. Heavy-duty rated motors.

IMPROVED LOAD SAFETY

Clutch is located outside the load path preventing slipping of the load in an overload condition when the brake is not powered.

IMPROVED CHAIN LIFE

5-Pocket Lift Wheel provides better chain and lift wheel engagement for smoother lifting and reduced vibration equating to less wear and a longer chain life. Zinc plating protects chain from environmental conditions.

EASY ACCESS CONTROL PANEL

Finger-safe wiring and plug-and-play connectors on the Control Panel allow for quick voltage change, easy access to terminal strips and simple fuse installation.

ZINC PLATED LOAD CHAIN

Designed and manufactured in the USA by Columbus McKinnon. 10 millimeter, zinc plated Star Grade load chain protects against corrosion.

ADJUSTABLE LIMIT SWITCH

Easy-to-adjust screw limit switch automatically stops the hook at any predetermined point when either lifting or lowering, preventing overtravel.

OVERLOAD PROTECTOR

Helps prevent lifting of dangerous overloads.

METRIC RATED

LIFETIME WARRANTY

The industry's best warranty against manufacturing and material defects.

FABRIC CHAIN CONTAINER

Standard up to 20 ft lift.

RIGID HOOK SUSPENSION



CM[®] LODESTAR[®] ELECTRIC CHAIN HOIST

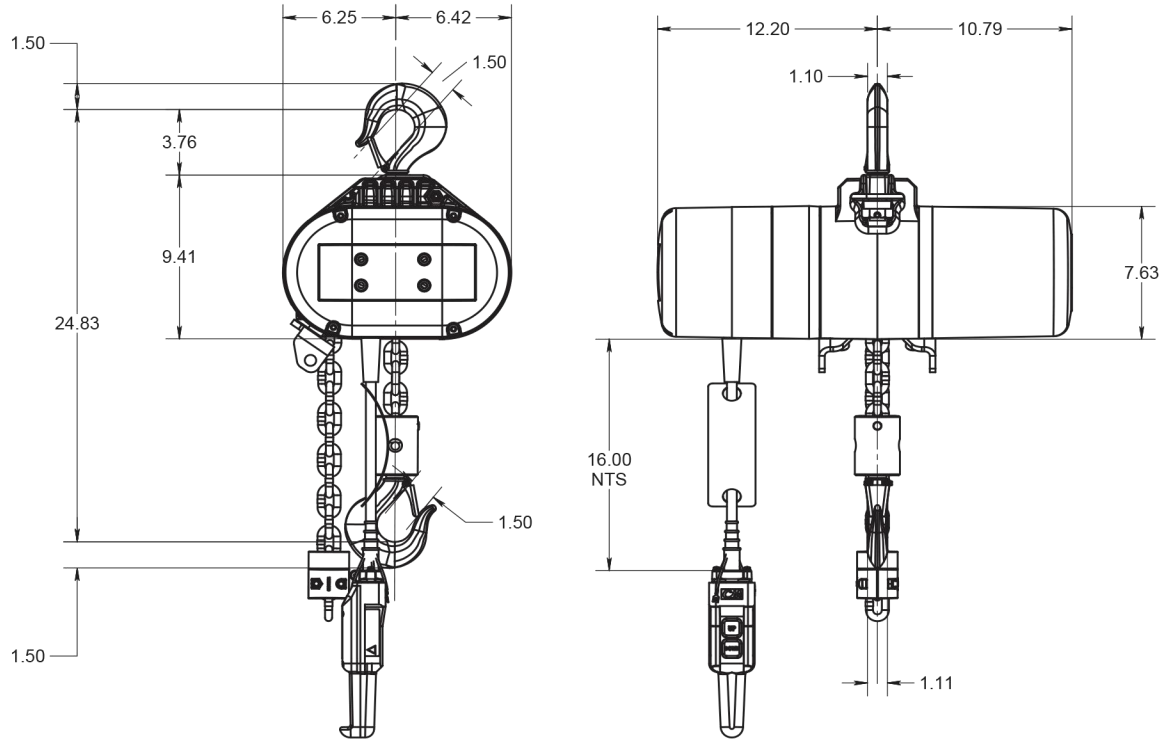

Dimensions (in inches) are RRS model CM Lodestar 2 Ton Single Reeved with Swivel Latch Type Hook Suspension.

OPTIONAL FEATURES

DOUBLE DC BRAKE

Two independent acting DC Brakes for redundant braking. Field installation kit available.

VARIABLE SPEED DRIVE (VFD)

PRIMARY & SECONDARY TRANSFORMER FUSING

DESIGNED FOR QUICK RESET OF LIMIT POSITION.

METAL CHAIN CONTAINERS

CHS

CHAIN HOIST STORE



www.ChainHoistStore.com