

4. STRETCH O-RING OVER STRUT AND INSTALL THREADED TUBE

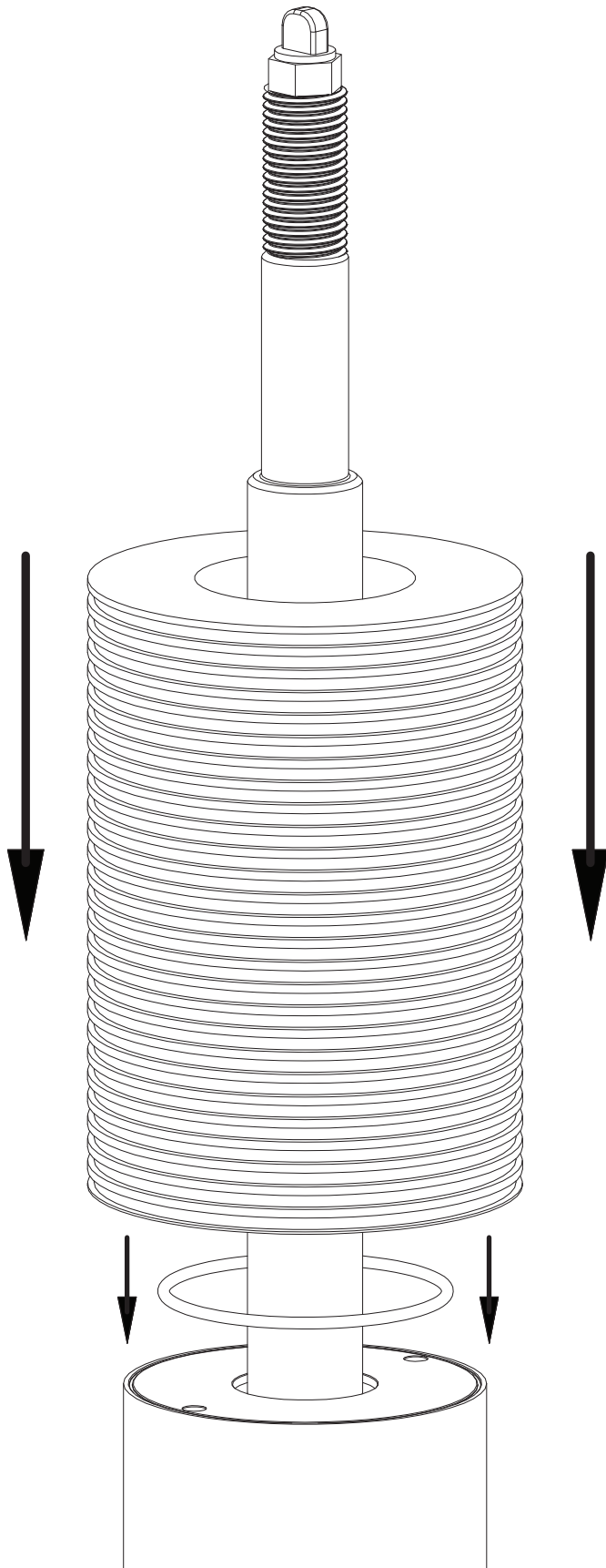

GROUND CONTROL

www.groundcontrolstore.com
3885 Dividend Drive
Shingle Springs, CA 95682
(530)677-8600 fax (530)677-9090

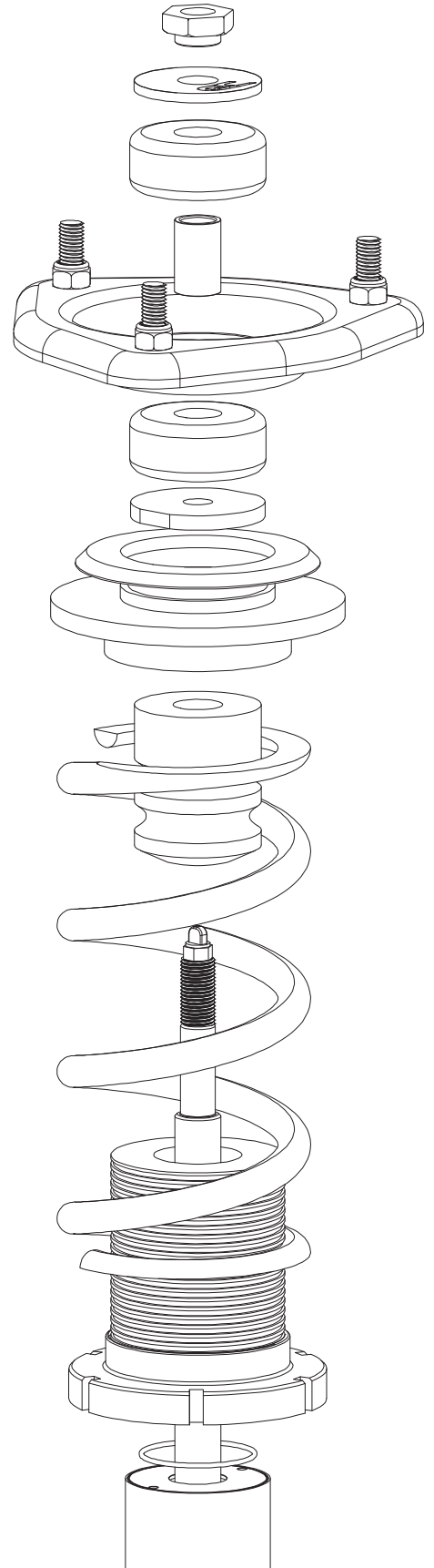

REMOVE OEM SHAFT SPACER BY PLACING SHOCK UPSIDE DOWN IN BENCH VICE. PLACE OPEN END OF 14mm WRENCH ON SPACER AND LIGHTLY TAP WITH HAMMER

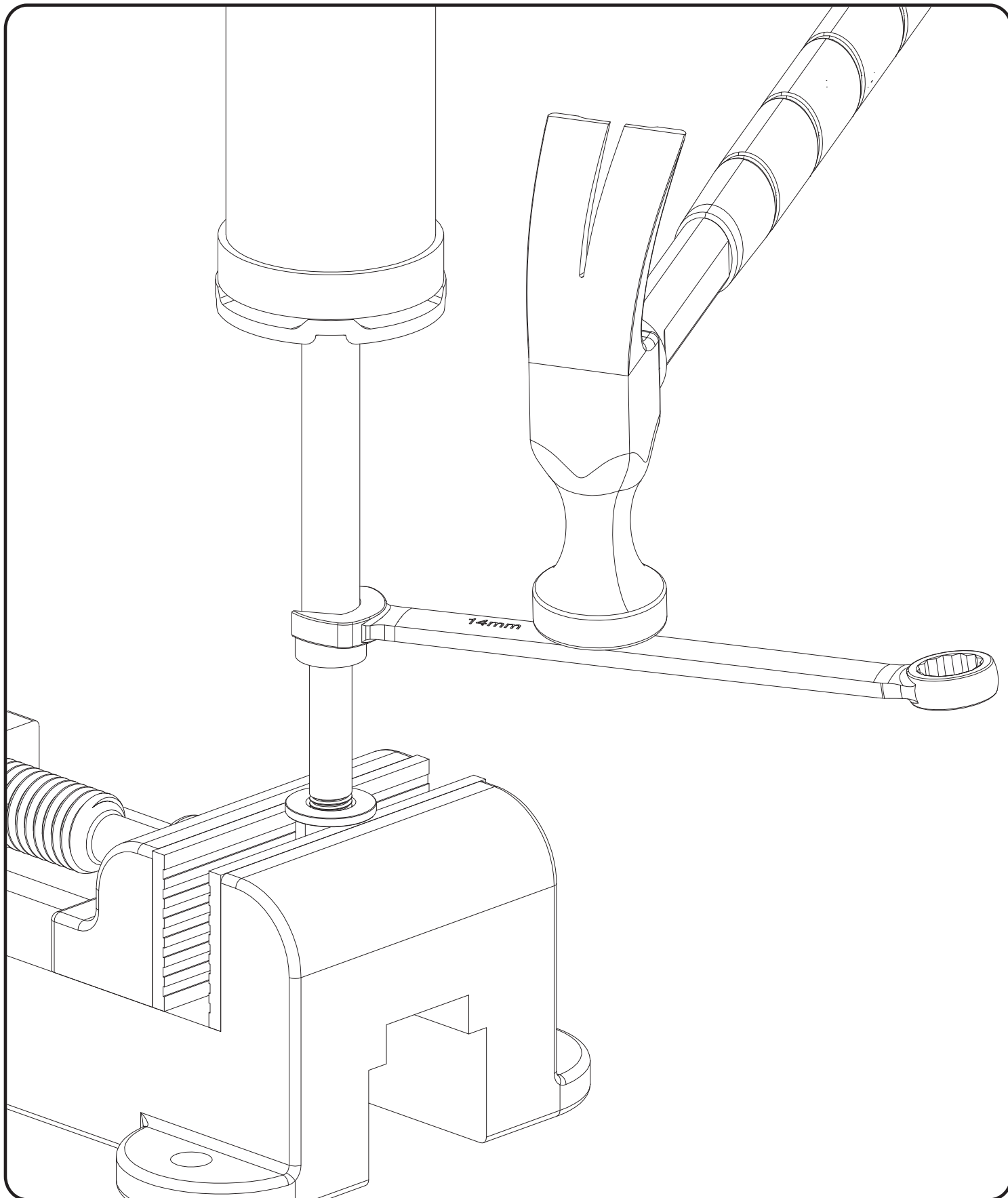

MAZDA ND MIATA FRONT AND REAR COILOVERS - BILSTEIN

1. REMOVE AND DISSASSEMBLE OEM STRUT

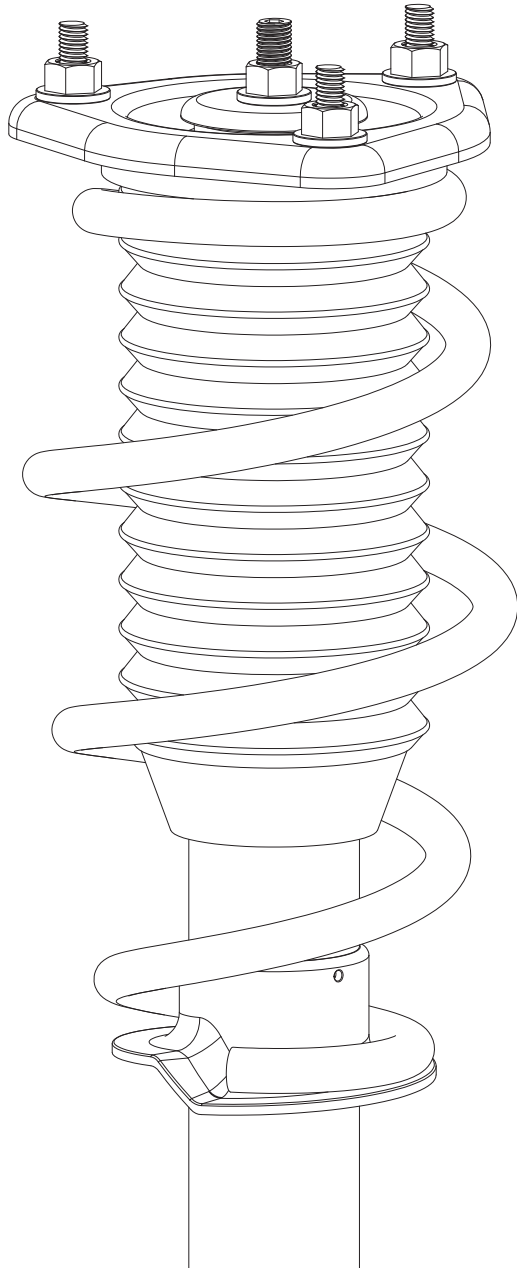

3. REMOVE STOCK SHAFT SPACER AND CAP

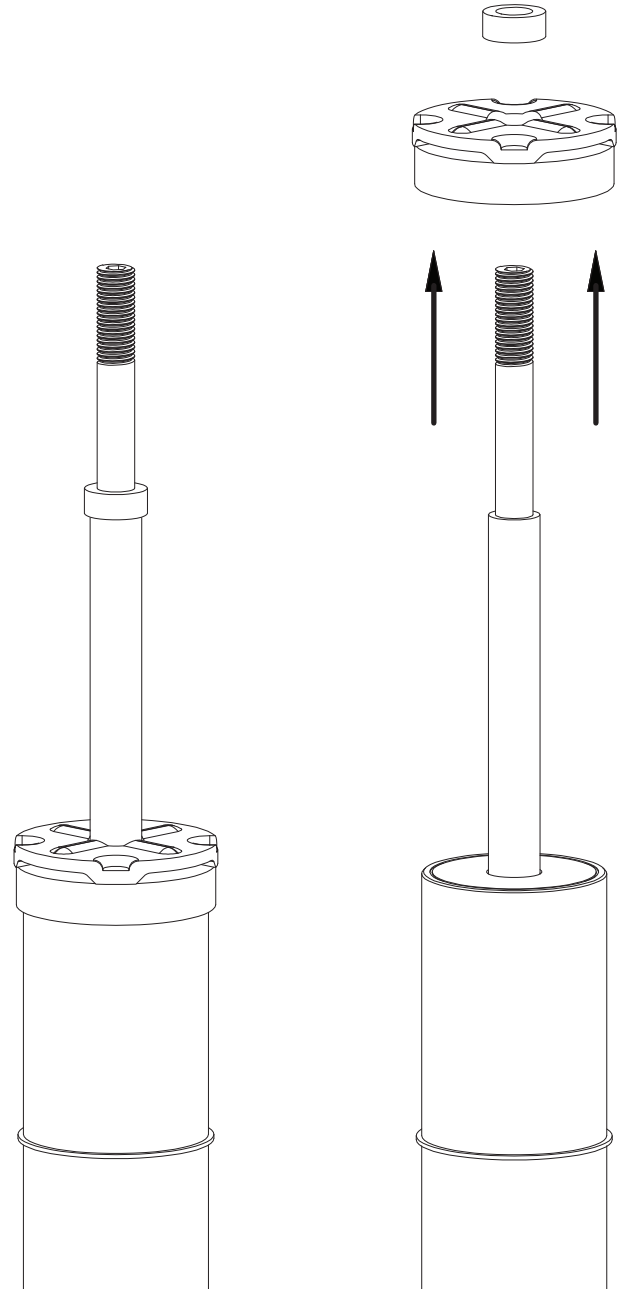

2. CUT BUMP STOP 1.5 INCHES FROM TOP AND DISCARD LOWER SECTION

USE THIS SECTION

