

E36 RACE CAMBER PLATE INSTRUCTIONS

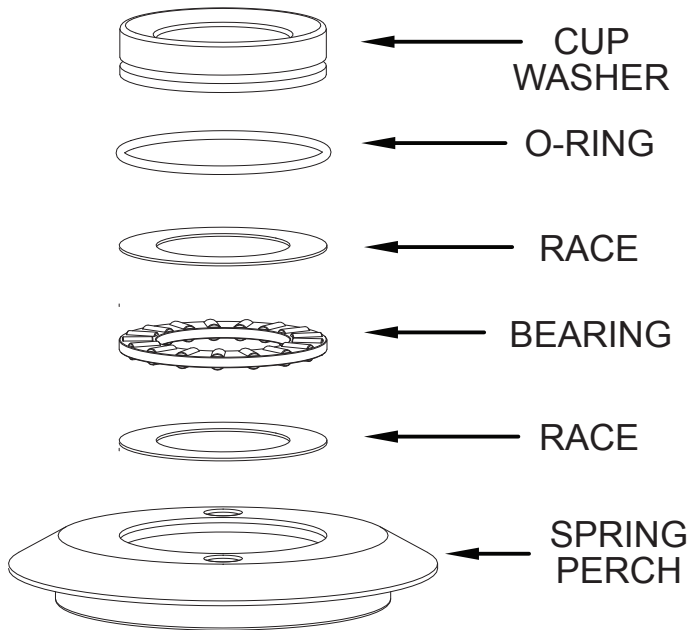

- CLEAN AND DISASSEMBLE ALL COMPONENTS IN SPRING PERCH
- GREASE BEARING USING HIGH TEMP MARINE GREASE
- ENSURE GREASE FILLS HOUSING OF BEARING
- CLEAN O-RING SEATS
- LUBRICATE O-RING AND RE-INSTALL INTO CUP WASHER
- INSTALL COMPONENTS INTO SPRING PERCH
- LUBRICATE TOP SURFACE OF CUP WASHER

TWO BOLTS ARE USED ON THE SIDE NEAREST TO THE FRONT OF THE CAR

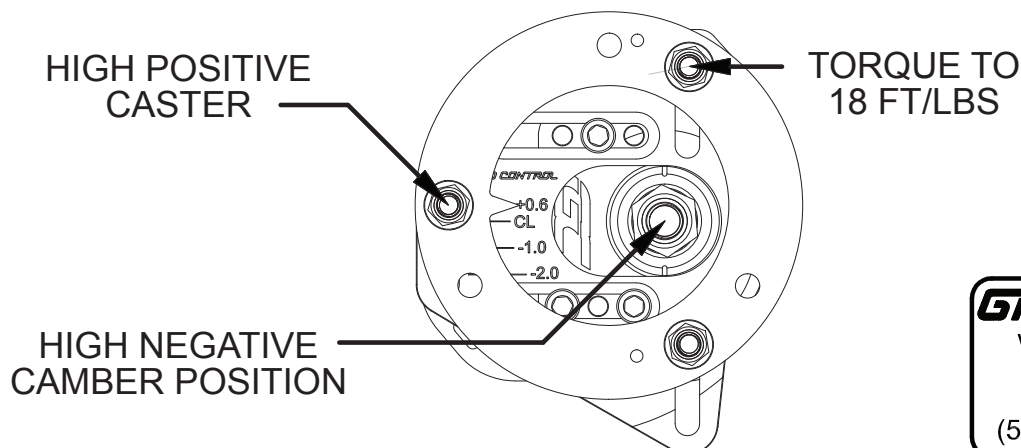
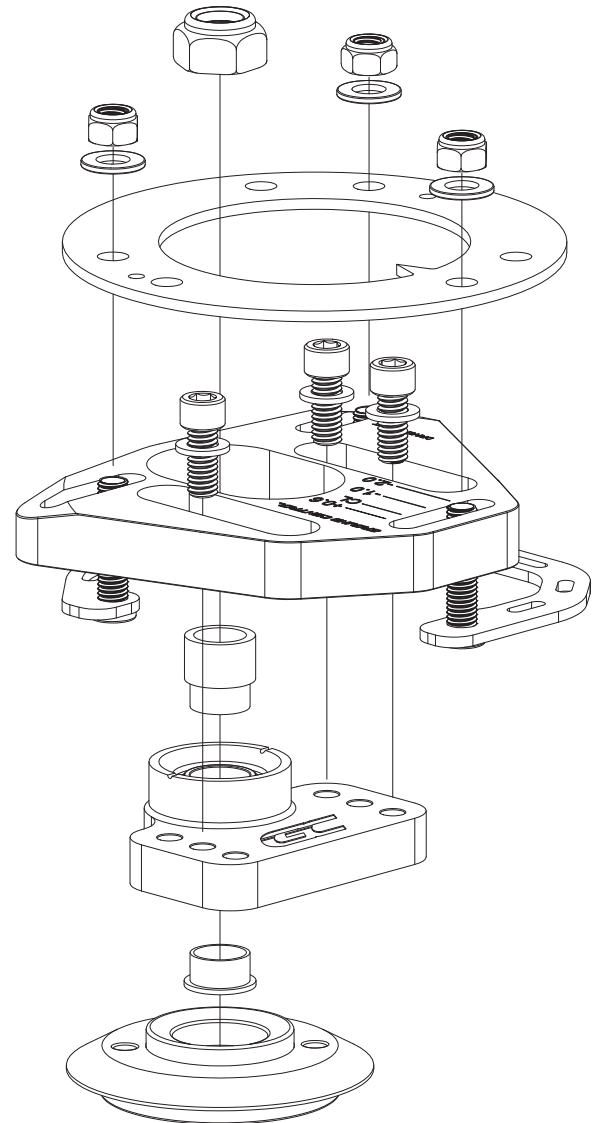

GROUND CONTROL

www.groundcontrolstore.com
3885 Dividend Drive
Shingle Springs, CA 95682
(530)677-8600 fax (530)677-9090