

BMW SPEC E30 COILOVERS WITHOUT GROUND CONTROL CAMBER PLATES

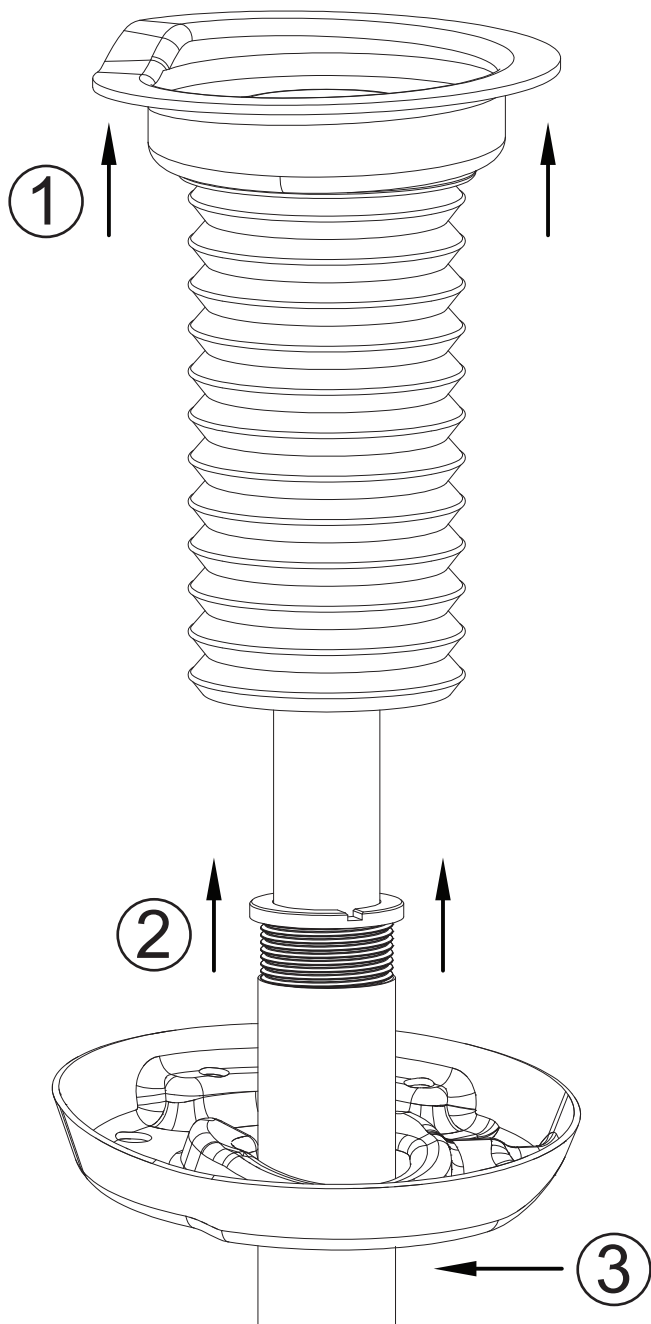

- 1 REMOVE OEM TOP HAT
- 2 REMOVE OEM GLAND NUT FROM STRUT
- 3 CUT ABOVE WELD TO REMOVE SPRING PERCH

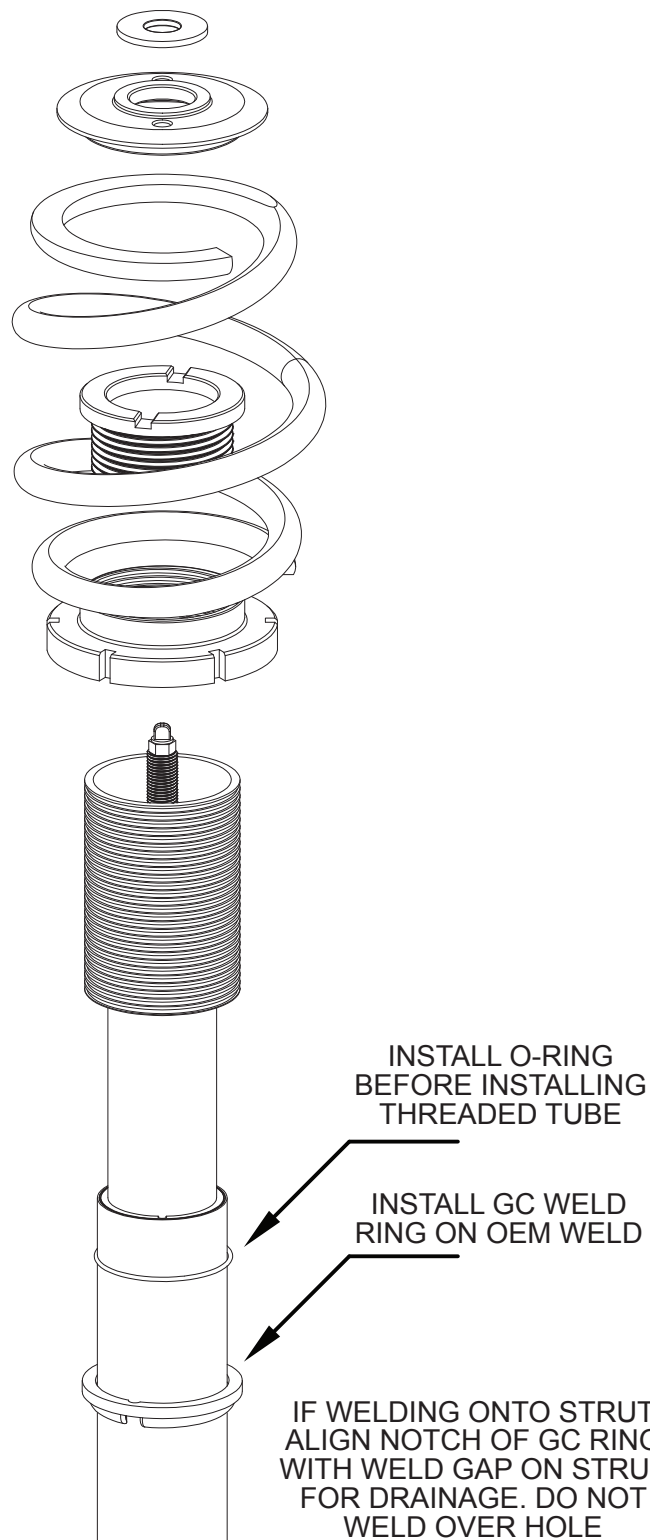

GROUND CONTROL

www.groundcontrolstore.com
3885 Dividend Drive
Shingle Springs, CA 95682
(530)677-8600 fax (530)677-9090