

# TERRATEK

## 18V Lithium Cordless Drill TD18 User Manual

Please read and  
retain for future  
reference



[www.futura-direct.co.uk](http://www.futura-direct.co.uk)

Search for  
*futura* *direct*

on You 

For in-depth  
user guides &  
tutorials

Follow Us @:



# TERRATEK 18V Lithium Cordless Drill TD18

Thank you for purchasing our 18V Cordless Drill which has been designed to give many years of service under normal use. In order to get the most from your 18V Cordless Drill please carefully read and follow the instruction provided.

## CONTENTS

- Parts List**
- Technical Information**
- Safety Instructions**
- Using your drill**
- Maintenance**
- Warranty**

## PART LIST

<b>No</b>	<b>Description</b>	<b>No.</b>	<b>Description</b>
1	Anti-Screw	18	Sun Gear
2	Chuck	19	1 <sup>st</sup> Planet Gear
3	Clutch Cap	20	Motor Gear
4	Clutch Cap	21	Washer
5	Adjust Nut	22	Screw
6	Spring	23	Washer
7	Washer	24	Motor Plate
8	Steel Ball	25	Motor
9	Circlip	26	Screw
10	Steel Ball	27	Right Housing
11	Washer	28	Leaf Spring
12	Gear Box	29	Gauge Cover
13	Pin	30	F/R Lever
14	Output Shaft	31	Switch
15	Bush	32	PCB Board
16	Ring Gear	33	Left Housing
17	2 <sup>nd</sup> Planet Gear	34	Battery

# TERRATEK 18V Lithium Cordless Drill TD18

## Exploded Assembly Diagram

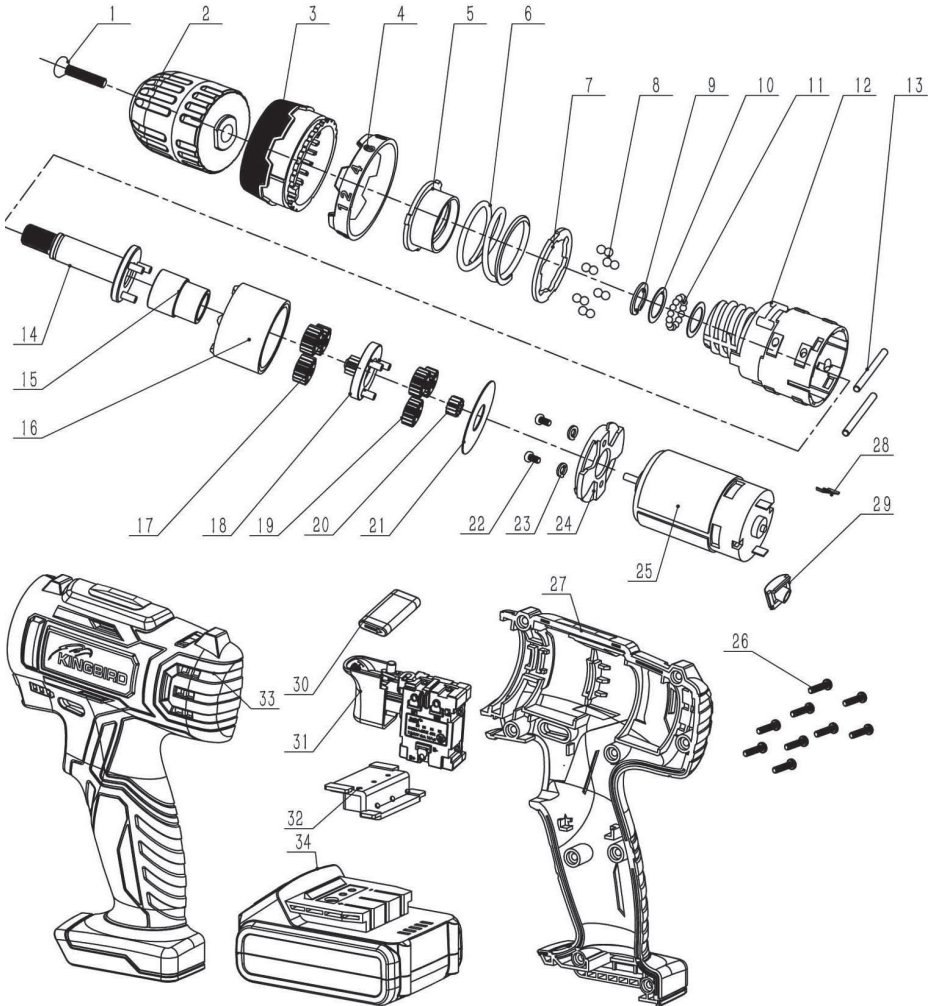

NOTICE: Actual product may vary from pictures shown.

# TERRATEK 18V Lithium Cordless Drill TD18

## Overview:



Fig. 1

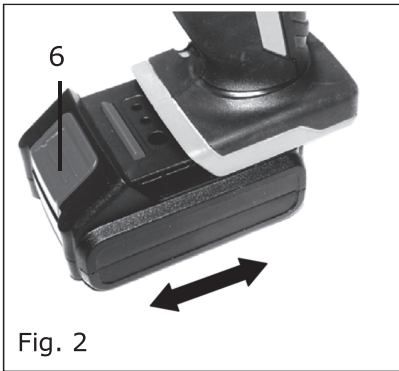

Fig. 2

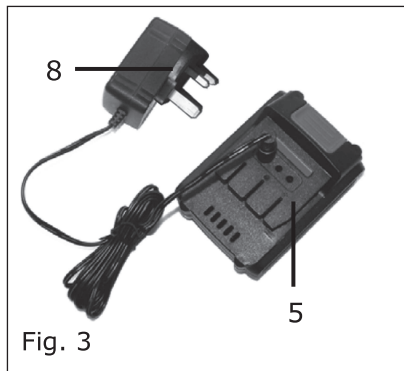

Fig. 3

# TERRATEK 18V Lithium Cordless Drill TD18

## Specification: (Fig.1)

1. Chuck
2. Torque control ring
3. Forward/Reverse/Lockout
4. On/Off/Variable speed switch
5. Battery
6. Battery Clip
7. LED lamp
8. Charger

## TECHNICAL INFORMATION

### 18 V Cordless Drill

#### Model: TD18

Battery voltage: 18 V

Chuck capacity: 0.8 – 10 mm

Max drilling capacity (steel) 8 mm

Max drilling capacity (wood) 20 mm

No load speed: 0 – 650 /min

Torque settings 16 plus drill setting



Protection class III

### Battery charger

#### Model: GT07W220026B

Input: 100-240V AC/ 50-60Hz 12 W

Output: 22V DC/ 260 mA



Protection category II

### Lithium Battery

Battery model: ZFUT01BAT-3

Capacity: 800 mAh

### Noise and vibration levels

Sound pressure level 79.0 dB(A);

# TERRATEK 18V Lithium Cordless Drill TD18

Sound power level 90.0 dB(A)

Uncertainty KPA: 3.0 dB(A) and KwA:3.0 dB(A)

**Ear protection is required for the user.**

## Vibration levels

Drilling into metal:  $a_{hD} = 1.339 \text{ m/s}^2$ , uncertainty  $K_D = 1.5 \text{ m/s}^2$

The declared vibration total has been measured in accordance with a standard test method and may be used for comparing one tool with another. This total may also be used in a preliminary assessment of exposure.



**Read this entire manual before using this product. Failure to do so can result in serious injury. Save this manual for future reference.**

Copyright© 2017 by FUTURA Direct Ltd. All rights reserved. This manual or any artwork contained herein must not be reproduced in any shape or form without the express written consent of FUTURA Direct Ltd. Diagrams within this manual may not be drawn proportionally. Due to continuing improvements, actual product may differ slightly from the product described herein.

## SAFETY INSTRUCTIONS

### Read and Keep the Manual

Please read carefully all instructions within this manual. Failure to follow all safety warnings can result in serious personal injury. The term "Power Tool" in all of the following warnings refers to your mains operated (corded) or battery operated (cordless) power tool

### Important SAFETY Information



**This symbol is to warn you of potential personal injury hazards. Please read carefully the notes alongside this warning to avoid possible injury or death.**

### General Safety Rules



**WARNING!** Read all instructions. Failure to follow all instructions listed below may result in electric shock, fire and/or serious injury. The term "power tool" in all of the warnings listed refers to corded or cordless power tools.

### Work area safety

Keep work area clean and well lit. ***Cluttered or dark areas invite accidents.***

Do not operate power tools in explosive atmospheres, such as in the presence of flammable

# TERRATEK

## 18V Lithium Cordless Drill TD18

liquids, gases or dust. *Power tools create sparks which may ignite the dust or fumes.*

Keep children and bystanders away while operating a power tool. *Distractions can cause you to lose control.*

### **Electrical safety**

Before use, ensure that the power outlet you are using matches the plug on your power tool and that the voltage of the outlet matches that of your power tool.

Only use grounded extension cords with power tools fitted with proper plugs and if using outdoors ensure any extension cord is suitable for outdoor use.

Always try to avoid body contact with grounded surfaces, such as radiators, cooking ranges and any other fixed appliance with metal surfaces.

Do not expose your power tool to wet or damp conditions and NEVER use in rain.

Check the power cord of your machine regularly and any extension cord that you are using for damage.

Do not carry or pull the machine with the power cord.

Ensure the cord is clear from hot surfaces, oil or sharp objects.

### **Personal safety**

Never use your power tool whilst under the influence of alcohol, drugs or medication.

Tiredness can often cause accidents, stay alert.

Never use your power tool without the correct guards in place.

Always use approved eye protection and dust mask. Non slip safety shoes and hearing protectors should be worn at all times when using your power tool.

Ensure any dust collecting device supplied with your power tool is connected correctly before use.

Ensure all loose clothing, long hair or jewelry is kept clear of the power tool.

Before plugging your power tool into the power outlet ensure the power tool is in the OFF position.

Check that wrenches or adjusting keys have been removed. Any wrench or key left attached to a moving part can result in injury.

### **Power tool use and care**

Keep your power tool clean and well serviced at all times.

Never adjust or service any power tool before disconnecting from the mains electricity supply.

Always use the correct tool for the job.

Never force the tool to work harder than it is designed to do.

Never use your power tool with broken parts such as switches, guide fences or leg stands.

ALWAYS keep your power tools away from children.

Keep cutting tools sharp to ensure less stress on the motor.

Only have your power tool serviced by a qualified repair agent using manufacturers recommended parts.



# TERRATEK 18V Lithium Cordless Drill TD18

**WARNING:** For your own safety read Instruction Manual before operating your tool.

- A) Wear eye protection.
- B) Keep hands away from drill bit.
- C) Do not operate without guards in place.
- D) Do not perform any operation freehand.
- E) Never grab chuck while it is turning.
- F) Turn off tool and wait for tool to stop before moving workpiece or changing settings.
- G) Remove battery before changing drill bit or servicing.

**Read this owner's manual completely and make sure you understand all of its safety guidelines.**

- 1) Do not overload the appliance. Use the correct tool for your work. You will be able to work better and more safely within the given performance boundaries.
- 2) Do not use an electric tool with a defective switch. An electric tool that cannot be switched on or off is dangerous and must be repaired.
- 3) Pull the plug out of the socket and/or remove the battery before making any adjustments to the appliance, changing accessories or put the appliance down. This safety measure prevents starting the electric tool unintentionally.
- 4) Keep unused electric tools out of the reach of children. Do not allow people who are not familiar with the appliance or who have not read these instructions to use the appliance. Electric tools are dangerous if they are used by inexperienced people.
- 5) Clean your electric tool carefully. Check whether moving parts are functioning properly and not jamming, whether parts are broken or damaged enough that the function of this electric tool is affected. Have damaged parts repaired before using the appliance. Many accidents are caused by badly maintained electric tools.
- 6) Keep your cutting tools sharp and clean. Carefully maintained cutting tools with sharp cutting edges will jam less and are easier to control.
- 7) Make sure to use electric tools, accessories, attachments, etc. in accordance with these instructions. Take the conditions in your work area and the job in hand into account. Using electric tools for any purpose other than the one for which they are intended can lead to dangerous situations.
- 8) Ensure that the tool is switched off before you insert the battery. Inserting a battery into an electric tool that is switched on can cause accidents.
- 9) Only charge the batteries in chargers that are recommended by the manufacturer. A charger that is designed for a certain type of battery may pose a fire risk if it is used with other types of battery.
- 10) Use only the correct batteries in the electric tools. The use of other batteries may result in injuries and a fire risk.
- 11) Keep unused batteries away from paper clips, coins, keys, nails, screws and other metallic objects that could cause a short circuit between the contacts. A short circuit between the battery contacts may cause burns or a fire.

# TERRATEK

## 18V Lithium Cordless Drill TD18

12) In case of incorrect use, fluid may escape from the battery. Avoid contact with it. If you touch it by accident, rinse the affected area with water. If you get the fluid in your eyes, also seek medical advice. Leaking battery fluid can cause skin irritation or burns.

### **Safety Warnings for Battery Pack**

- a) Do not dismantle, open or shred cells or battery pack.
- b) Do not short-circuit a battery pack. Do not store battery packs haphazardly in a box or drawer where they may short-circuit each other or be short-circuited by conductive materials. When battery pack is not in use, keep it away from other metal objects, like paper clips, coins, keys, nails, screws or other small metal objects that can make a connection from one terminal to another. Shorting the battery terminals together may cause burns or a fire.
- c) Do not expose battery pack to heat or fire. Avoid storage in direct sunlight.
- d) Do not subject battery pack to mechanical shock.
- e) In the event of battery leaking, do not allow the liquid to come into contact with the skin or eyes. If contact has been made, wash the affected area with copious amounts of water and seek medical advice.
- f) Seek medical advice immediately if a cell or battery pack has been swallowed.
- g) Keep battery pack clean and dry.
- h) Wipe the battery pack terminals with a clean dry cloth if they become dirty.
- i) Battery pack needs to be charged before use. Always refer to this instruction and use the correct charging procedure.
- j) Do not leave battery pack on charge when not in use.
- k) After extended periods of storage, it may be necessary to charge and discharge the battery pack several times to obtain maximum performance.
- l) Battery pack gives its best performance when it is operated at normal room temperature ( $20\text{ }^{\circ}\text{C} \pm 5\text{ }^{\circ}\text{C}$ ).
- m) When disposing of battery packs, keep battery packs of different electrochemical systems separate from each other.
- n) Recharge only with the charger specified. Do not use any charger other than that specifically provided for use with the equipment. A charger that is suitable for one type of battery pack may create a risk of fire when used with another battery pack.
- o) Do not use any battery pack which is not designed for use with the equipment.
- p) Keep battery pack out of the reach of children.
- q) Retain the original product literature for future reference.
- r) Remove the battery from the equipment when not in use.
- s) Dispose of properly.

### **Additional Safety Instructions for Your Battery Charger**

- 1. Do not charge a leaking battery.
- 2. Do not use chargers for tools other than those for which they are designed.
- 3. Before charging, ensure your charger is matches the local AC supply.
- 4. For indoor use, do not expose to rain.
- 5. The charging device must be protected from moisture.

# TERRATEK 18V Lithium Cordless Drill TD18

6. Do not short out the contacts of battery or charger.
7. Do not open the unit and keep out of the reach of children.
8. Do not charge the batteries of other manufacturers or ill-suited models.
9. Ensure that the connection between the battery charger and battery is correctly positioned and is not obstructed by foreign bodies.
10. Keep battery charger's slots free of foreign objects and protect against dirt and humidity. Store the unit in a dry and frost-free place.
11. When charging batteries, ensure that the battery charger is in a well-ventilated area and away from flammable materials. Batteries can get hot during charging. Do not overcharge any batteries. Ensure that batteries and chargers are not left unsupervised during charging.
12. Do not recharge non-rechargeable batteries, as they can overheat and break.
13. Longer life and better performance can be obtained if the battery pack is charged when the air temperature is between 18°C and 24°C. Do not charge the battery pack in air temperatures below 4.5°C, or above 40.5°C. This is important as it can prevent serious damage to the battery pack.
14. Charge only battery packs of the same model provided.

## Power Extension Cords

When using any extension cord the machine will suffer a power reduction due to the drop in voltage caused by the length of the cord. This can be partially offset by selecting extension cords with lower gauge wire.

Check all extension cords for damage before use.  
Avoid sharp objects.  
Do not position the cord where it could be subject to traffic passing over it.

## Symbols

**IMPORTANT:** Some of the following symbols may be used on your tool.

- V.....volts
- A.....amperes
- Hz.....hertz
- ~ .....alternating current
- .../m.....revolutions per minute
-  .....class II construction (double insulated)
- Kg.....kilograms
- n<sub>0</sub>.....No load speed
- CE .....Conforms to European safety standards
- DC .....Direct Current

## Unpacking

Carefully remove the product and any accessories from the box. Make sure that all items listed in the packing list are included.

# TERRATEK 18V Lithium Cordless Drill TD18

## Packing List

- A) Drill
- B) Battery
- C) Charger
- D) Manual

## Charging the Battery Pack (Fig. 2 and 3)

1. Before first use, the battery (5) must be loaded.
2. Only use the provided charging unit (8) to charge the battery.
3. Only charge the battery when the ambient temperature is within 10° - 40° C.
4. Plug the adaptor (8) to a 230V alternating voltage source.
5. The battery (5) should under no circumstances be disassembled.
6. To remove the battery, press the attachment clip (6) on the top side of the battery and extract the battery (5).
7. Connect the plug of the charger to the loading-socket of the battery.
8. Red and green LED will light once the battery has been connected to the charger and the charging procedure will proceed.
9. The battery is fully charged and ready for use once the green LED is lit and the red LED is OFF.

## USING YOUR DRILL

### Keyless chuck

The keyless drill chuck (1) allows the clamping of drill bits or other tools without the use of a drill chuck key.

1. Before inserting a drill bit or other tool, the rotation direction switch (3) must be switched to its central position.
2. Rotate the front section of the drill chuck (1) to the right to open the jaws until the tool can be inserted.
3. Insert the drill bit or the tool as far as it will go into the drill chuck.
4. To close the drill chuck, rotate the front section to the left to close the jaws.
5. Ensure that the drill bit or tool is seated correctly and centrally as you close the drill chuck.

**NOTE:** If the chuck becomes loose during operation, tighten it further.  
The tightening force becomes stronger when the sleeve is tightened.

### Working LED lamp

Pushing the On/Off Switch button (4) will turn on the working LED lamp (7).  
Releasing the On/Off Switch button (4) will switch off the working LED lamp (7).

### Variable Speed Controlled Trigger Switch

Your tool is equipped with a variable speed trigger switch. The tool speed can be controlled from the minimum to the maximum RPM by the pressure you apply to the trigger.

# TERRATEK 18V Lithium Cordless Drill TD18

Apply more pressure to increase the speed and release pressure to decrease speed.

## Forward/Reversing Lever & Trigger Lock

Your tool is equipped with a forward/ reversing lever and trigger lock located above the trigger. This lever was designed for changing rotation of the chuck, and for locking the trigger in an "OFF" position to help prevent accidental starts and accidental battery discharge. For forward rotation, (with chuck pointed away from you) move the lever to the far left. For reverse rotation move the lever to the far right.

To activate trigger lock move lever to the center "off" position.

**CAUTION: Ensure the drill has come to a complete stop before changing direction.**

## Drilling

Place the bit on the work surface and apply firm pressure before starting. Too much pressure will slow the bit and reduce drilling efficiency. Too little pressure will cause the bit to slide over the work area and dull the point of the bit. If the tool begins to stall, reduce pressure slightly to allow the bit to regain speed. If the bit binds, reverse the motor to free the bit from the workpiece.

## Drilling in wood

1. Make an indentation at the desired hole location using a centre punch or nail.
2. Place a piece of waste wood under the workpiece or drill the hole from both sides to avoid damaging the workpiece at hole breakthrough.

## Driving wood screws

1. Where possible use crosshead wood screws.
2. Ensure that you use the correctly sized screwdriver bit.
3. Drill an appropriately sized pilot hole before driving in the screw. Driving without pilot holes increases the risk that the wood may split or that the screw may break.

## Drilling in metal

1. Make an indentation at the desired location using a centre punch.
2. Always secure the workpiece using an appropriate clamping device. Lay a piece of wood under thin sheets of metal to prevent deformation.
3. Use only well sharpened HSS drill bits when drilling metal. If a large hole diameter is required, drill a pilot hole using a smaller bit first.
4. When drilling metal, consult the following table to determine the appropriate lubricant.

Material	Lubricant
Steel	Oil
Aluminium	Turpentine or paraffin
Brass, copper, cast iron	No lubricant (remove the drill from the hole regularly to aid cooling)

# TERRATEK 18V Lithium Cordless Drill TD18

## Torque Adjustment

By turning the adjustment ring (Fig.1) the required torque can be adjusted. The arrow aligns with the adjusted state.

## CARE AND MAINTENANCE

### Before cleaning

Always pull out the mains power plug before starting any cleaning work.

There are no parts inside the equipment which require additional maintenance.

### Cleaning

1. Keep all safety devices, air vents and the motor housing free of dirt and dust as far as possible. Wipe the equipment with a clean cloth or blow it with compressed air at low pressure.
2. We recommend that you clean the device immediately each time you have finished using it.
3. Clean the equipment regularly with a moist cloth and some soft soap. Do not use cleaning agents or solvents; these could attack the plastic parts of the equipment. Ensure that no water can seep into the device. The ingress of water into an electric tool increases the risk of an electric shock.

### Disposal of the exhausted battery

**WARNING:** Do not dispose of the exhausted battery. The battery can explode if it is incinerated. The product that you have purchased contains a rechargeable battery. The battery is recyclable. At the end of its useful life, under various state and local laws, it may be illegal to dispose of this battery into the municipal waste stream. Check with your local solid waste officials for details in your area for recycling options or proper disposal.

### Disposal

Power tools, accessories and packaging should be sorted for environmentally-friendly recycling.

#### Only for EC countries:



Do not dispose of power tools into household waste!

According to the European Directive 2002/96/EC on waste electrical and electronic equipment and its incorporation into national right, products that are no longer suitable for use must be separately collected and sent for recovery in an

environmentally-friendly manner.

## DECLARATION OF CONFORMITY

The declaration is to certify that it conforms to CE, EMC, MD and RoHS directives:  
EN55014-1:2006+A1 + A2  
EN55014-2:2015

All provisions of Annex 1 of Council Directive 2014/30/EU – EMC directive  
EN60745-1: 2009 + A11  
EN60745-2-1: 2010  
EN60745-2-2: 2010

All provisions of Annex 1 of Council Directive 2006/42/EC – the Machinery Directive  
RoHS 2011/65/EU



Mr. Paul Kaye, UK QA Manager  
Please read the following carefully  
FUTURA Direct Ltd. and/or its distributor have  
provided the parts list and assembly diagram as  
a reference tool only.

Neither FUTURA Direct Ltd. or its distributor makes any representation or warranty of any kind to the buyer that he or she is qualified to do any repairs or replace any parts of this product. FUTURA Direct Ltd. and its distributor expressly state that all repairs or parts replacement should be done by certified or licensed technicians. The buyer assumes all risk and liability arising out of his or her repairs or parts replacement to the original product.

## 24 MONTHS LIMITED WARRANTY

If within 24 months from the date of purchase you experience any problems with your product, please return the product to its distributor/dealer for repair or replacement. This warranty DOES NOT COVER normal wear, or any damage as a result of accidents, misuse, abuse or negligence.

[www.futura direct.co.uk](http://www.futura-direct.co.uk)

We FUTURA Direct Ltd, England DN6 7AY declare that the cordless drill is exclusively manufactured for FUTURA Direct Ltd and has been manufactured according to our fully quality assurance procedures.