

TECHNICAL DATA SHEET



Heated Towel Rail Radiator

Product Specification

Product Codes & Finishes:	AHC73 (Chrome/White) AHA73 (Vintage Gold/White)
Product Type:	Classic, Nickel, Pewter, Antique Copper, Rubbed Bronze
Construction:	Body is of Steel Construction and is designed to conform to BS EN 442
Supply:	Suitable for closed central heating systems
Output:	2340 BTU (686 Watts)
Valve Centres:	600mm
Dimensions for Fitting:	940 (H) mm, 674 (W) mm, 128 (D) mm



Additional Information

- Chrome Plated to BS EN 248
- Includes Valves in Chrome & Gold Finish
- Suitable for Duel Fuel Installation

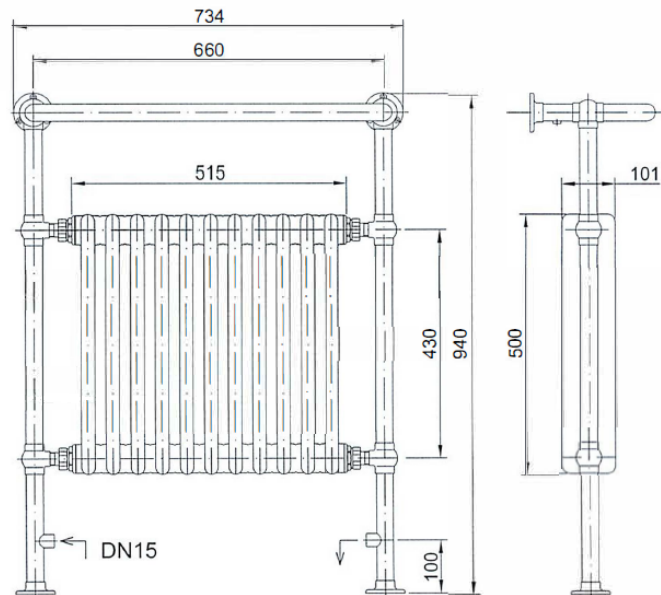
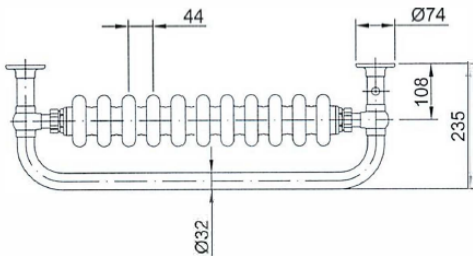

Technical Advice: For further information please call 1800 111 566
or email sales@traditionaltaps.com.au

Guarantee: 5 Year Guarantee covering manufacturing faults.



D3

Traditionaltaps.com.au 4/37 North Link Place, Virginia, Qld Telephone: 1800 111
566 Fax 07 3266 5233

Web Site: www.traditionaltaps.com.au Email: sales@traditionaltaps.com.au

The information contained on this page was correct at date of issue. Fitting dimensions are provided as a guide only. Some variation may occur due to manufacturing tolerances. Traditional Taps pursues a policy of continuing improvement in design and performance of its products and so reserves the right to change specifications without prior notice.