



TECHNICAL DATA SHEET

Clothes Horse Heated Towel Rail

Product Specification

Product Code:	AHC77
Finish:	Chrome, Nickel, Pewter, Antique
Product Type:	Copper, Bronze
Construction:	Traditional Steel & is designed to conform to BS EN 442
Supply:	Dual Fuel
Valve Centres:	470mm
Wall to valve centre:	
Output:	955 BTU (280 Watts)
Dimensions for fitting:	Height: 780mm Width: 685mm

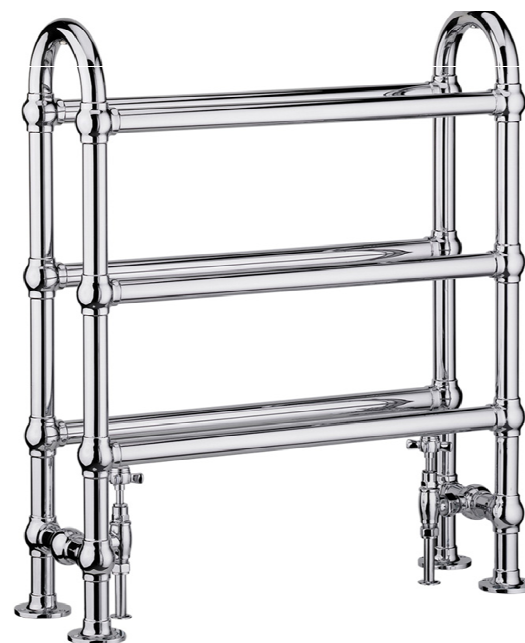

Additional Information

- AHC77 is Chrome plated to BS EN 248.
- Suitable for closed central heating systems only
- Includes valves in Chrome

Technical Advice: For further information please call 1800 111 566
sales@traditionaltaps.com.au

Guarantee: 5 years covering manufacturing faults.





TECHNICAL DATA SHEET

Clothes Horse Heated Towel Rail

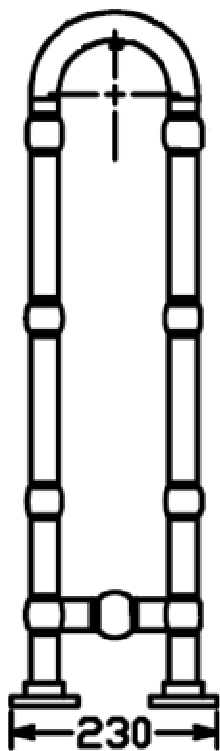
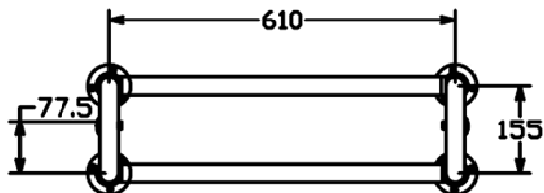

ALL TUBE $\phi 1 \frac{1}{2}$
($\phi 31.8\text{MM}$)

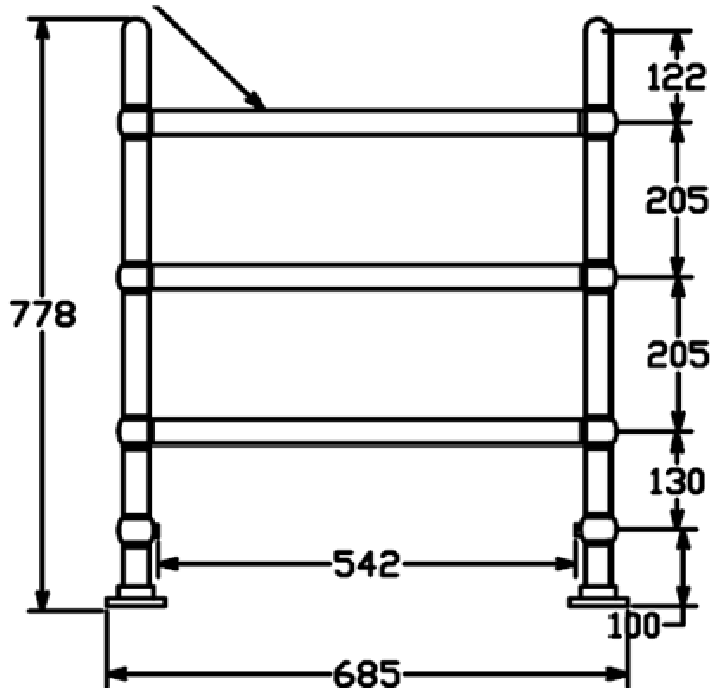

Technical Advice:

For further information please call 1800 111 5661

sales@traditionaltaps.com.au

Guarantee:

5 years covering manufacturing faults.

Traditionaltaps.com.au 4/37 North Link Place, Virginia, Qld Telephone: 1800 111 566 Fax 07 3266 5233

Web Site: www.traditionaltaps.com.au Email: sales@traditionaltaps.com.au

