

User Manual TRA3000 E-F-S-D-V-C



Title:
Date:
Product Manager:
Quality Manager:
Division Manager:
Revised:

EMC Test System TRA3000 E-F-S-D-V-C
10.07.2009
I. Saner
R. Henz
M. Lutz
05.May 2010

EMC TESTER
TRA3000 E-F-S-D-V-C



Attention Standard References and User Manual

This user manual provides information necessary for operation of the test equipment.

Throughout the users manual, standard references are used as an aid to understanding only.

The relevant standard(s) **must** be obtained and used in conjunction with this users manual



Attention contact EMC PARTNER!

Before starting any test, where specifications or limits for a particular application are not included or could not be found in the EMC PARTNER documentation (User Manual, Instruction Sheet), users must contact EMC PARTNER for clarification.

Repair costs arising from incorrect use or failure to clarify an application with EMC PARTNER remain the responsibility of the user.



Achtung EMC PARTNER kontaktieren!

Wenn für eine Anwendung die notwendigen Informationen: Parameter oder Limiten nicht aufgeführt sind in der Bedienungsanleitung UM oder in der Instruktionsanweisung IS, ist der Anwender verpflichtet EMC PARTNER zu kontaktieren bevor die Prüfung gestartet wird. Anfallende Reparatur- und Kalibrationskosten bei nicht Beachtung der Limiten in Bedienungsanleitung / Instruktionsanweisung oder unterlassen der Rückfrage werden den Kunde belastet.



ATTENTION, veuillez contacter EMC PARTNER!

Lorsque, pour une application, des limites ou des informations nécessaires ne sont pas mentionnées dans la documentation, l'utilisateur est tenu de prendre contact avec EMC PARTNER afin de recevoir les informations supplémentaires avant de commencer les tests.

Les coûts de réparation dus au non respect des limites figurant dans le mode d'emploi ou dans la notice d'utilisation ainsi que l'omission d'une demande de précision seront à la charge du client.



Declaration of Conformity

See sheets attached at the end of this user manual:

- Declaration of conformity to product standards
- Declaration of conformity to low voltage directive
- Declaration of conformity to EMC directive

Contents:

1	DESCRIPTION	9
1.1	The interference sources of the transients	9
1.1.1	Electrostatic discharge ESD	9
1.1.2	Switched inductance EFT (Burst)	9
1.1.3	Indirect lightning SURGE	10
1.1.4	Voltage interruptions, Dips	11
1.1.5	How ESD, EFT, SURGE DIPS differ	11
1.1.6	Common mode disturbances in the frequency range 0 Hz to 150 kHz	12
1.2	Overview of the TRA3000 E-F-S-D-V-C test system	13
1.2.1	TRA3000 E-F-S-D-V-C and its versions	13
1.2.2	ESD - TRA3000 System overview	16
1.2.3	EFT - TRA3000 System overview	16
1.2.4	SURGE - TRA3000 System overview	17
1.2.5	DIPS and Interruption - TRA3000 System overview	17
1.2.6	Common Mode - TRA3000 System overview	18
1.2.7	Magnetic fields - TRA3000 System overview IEC 61000-4-8 Ed.2	18
1.2.8	Magnetic fields - TRA3000 System overview IEC 61000-4-9 Ed.1	19
1.3	Technical data of the TRA3000 E-F-S-D-V-C	20
1.3.1	Electrostatic discharges ESD only valid with EXT-TRA3000 E	20
1.3.2	Electric Fast Transient EFT EXT-TRA3000 F	21
1.3.3	Coupling / De-coupling Network EFT	21
1.3.4	Lightning and switching actions SURGE (IEC 61000-4-5 Ed.2)	22
1.3.5	Coupling / De-coupling Network „CDN-SURGE“	22
1.3.6	Voltage interruption and Variation with internal Variac EXT-TRA3000 D-V	23
1.3.7	Interruption and Voltage Variation IEC 61000-4-11 Ed.2 with external Variac	24
1.3.8	DIPS circuit in accordance with IEC 61000-4-29 for d.c. power ports.	24
1.3.9	Common mode test with EXT-TRA3000 C	25
1.3.10	Power line limits on EUT power input of TRA3000	27
1.3.11	Synchronisation of TRA3000 to mains frequencies	27
1.3.12	Measuring circuit, measuring outputs	28
1.3.13	Trigger Output Levels	28
1.3.14	Control	29
1.4	Mechanical dimensions	29
1.5	Power Consumption	29
1.6	Accessories delivered with the TRA3000 F-S-D-V-C	30
2	SAFETY	33
2.1	Safety standard	33
2.2	Climatic Conditions	33
2.3	Precautionary measure during use	34
2.4	Electromagnetic Compatibility	34

2.5	The manual is an integral part of the equipment. Refer to the manual.	34
2.6	Sécurité	35
2.6.1	Normes de sécurité	35
2.6.2	Conditions climatiques	35
2.6.3	Mesures de précaution lors de l'utilisation	36
2.6.4	Compatibilité électromagnétique	36
2.6.5	Le manuel fait partie intégrante de l'équipement.	36
2.7	Sicherheit	37
2.7.1	Sicherheit Standard	37
2.7.2	Klimatische Bedingungen	37
2.7.3	Vorsichtsmassnahmen während dem Betrieb	38
2.7.4	Elektromagnetische Verträglichkeit	38
2.7.5	Dieses Manual ist Bestandteil von TRA3000 E-F-S-D-V-C und dessen Testumgebung.	38
3	MECHANICAL STRUCTURE	39
3.1	General	39
3.2	Impulse-forming Network	40
3.3	Measuring Circuit	40
3.4	Coupling / De-coupling Network CDN	41
3.5	EUT power supply at DIPS	41
4	CONTROL PANEL	43
4.1	Front panel of the TRA3000 E-F-S-D-V-C	43
4.1.1	Control part	43
4.1.2	Operation panel	46
4.2	Rear Panel of the TRA3000 E-F-S-D-V-C	48
5	PREPARATION FOR OPERATION	51
5.1	Attention, Refer to Manual	51
5.2	Operators and Service Personnel	51
5.3	Checks before operation	51
5.3.1	Optical verification of the TRA3000 E-F-S-D-V-C	51
5.3.2	Power source check	51
5.3.3	Connecting the TRA3000 E-F-S-D-V-C to the power line	51
5.3.4	EUT Power, Power source for the EUT	52
5.3.5	EUT Power, supply of the EUT with voltages differ from the public power line (Variac)	53
5.3.6	EUT Power, supply of the EUT with dc	54
5.4	Hints for the test set up according to IEC standards	55
5.4.1	Test set up EFT	55
5.4.2	ESD test set up	56

5.4.3	Test set up SURGE	57
5.4.4	Test set-up for table top equipment	59
5.5	Practical testing sequence	60
6	TESTING WITH THE TRA3000 E-F-S-D-V-C	61
6.1	Quick start of the TRA3000 E-F-S-D-V-C	61
6.1.1	Selection of a language: Deutsch, Français, Italiano, Espagnol and Beep function	63
6.1.2	Protocol possibilities	64
6.1.3	EUT - Power and EUT - Control	65
6.2	Editing test parameters	66
6.2.1	Overview of programmable test with the TRA3000 E-F-S-D-V-C	66
6.2.2	Nominal values setting	69
6.2.3	Editing „Ramp“	80
6.3	EMC test operation „RUN Mode“	88
6.4	Operating System Displays	93
6.4.1	Rolling information lines	93
6.4.2	Service access and firmware upload	94
6.4.3	Web Server	95
7	MAINTENANCE AND SERVICING	97
7.1	Maintenance	97
7.2	Verification versus Calibration	97
7.2.1	Verification Example IEC 61000-4-4 Ed.2	97
7.2.2	Calibration Example IEC 61000-4-4 Ed.2	97
7.3	Verification of the TRA3000 E-F-S-D-V-C by the user	97
7.3.1	EFT	97
7.3.2	ESD	98
7.3.3	SURGE	98
7.3.4	Interruption	98
7.3.5	Variation	98
7.4	Calibration of the TRA3000 E-F-S-D-V-C by EMC PARTNER AG	99
7.5	Service of SPD Surge Protective device	99
8	WHAT MUST BE DONE FOLLOWING FAILED OPERATION	101
8.1.1	Error caused by incorrect inputs „Generator not ready for run“	101
8.1.2	Error caused by running problem „Generator stopped“	102
8.1.3	Failure based on error at the generator „Hardware error“	103
8.2	Service; Repairs	104
8.2.1	Service Flowchart of TRA3000 System:	104
8.2.2	Data Transfer via UBS Stick	105
8.3	Spare parts list	105

8.4	Check before you contact the service of EMCP	105
8.4.1	Fuses	105
8.4.2	System Reset (Software)	106
8.5	Service department of EMC PARTNER AG	106
9	PACKAGING AND TRANSPORT	107
9.1	Packaging	107
9.2	Transport	107
10	RECYCLING / DISPOSAL	109
10.1	RoHS directive 2002/95/EG	109
10.2	WEEE directive 2002/96/EG	109
10.3	Information for dismantling	109
10.4	Parts which can be recycled	109
10.5	Parts which can not be recycled	109
11	ACCESSORIES	111
11.1	TRA3000 E-F-S-D-V-C	111
11.1.1	Circuit extension to TRA3000	111
11.1.2	CDN for Power supplies	111
11.1.3	Power fail on power supplies	112
11.1.4	CDN for data lines	113
11.1.5	CN for current injections	113
11.1.6	Items for calibration or verification	113
11.1.7	Items for test place set up	113
11.1.8	Magnetic field tests	114
11.1.9	Softwares	114
12	REMOTE PORTS	115
12.1	General	115
12.1.1	Ethernet port setting on TRA3000	115
12.1.2	IP address setting on PC	115
12.1.3	Technical Data of the RS 232C serial port	116
12.1.4	Local or Remote Control	116
12.1.5	Remote Control	117
12.2	Organisation of TRA3000 E-F-S-D-V-C Remote-Control Commands	117
12.2.1	Syntax of the Commands	117
12.2.2	Set-up Commands:	117
12.2.3	Inquire Commands	118
12.2.4	Failure messages remote control:	118
12.3	Remote Control Command set	119

12.4	Overview of TRA3000 E-F-S-D-V-C Commands	126
12.5	Software "GENECS" for TRA3000 E-F-S-D-V-C Remote Control	131
12.5.1	Setup GENECS	131
12.5.2	GENECS Windows	131
12.5.3	GENECS Library	132
12.5.4	GENECS Protocol possibilities	132
12.5.5	GENECS Log File	133
12.5.6	GENECS Preferences	134
13	APPENDIX AND CORRECTIONS	137
13.1	Appendix	137
13.1.1	Definition of the EFT Waveform	137
13.1.2	Definition of the ESD Waveform	138
13.1.3	Definition of the SURGE Waveform	139
13.1.4	DIPS Specification	140
13.1.5	VARIATION Specification IEC 61000-4-11 Ed.1	141
13.1.6	VARIATION Specification IEC 61000-4-11 Ed.2	142
13.2	Correction	143
13.2.1	Declaration of conformity to the EMC directive 89/336/EEC	143
13.2.2	Declaration of conformity to the LV directive 93/68/EEC	143
13.2.3	Declaration of conformity to the Basic Standards	143
14	GLOSSARY	145
15	INDEX	147

1 Description

1.1 The interference sources of the transients

1.1.1 Electrostatic discharge ESD

Electro Static Discharge IEC 61000-4-2 Ed.2



What causes electrostatic discharges?

A person becomes electrostatically charged by walking over an insulating floor surface. The capacity of the body can be charged to several kilovolts (1000 V). This capacity is discharged when contact is made with an electronic unit or system. The discharge is visible as a spark in many cases and can be felt by person concerned, who gets a „shock“. The discharges are harmless to humans, but not to sensitive, modern electronic equipment. The resulting current causes interference in the units or can make entire systems „crash“.

For over 25 years it has been known to the electrical industry that electrostatic discharges as encountered every day can have a disastrous effect on electronic equipment.

The cost of damage caused by ESD is difficult to assess, but amounts to billions of dollars worldwide.

The areas most affected are:

- manufacturing of integrated circuits (chips).
- the chemical industry, e.g. by explosion, fires caused by the sparks from electrostatic discharges.
- malfunctioning of process control with the secondary damage costs.

1.1.2 Switched inductance EFT (Burst)

Electric Fast Transient or Burst. IEC 61000-4-4 Ed.2

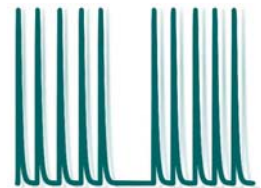

Industrial measurement and control equipment practically always operates in conjunction with conventional control units (relays, contactors). Fluorescent lamp ballast units, insufficiently suppressed coffee grinders, vacuum cleaners, drilling machines, hair dryers, universal motors, etc. can be found everywhere in the power supply system. All these, primarily inductive loads, produce interference when switched on and off. A wide range of switching transients, also called bursts, are produced with the following waveform.

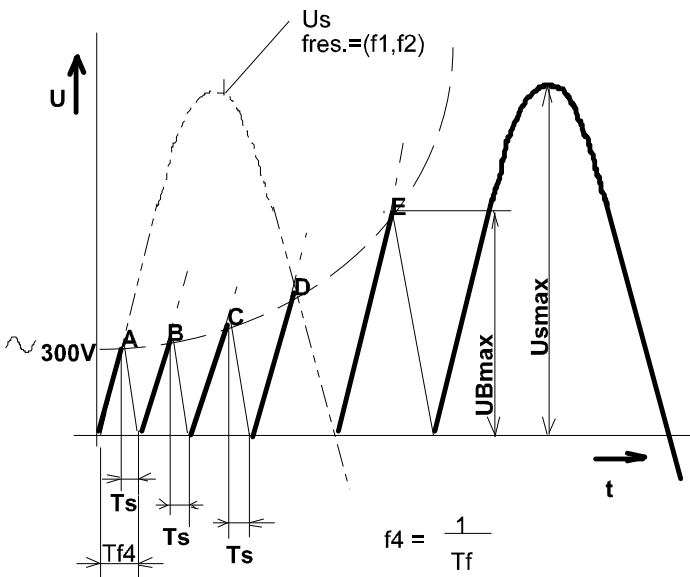

Figure: 1.0.1.2

The parameters which define the burst are:

- Rise time of the spike T_s in ns
- Repetition frequency f_4 in the range of kHz up to MHz
- Energy, some mJ
- Voltage amplitude U_{Bmax} . up to some kV
- Duration of a burst several milliseconds

The different EFT sources generate different burst waveforms. A typical burst waveform is shown in the figure above.

The impedance of the EFT source is generally high, therefore the capacitance of connected cables influences the rise time.

1.1.3 Indirect lightning SURGE

SURGE are transients with a high energy, relatively low frequency content up to some kV.

[IEC 61000-4-5 Ed.2](#)



Lightning is a daily event and occurs about 8 million times in approximately 44,000 storm centres throughout the world. That is in the order of 100 discharges per second. Measuring and recording equipment in aircraft registers one lightning strike for every 1,000 flying hours.

Product assembly and finishing in many industries depends on modern electronics. The most frequent cause of damage is overvoltage, caused either by switching action in the equipment itself or by atmospheric discharges such as lightning. In order that the overvoltages do not destroy the electronic equipment, protection elements and circuits are placed at the inputs and outputs of electronic equipment.

Consumer electronic devices, such as antenna ports on television sets, telephones, faxes, can also be influenced by atmospheric discharges. The disturbances are mostly tolerable because of their relatively low occurrence. To protect such equipment from damage protection elements and circuits are installed. Tests must be carried out to determine whether these protective circuits are really effective.

Beside lightning, switching action can also generate high energy impulses.

1.1.4 Voltage interruptions, Dips

DIPS means a sudden reduction of the voltage at a point in the electrical system, followed by voltage recovery after a short period of time from a few cycles to a few seconds.

IEC 61000-4-11 Ed.2





Voltage failures occur following switching operations, short-circuits, fuses blowing and when running up heavy loads. These are man-made faults, produced unintentionally, and include operation of domestic appliances, electronically controlled machine tools, switching operations in the public lighting system, economy lamps, etc.

The quality of the electrical power supply is increasingly becoming a central topic of discussion. Interference sources in the mains, caused by electronic power control using non-linear components such as thyristors are increasing. These devices are used in domestic appliances, such as hotplates, heating units, washing machines, television sets, economy lamps, PCs and industrial systems with speed-controlled drives. Simultaneously an increase in electronic systems sensitive to interference is apparent in all sectors of the electrical power system.

In order to achieve electromagnetic compatibility, both the interaction of the electrical equipment connected to the supply and its noise immunity must be determined.

The electromagnetic compatibility of electronic equipment must be guaranteed e. g. Europe Union 31. December 1995.

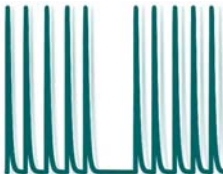
1.1.5 How ESD, EFT, SURGE DIPS differ

Characteristics	Static discharges	Switched inductance	Lightning. switching actions	Mains Interruptions
Phenomenon	"ESD"	"EFT Burst"	"Surge"	"DIPS"
Voltage U	up to 15 kV	up to 4 kV	up to 4 kV	supply source voltage
Energy at maximum voltage	approx. 10 mJ	300 mJ	300 J	-
Repetition rate	Single event	Multiple event 5 kHz	Maximum 6 Impulse / minutes	supply source frequency
Application to the different ports	Touchable metallic part (enclosure ports)	AC/DC ports, Signal and data lines	AC/DC ports, Signal and data lines	AC/DC ports
upper limit frequency	approx.. 1 GHz	approx. 200 MHz	approx. 350 kHz	approx. 100 kHz
impulse waveform	 IEC 61000-4-2 Ed.2	 IEC 61000-4-4 Ed.2	 IEC 61000-4-5 Ed.2	 IEC 61000-4-11 Ed.2

The overview of „How ESD,EFT, SURGE,DIPS differ“ shows that all four test have to be carried out because the frequency content and energy of the four transient tests are different.

1.1.6 Common mode disturbances in the frequency range 0 Hz to 150 kHz

IEC 61000-4-16 Ed.1 Amd.2



The conducted, common mode disturbances at mains frequency and its harmonics may be generated by faults on the mains power distribution system and leakage currents flowing into the earth system. The d.c. power supply network used in industrial, electrical plants and telecommunication centres may also generate d.c. common mode disturbances, particularly when either the positive or negative terminal is connected to earth.

Electrified railways will also generate disturbances at their frequency of operation (typically $16\frac{2}{3}$ Hz).

The induced disturbances are described in detail in IEC 61000-2-3 and IEC 61000-2-5. The different types of disturbances may be present simultaneously but at different levels.

Furthermore, if the power system develops a fault, the disturbance levels may be up to 10 times the reference levels given for normal operating conditions, however the fault condition disturbances are typically present for short durations only (up to about 1 s).

The disturbances at mains frequency and harmonics may affect signal ports of equipment where insufficient common mode rejection is available. Disturbances up to 1-2 kHz are mainly due to the harmonics of the power mains.

At higher frequencies the disturbances are mostly related to power electronic equipment, which may produce switching currents involving the ground system, giving rise to conducted, common mode disturbances.

1.2 Overview of the TRA3000 E-F-S-D-V-C test system

1.2.1 TRA3000 E-F-S-D-V-C and its versions

The tester TRA3000 E-F-S-D-V-C simulates transients of different interference sources. Such as: indirect lightning in electronic systems, human body electrostatic discharges, switched inductance (Burst), power supply interruptions and variations and common mode disturbance.

The test system TRA3000 E-F-S-D-V-C with accessories fulfils all requirements of the IEC basic standards IEC 61000-4-2 Ed.2 (ESD); 61000-4-4 Ed.2 (EFT); 61000-4-5 Ed.2 (SURGE) without 10/700 μ s impulse; 61000-4-11 Ed.2 (Interruption and Variations), and with accessories 61000-4-8 Ed.2 (Magnetic field 50/60Hz) and 61000-4-9 Ed.1 (Magnetic field SURGE), Common mode disturbance IEC 61000-4-16 Ed.1 Amd.2, 61000-4-29 Ed.1 dips and interruption on d.c. and IEC 61000-4-34, DIPS and Interruption >16A per phase.

If not all transient test are needed, the TRA3000 E-F-S-D-V-C tester is also available in various versions, with the possibility to upgrade the tester later to a full TRA3000 E-F-S-D-V-C test system.



The upgrade can be made by a customer. Mounting instruction (IS) will be delivered with the relevant module.

The following EXT-TRA units are available:

EXT-TRA3000 E (ESD)

	<p>Installing instruction of EXT-TRA3000 E can be found in the Instruction Sheet (IS), delivered with the EXT-TRA3000 E.</p>
--	--

EXT-TRA3000 F (Electrical Fast Transient, Burst)

	<p>Installing instruction of EXT-TRA3000 F can be found in the Instruction Sheet (IS), delivered with the EXT-TRA3000 F.</p>
--	--

EXT-TRA3000 S (Surge)

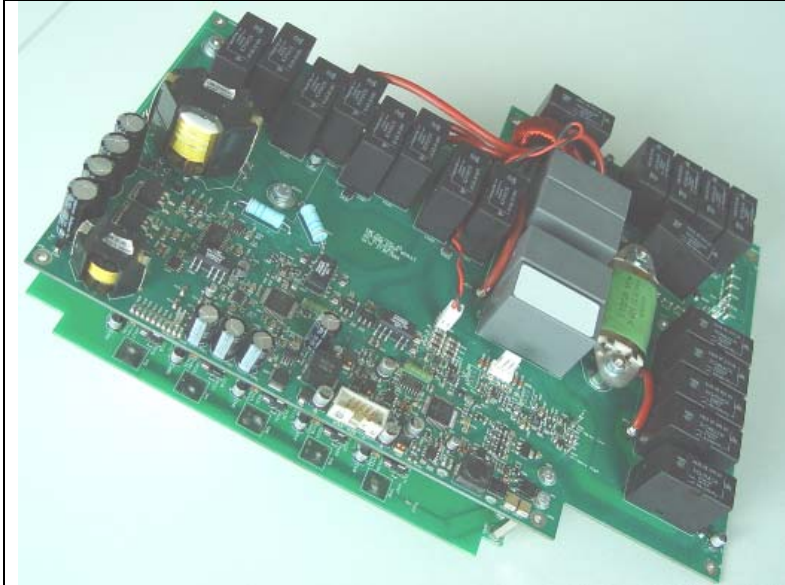

Installing instruction of EXT-TRA3000 S can be found in the Instruction Sheet (IS), delivered with the EXT-TRA3000 S.

EXT-TRA3000 D (DIPS)

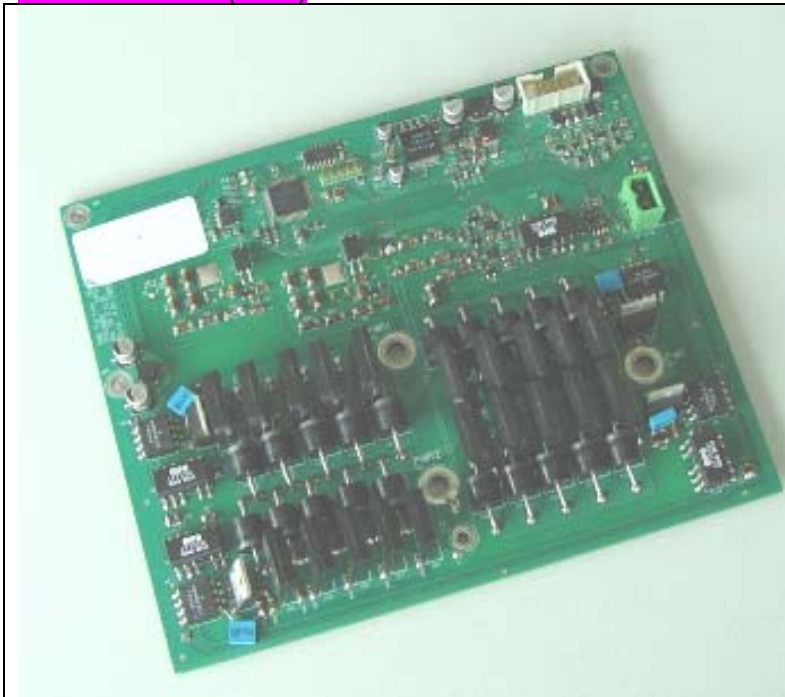

Installing instruction of EXT-TRA3000 D can be found in the Instruction Sheet (IS), delivered with the EXT-TRA3000 D.

EXT-TRA3000 V (Variation)

Installing instruction of EXT-TRA3000 V can be found in the Instruction Sheet (IS), delivered with the EXT-TRA3000 V.

EXT-TRA3000 C (Common Mode Disturbance)

Installing instruction of EXT-TRA3000 C can be found in the Instruction Sheet (IS), delivered with the EXT-TRA3000 C.

Each EXT-TRA3000 is delivered with a calibration report.

The TRA3000 F-S-D-V contains a single-phase coupling / de-coupling network, which allows a controlled superposition of the transients onto a power supply line.

All transients are generated at the same EUT power output, therefore a true single port test is possible. The TRA3000 E-F-S-D-V-C allows the automated switching of coupling paths and the programming of a large range of test sequences.

The tester TRA3000 E-F-S-D-V-C is a stand-alone equipment for automated EMC test without a PC.

1.2.2 ESD - TRA3000 System overview

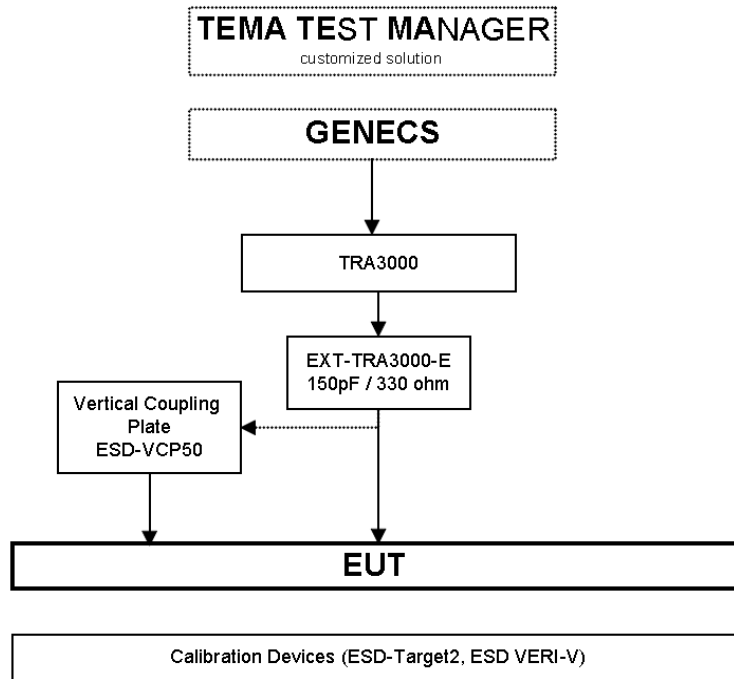

1.2.3 EFT - TRA3000 System overview

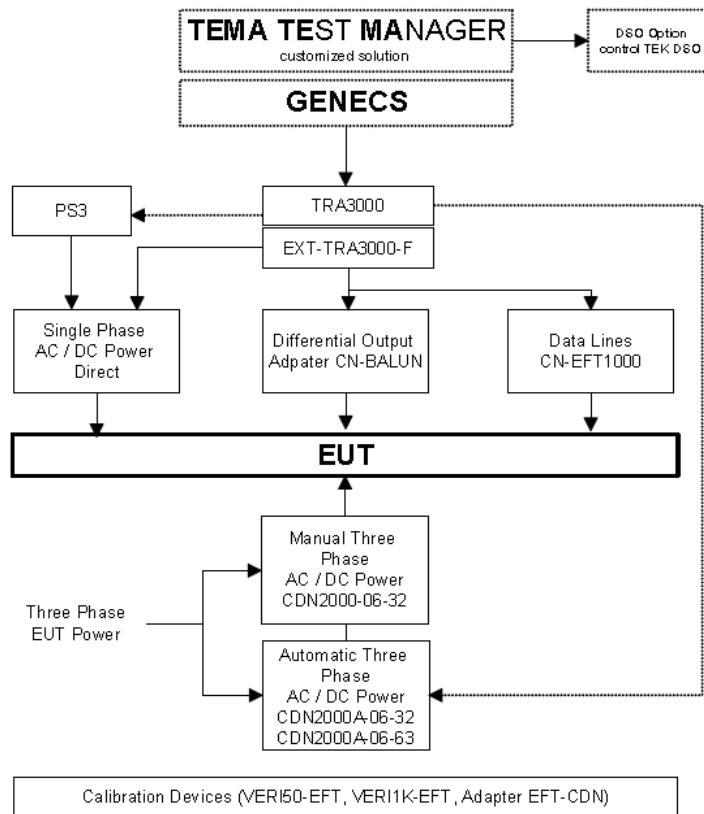

1.2.4 SURGE - TRA3000 System overview

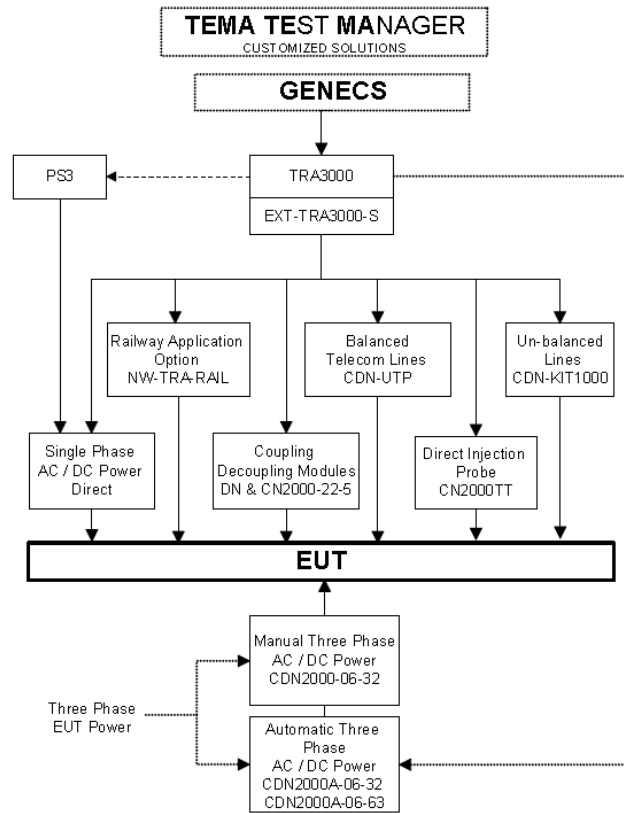

1.2.5 DIPS and Interruption - TRA3000 System overview

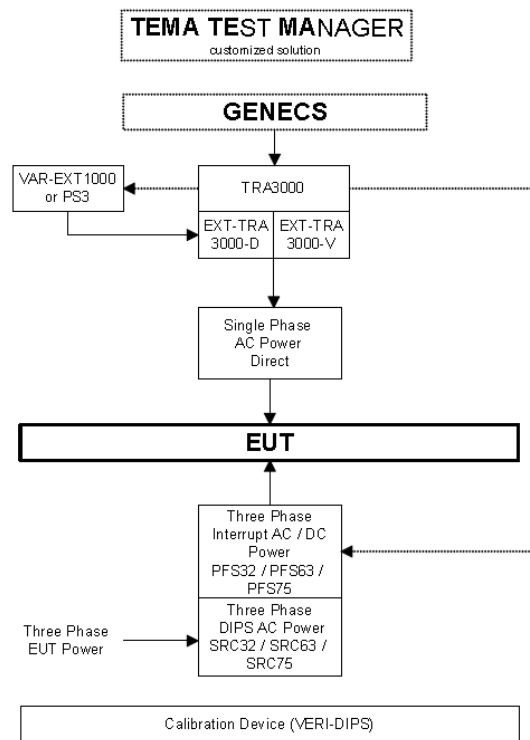

1.2.6 Common Mode - TRA3000 System overview

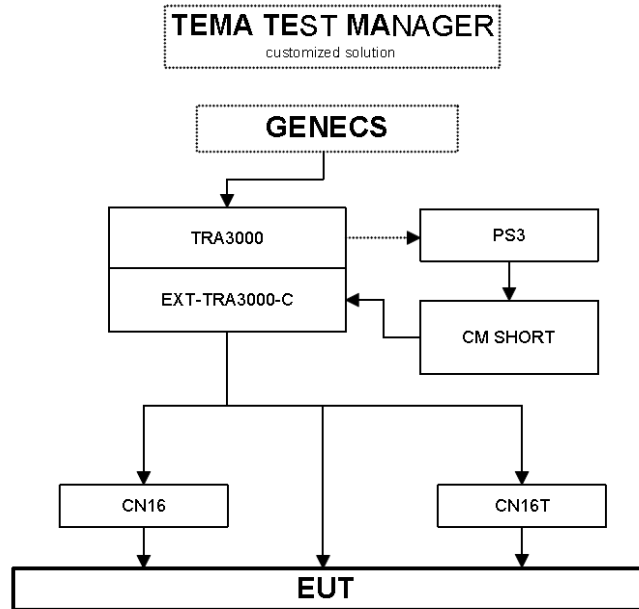

1.2.7 Magnetic fields - TRA3000 System overview IEC 61000-4-8 Ed.2

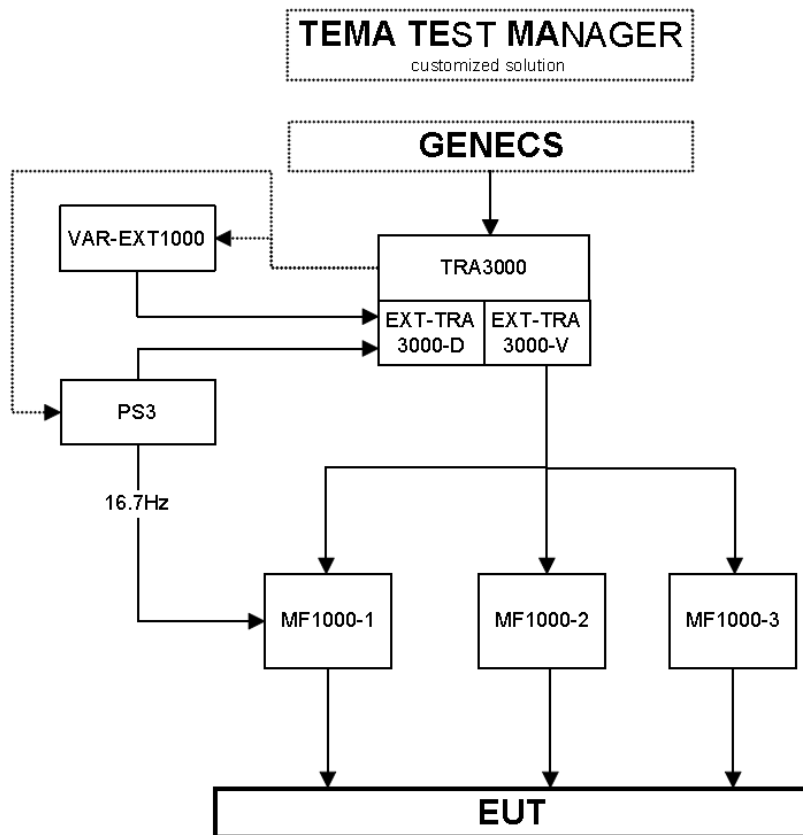

1.2.8 Magnetic fields - TRA3000 System overview IEC 61000-4-9 Ed.1

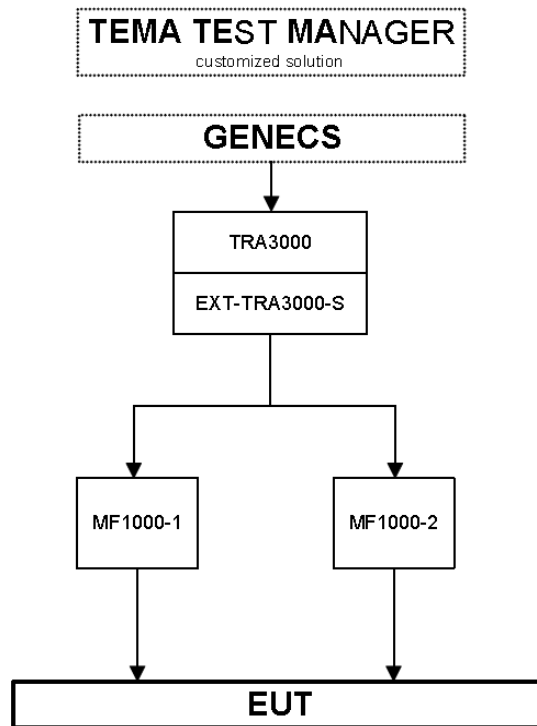

1.3 Technical data of the TRA3000 E-F-S-D-V-C

1.3.1 Electrostatic discharges ESD only valid with EXT-TRA3000 E

Energy storage capacitance	150 pF		
Discharge resistance	330 Ω		
Charging resistance	54 M Ω		
Holding time (drop to 95%)	better than 5 s		
Current rise time, 2 Ω load	0.8 ns	$\pm 25\%$	See 6.1 IEC 61000-4-2 Ed.2
Definition of current waveform:			
Current amplitude at 30 ns	4 to 16 A	$\pm 30\%$	
Current amplitude at 60 ns	2 to 8 A	$\pm 30\%$	
Voltage range „air discharge“	2 to 15 kV	$\pm 10\%$	
Voltage range „contact discharge“	2 to 10 kV	$\pm 10\%$	
First current amplitude into 2 Ω „contact discharge“	7,5 to 30 A	$\pm 15\%$	
Polarity	positive / negative; automatic switchover		
Number of discharges Detection of the number of discharges	-preselectable -count „every pulse“ -count „discharge only“. Only the impulses whereas the voltage of the discharge capacitor tropes lower then 10% of the charging voltage are counted.		1 to 29'999
Ramps	voltage amplitude changes from shot to shot, alternate polarity		
Reporting	test sequence with the number of discharges -Voltage amplitude -Polarity		
Discharge modes:	-Air discharge -Contact discharge		
Repetition of the discharges	0.05 up to 30 s Single discharge „Man“		

1.3.2 Electric Fast Transient EFT EXT-TRA3000 F

Voltage waveform into 50 Ω :	Impulse Output		IEC 61000-4-4 Ed.2
Risetime	5 ns	$\pm 30\%$	
Half time value	50 ns	$\pm 30\%$	
Voltage waveform into 1000 Ω :			
Risetime	5 ns	$\pm 30\%$	
Half time value	50 ns	- 15 ns	+ 100 ns
Adjustable voltage range	250 V to 4400 V		
Voltage amplitude into 50 Ω	125 V to 2000 V	$\pm 10\%$	
Voltage amplitude into 1000 Ω	250 V to 4000 V	$\pm 20\%$	
Source impedance	50 Ω	$\pm 10\%$	
Spike frequency	1 kHz up to 1 MHz		
Maximum Spikes per seconds	8'000 at 1000 V		1000 at 4000 V
Burst duration	0,001 ms up to 30 ms		
Burst repetition	1 ms up to 1000 ms		
Polarity	positive / negative		
Ramps	-Voltage -Spike frequency -Synchronisation -Burst duration		
High voltage output	10 nF decoupled	max. 450 V ac	

1.3.3 Coupling / De-coupling Network EFT

Maximum continuous EUT power supply voltage	280 V ac 50/60 Hz		
Maximum allowed continuous current	16 A		
Spike waveform superimposed onto the lines of the EUT power supply	within the tolerances as above		IEC 61000-4-4 Ed.1 and Ed.2 Amd.1
Coupling paths:	L-GND; N-GND, PE-GND, L+N+PE - GND L+N - GND; L+PE - GND; N+PE - GND		

1.3.4 Lightning and switching actions SURGE (IEC 61000-4-5 Ed.2)

Waveform at no load :	Impulse output		See 6.1
Front time	1.2 μ s	$\pm 30\%$	
Time to half value	50 μ s	$\pm 20\%$	
Waveform at short circuit:			
Front time	8 μ s	$\pm 20\%$	
Time to half value	20 μ s	$\pm 20\%$	
Preselectable voltage range	220V to 4100 V		
Open circuit output range	250 V to 4000 V	$\pm 10\%$	-
Short circuit output current	125 A to 2000 A	$\pm 10\%$	
Output impedance Umax / Imax	2 Ω		
Polarity	positive / negative / altn		
Ramps	-Voltage -Polarity -Synchronisation		
High voltage output "low"	maximum voltage between „low“ and earth 260 V ac		
Time between successive shots	3 s		5s at 4000 V

1.3.5 Coupling / De-coupling Network „CDN-SURGE“

Maximum allowed continuous voltage phase neutral	280 V ac 50/60 Hz	16A	
Coupling path phase- earth	9 μ F + 10 Ω	(L-PE)	
Coupling path neutral - earth	9 μ F + 10 Ω	(N-PE)	
Coupling path phase - neutral	18 μ F	(L-N)	
Coupling modes:	L-N; L-PE; N-PE, automatic coupling path switching		

Attention ! The CDN-SURGE 1,2 / 50; 8 / 20 μ s is designed for maximum power consumption at 280V rms 50/60Hz and a coupling capacitance of 18 μ F.
 If using coupling de-coupling networks from other manufacturers, the maximum power dissipation of the TRA3000 E-F-S-D-V-C must be considered. Power Line voltages higher than specified can destroy the impulse forming devices in the TRA3000 E-F-S-D-V-C. Please contact EMC PARTNER AG or a representative before using an unknown coupling network.

1.3.6 Voltage interruption and Variation with internal Variac EXT-TRA3000 D-V

Voltage range	0 to 260 V when EUT power input voltage is 230V	EUT Power	Depending on the EUT power voltage
Frequency range without variac	DC up to 400 Hz		external Source
Frequency range with variac involved	48 Hz to 60 Hz		external Source
Nominal current	16A without internal Variac involved		
Interruption with internal variac and linear load	maximum 12 A maximum 16 A		< 5s < 300 ms
Inrush current	500 A Peak	- 0%, +30%	
Interruption time	50 μ s to 30 s		phase angle selectable
Amplitude of the interruptions	continuously selectable from 0 to 100 %		IEC: 0 %, 40 %, 70 %, 80%
Phase angle for turn ON and OFF of the EUT. Selectable in range	0 to 360°	$\pm 5^\circ$	
Voltage variation with the internal variac	0 to 110 % maximum. 5A	$\pm 20\%$	2 s to 30000 s
Voltage variation with external variac	0 to 110 % maximum. 16 A	$\pm 20\%$	2 s to 30000 s
Less than 1 period More than one period d.c. interruption	Interruption within one period. Input as angle Interruption longer then one period. Input in ms Input in ms		
Ramps	-Voltage -Synchronisation angle -Interruption time		
Interruption for all kind of loads UT= voltage at EUT Power 1	DIP 100 %	% UT 0 %	0 to 16 A



For interruptions of 0 to 100% and 100% to 0% the internal Variac is not involved, therefore the test can be carried out up to 16 A. For interruption with UT =EUT Power 1 voltage not zero, the internal variac limits the EUT power current. The maximum allowed current values are listed in the table on the next page. Please be aware that different types of loads influence the maximum current.

With internal Variac:

Types of loads:		Variable power consumption maximum 2.6 kW at UT 230 V. With reduction of the voltage the current is also reduced. Examples: Ohmic -, inductive -, capacitive -, mixed loads	Constant power consumption maximum 1,2 kW at UT = 220V. With reduction of the voltage the current is increased. Example: switched power supply	voltage change in % of UT at current change 0 to 100 % UT= voltage at EUT Power 1
switching from	to			
UT	% UT	current range r.m.s	current range r.m.s	% of UT
100 %	0 %	0 to 16A	0 to 16A	0.7 %
100%	80%	0 to 10 A	0 to 5A	4%
100%	70%	0 to 9 A	0 to 6 A	4%
100%	40%	0 to 5 A	0 to 10 A	5%

Note: all values apply for switching time at %UT < 5 s

1.3.7 Interruption and Voltage Variation IEC 61000-4-11 Ed.2 with external Variac

Types of loads:		Variable power consumption maximum 3.7 kW at UT 230 V. With reduction of the voltage the current is also reduced. Examples: Ohmic -, inductive -, capacitive -, mixed loads	Constant power consumption maximum 3,7 kW at UT = 220V. With reduction of the voltage the current is increased. Example: switched power supply	voltage change in % of UT at current change 0 to 100 % UT= voltage at EUT Power 1
switching from	to			
UT	% UT	current range r.m.s	current range r.m.s	% of UT
100 %	0 %	0 to 16A	0 to 16A	0.7 %
100%	80%	0 to 12.8 A	0 to 20A	4%
100%	70%	0 to 11.2 A	0 to 23 A	4%
100%	40%	0 to 6.5 A	0 to 40 A	5%

Note: all values apply for switching time at %UT < 5 s

1.3.8 DIPS circuit in accordance with IEC 61000-4-29 for d.c. power ports.

Voltage range d.c.	20 to 300 V	EUT Power	
Current range	0 up to 16A		
Inrush current capability at 110 V	220A Peak	- 0%, +30%	See 6.1.1
Interruption time	1ms up to 29999 ms		
Rise and fall time at 100 Ohm load	between 1 µs and 50 µs		See 6.1

IEC 61000-4-29 page 19:

The use of a generator with higher or lower voltage/current capability is allowed provided that the other specifications are preserved. The test generator steady state power/current capability shall be at least 20% greater than the EUT power/current ratings.

1.3.9 Common mode test with EXT-TRA3000 C

1.3.9.1 General Generator Specification

Voltage setting range	0.1 to 35V		
Source impedance	50 Ohm	± 10%	
Test frequencies	DC, 16,7Hz, 50Hz and 60Hz		
Test time	1 up to 30'000s		
Open circuit output voltage range	Vmin 0.1V Vmax 30V	-10% +10%	

1.3.9.2 Characteristics and performance of the generator for d.c. tests

Test levels for continuous operation	1, 3, 10, 30 V		
Test levels for short time operation	10, 30 V	1 to 10s	Selectable short duration time
Switching time at d.c. ON/OFF	Between 1 - 5 µs		

1.3.9.3 Characteristics and performance of the generator for a.c. tests

Test levels for continuous operation	1, 3, 10, 30 V		
Test levels for short time operation	10, 30 V	1 to 10s	Selectable short duration time
Test frequencies	16,7Hz, 50Hz and 60Hz		
Synch turn ON for a.c.	0°	± 5%	

1.3.9.4 Characteristics and performance of the generator for tests in the frequency range 15 Hz-150 kHz

Frequency range	15Hz up to 150kHz	-10%, +10%	
Test levels	1, 2, 3, 4,		
Decade time	10s up to 1000s		
Step Sizes of the preceding frequency value	2 to 10%		
Voltage changes	20dB / decade. 20dB / decade.	Decreases Increases	15 up to 150Hz 1.5kHz up to 15kHz

No test level is defined below 15Hz, excluding d.c.

For further information about short duration disturbance test see EXT-TRA3000 C-SHORT instruction sheet.

1.3.10 Power line limits on EUT power input of TRA3000

Power line voltages greater than 280V and frequencies higher than 70Hz are the limit for the power dissipation of the SURGE circuit. The TRA3000 measures the voltage and the frequency. When higher voltages or frequencies are measured the following modes will be activated:

Gating Mode	Gating Time	Gating activated
0	No Gating	$F < 70\text{Hz}$ & $V < 280\text{Vrms}$
1	0.5 Seconds	$F < 70\text{Hz}$ & $V \geq 280\text{Vrms}$
2	0.1 Seconds	$F \geq 70\text{Hz}$

Explanation of the gating mode:

The coupling path between the SURGE circuit and the power line will be opened and only closed during Surge release.

Possible states during "RUN" modes:

0 → 1 0 → 2 1 → 2

1.3.11 Synchronisation of TRA3000 to mains frequencies

Synchronisation to EUT power input

A minimum voltage of 30V rms must be applied to the power input on the rear of the TRA3000 (PWR1 or PWR2) to synchronize the Surge to the mains. The LED within the connector on the front panel indicates a proper synchronisation.

Synchronisation to Impulse Out

Generally we recommend the synchronisation to the TRA3000 (PWR1 or PWR2). The voltage at the PWR inputs is limited to 280Vrms.

That the synchronisation via the Impulse Output (Synchro on Output) works correct, the following condition must be fulfilled:

If frequency $\leq 100\text{Hz}$, than the voltage must be $> 100\text{Vrms}$

or

If frequency $> 100\text{Hz}$, than the voltage must be $> 150\text{Vrms}$



Caution

When PWR1 is turned OFF also the synchronisation signal is turned OFF. TRA3000 displays the following message.

→ Generator Malfuction „No synchronisation signal“

1.3.12 Measuring circuit, measuring outputs

Monitor outputs for measuring equipment e. g. oscilloscope:

Outputs	Relations	Tolerances	Maximum values
SURGE Voltage	10 V equals 4000 V	5 %	4800 V
SURGE Current	10 V equals 2000 A	5 %	2400 A
EUT Power Voltage	10 V equals 400 V	3 %	480 V
EUT Power Current	10 V equals 100 A	5 %	500 A

Numeric measurements e.g. measuring values in the display and in the report.

Display	Range	Tolerances	
SURGE Voltage Peak value	0 to 5000 V	3 %	
SURGE Current Peak value	0 to 2500 A	3 %	
EUT Power Voltage (rms)	0 to 280 V	3 %	
EUT Power Current (rms)	0 to 18 A	3 %	

1.3.13 Trigger Output Levels

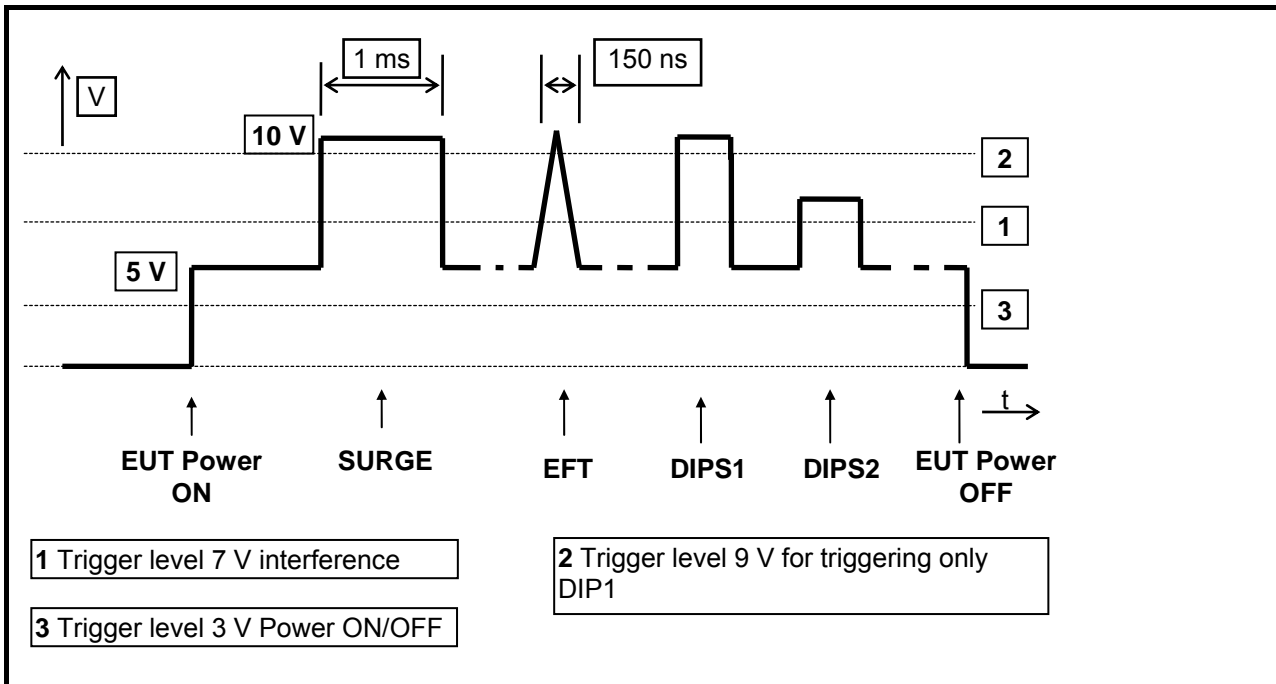

1.3.14 Control

Set-up memory	Up to 200 test set-ups can be stored
Test sequences	the set-ups can be linked serially
Ramps	automatic linear variation of one parameter e.g. voltage, frequency etc.
Synchronisation on different power line frequencies	10 up to 400 Hz
Impulse release	Manual or automatic
Failure detection on EUT	-External Input EUT failed -Manual detection -Selectable limit value for impulse voltage and current for SURGE
Safety switching	Emergency stop Switch off the EMC Test and the EUT power
Control of an external variac	separate remote-control output
Failure analysis report, servicing	USB port with USB stick. USB stick delivered with TRA3000
Control of external CDN	via RS 485 port
Remote control from GENECS	Ethernet
Remote control customized program	RS232

1.4 Mechanical dimensions

Tester -Type	Dimensions [mm]	Weight [kg]	Versions
	width x depth x height		
TRA3000 E-F-S-D-V-C and all Versions	550 x 600 x 190	See standard accessories list	19" 4 UH

1.5 Power Consumption

The power line input is located on the rear side of the TRA3000 E-F-S-D-V-C.

Voltage between phase and neutral	100V up to 240V	50 up to 60Hz
Power consumption	Standby: power cord connected, switch turned "OFF"	< 0.5W
	Power "ON" no EMC test running	15W
	EMC test running VA maximum	<800VA

Power cords see next paragraph „Accessories delivered with the TRA3000

1.6 Accessories delivered with the TRA3000 F-S-D-V-C

Legende:												
			+ = mounted, built in x = to be selected (1) = only when ordered separately 1? or x? = not yet available 0 = not possible / not available P = Plug-In B = Box S = Set + (e.g. 4+) = outputs on top e.g. 4UH plus additional height									
Pos. No.	Category	Article No.	Component Stock No.	Short Description	Color	Dimensions	Weight kg	A - INSTRUCTIONS D	A - INSTRUCTIONS E	A - PROTOCOL	TRA3000 F-S-D-V-C	
1	AA			S/N = SN or only LOGO = L		-/-	-/-				SN	
2	AA			Unit height in UH		-/-	-/-				4	
3	AA			Dimensions l x w(d) x h cm		-/-	-/-				57x45x19	
4	AA			Weight in KG		-/-	-/-				27	
10	AD		-/	User Manual		on CD	-/-				1	
11	AD		-/	Calibration Protocol		A4	-/-				1	
14	AS		-/	Software EMCP		1 CD	-/-				1	
113	CA	ZUB158	103081	MC safety cable with protected banana plug x3 (1x black, 1x blue, 1x yellow-green)	black, blue, yellow-green	3x 2m					1	
114	CA	ZUB261	104537	Patch cord cat. 5e FTP type crossover to CTRL3000	red	3m					1	
122	CA	ZUB178	103127	Power cord 3 pole AU/NZ (10A)	black	2m					x	
123	CA	ZUB049	103123	Power cord 3 pole CH (10A)	grey	2m					x	
124	CA	ZUB050	103124	Power cord 3 pole DE SCHUKO (16A)	grey	2m					x	
125	CA	ZUB051	103126	Power cord 3 pole GB (10/13A)	grey	2m					x	
126	CA	ZUB179	103129	Power cord 3 pole IN (10A)	black	2m					x	
127	CA	ZUB052	103125	Power cord 3 pole US (16A)	grey	2m					x	
187	CO	ZUB262	104539	USB Stick 2GB	black / silver	55x20x10mm					1	
229	DI	ZUB097	104370	MC bridge	black						2*	
271	FU	ZUB110	104373	Spare fuse 16AT		6.3 x 32mm					2	
274	FU	ZUB105	104386	Spare fuse 4AT		5 x 20mm					1	
275	FU	ZUB106	104377	Spare fuse 5AT		5 x 20mm					1	

2 Safety

The TRA3000 E-F-S-D-V-C belongs to Safety class 1

2.1 Safety standard

The TRA3000 E-F-S-D-V-C fulfils the requirements of the safety standards IEC 61010 for laboratory measurements equipment „Safety requirements for electrical measuring, control and laboratory equipment“. Based on EN 61010 the declaration of conformity to low voltage directive (LVD 73/23/EEC O.J.N° L77, 1973-03-26) is given.



This manual is an integral part of the TRA3000 E-F-S-D-V-C tester. The instructions contained in the manual regarding operation and the test set up are to be strictly observed.

2.2 Climatic Conditions

The TRA3000 E-F-S-D-V-C contains high voltage circuits in integrated form. EMC PARTNER only guarantees a correct functioning of the tester TRA3000 E-F-S-D-V-C and the associated accessories, if the TRA3000 E-F-S-D-V-C is operated in the climatic conditions specified.

Temperature	15 °C to 35 °C	
Relative humidity	45 % to 75 %	
Atmospheric pressure	86 kPa to 106 kPa	(860 to 1060 mbar)
Not influenced by:	direct solar radiation, rain or condensation water, dust or larger electro magnetic fields as specified in the EMC compatibility chapter.	

The TRA3000 E-F-S-D-V-C should be operated in a dry, clean room. If for any reason condensation water is present in the TRA3000 E-F-S-D-V-C, then no TRA3000 operation should be started before the tester is thoroughly dry.



It is strictly forbidden to operate the TRA3000 E-F-S-D-V-C in rooms with a gas explosion risk. The high voltage of the TRA3000 E-F-S-D-V-C can generate sparks, which could ignite the gas.

People with heart pacemakers should not be in the vicinity of the test set up during operation.

2.3 Precautionary measure during use

The TRA3000 E-F-S-D-V-C generates high voltages. The energy content of the SURGE impulse is high and can be dangerous with improper use. It is wise to observe the following rules:

• Never touch the EUT when a test is in operation.
• Touch no connectors of interconnection cable when a EMC test is in operation.
• The high voltage of the TRA3000 E-F-S-D-V-C and the power on the EUT must be turned off before a manipulation on the EUT is carried out.
• For all services, e.g. check of the fuses, the power cord must first be unplugged.

The TRA3000 E-F-S-D-V-C must be connected to power line with a safety ground. If an isolation transformer is involved in TRANSIENT supply the secondary side of the isolating transformer must be grounded.

2.4 Electromagnetic Compatibility

The outputs of the TRA3000 E-F-S-D-V-C and the links between TRA3000 E-F-S-D-V-C and the EUT can emit disturbances. Please consider the national PTT rules.

The Test System TRA3000 E-F-S-D-V-C should not be operated near sensitive measuring and control systems.

The TRA3000 E-F-S-D-V-C fulfils the following immunity requirements:

• Electrostatic discharge	Level 4 (8 kV)	(IEC 1000-4-2)
• Burst EFT	Level 4 (4 kV)	(IEC 1000-4-4)
• SURGE	Level 3 (2 kV)	(IEC 1000-4-5)



2.5 The manual is an integral part of the equipment. Refer to the manual.

This manual is an integral part of the TRA3000 E-F-S-D-V-C. The safety rules and precautions in the manual must be observed. EMC PARTNER and their representatives are not responsible for damage to persons and equipment by not observance of safety rules and precautions in the manual.

2.6 Sécurité

L'appareil de test TRA3000 E-F-S-D-V-C est un équipement de la classe de sécurité 1

2.6.1 Normes de sécurité

L'appareil de test répond aux exigences des normes de sécurité CEI 61010 (Règles de sécurité pour appareils électriques de mesurage, de régulation et de laboratoire) et à la norme de sécurité VDE 0104 (Circuits de sécurité, lampes d'avertissement ou connecteurs pour les lampes d'avertissement). Le produit satisfait aux exigences de la directive basse tension LVD 73/23/CEE (JO n ° L77, 1973-03-26). L'observation de cette directive a été contrôlée selon DIN EN 61010 (correspond à CEI 61010).



Ce manuel est une partie intégrante de l'appareil de test TRA3000 E-F-S-D-V-C. Les instructions contenues dans le manuel en ce qui concerne le fonctionnement et l'installation d'essai, doivent être strictement respectées.

2.6.2 Conditions climatiques

L'appareil de test contient des circuits haute tension sous forme intégrée. EMC PARTNER ne garantit le bon fonctionnement de l'appareil et des ses accessoires, que s'il est utilisé dans les conditions climatiques spécifiées ci-dessous.

Température	15 ° C à 35 ° C	60 à 90 ° F
Humidité relative	45% à 75%	12,9 à 15,4 psi
Pression atmosphérique	86 kPa à 106 kPa	(860 à 1060 mbar)
Ne pas exposer à:	rayonnement solaire direct, pluie ou eau de condensation, poussière ou un niveau plus important de champ électromagnétique que spécifié dans le chapitre sur la compatibilité électromagnétique.	

L'appareil devrait être utilisé dans un endroit propre et sec. Si pour une raison quelconque de l'eau se condense dans l'appareil, aucun test ne devra être effectué avant que l'appareil soit sec.

Il est strictement interdit de faire fonctionner l'appareil dans des endroits contenant des gaz avec risque d'explosion. La haute tension de l'appareil peut générer des étincelles qui pourraient enflammer le gaz.



Les personnes portant un stimulateur cardiaque ne doivent pas être à proximité de l'installation d'essai en cours d'opération

2.6.3 Mesures de précaution lors de l'utilisation

L'appareil de test TRA3000 E-F-S-D-V-C est une source de puissance. L'énergie à la sortie de celle-ci est élevée et peut être dangereuse si elle n'est pas utilisée correctement. Il est conseillé d'observer les règles suivantes:

- | |
|--|
| • Ne jamais toucher le EST (équipement sous test) quand un test est en fonctionnement |
| • Ne jamais toucher les connecteurs ou les câbles quand un test CEM est en marche. |
| • Avant toute manipulation de l'EST, s'assurer que l'appareil de test est désactivée et que l'EST est déclenché. |
| • En cas de service, comme vérifier les fusibles, le cordon d'alimentation doit être débranché. |

L'appareil de test TRA3000 E-F-S-D-V-C doit être connecté à une ligne électrique avec liaison à la terre. Si un transformateur d'isolement est utilisé, le côté secondaire doit être mis à la terre.

2.6.4 Compatibilité électromagnétique

Les sorties de l'appareil de test TRA3000 E-F-S-D-V-C et les câbles de connexion du système à l'EST peuvent émettre des perturbations. Veuillez s'il vous plaît examiner les règlements nationaux applicables à l'environnement local.

L'appareil de test TRA3000 E-F-S-D-V-C ne devrait pas être utilisé à proximité de systèmes de mesure et de contrôle sensibles.

L'appareil satisfait aux exigences d'immunité suivantes:

• décharges électrostatique	niveau 4 (8 kV)	(IEC 61000-4-2)
• Burst EFT	niveau 4 (4 kV)	(IEC 61000-4-4 Ed.2)
• SURGE	niveau 3 (2 kV)	(IEC 61000-4-5 Ed.2)

Reportez-vous au manuel



2.6.5 Le manuel fait partie intégrante de l'équipement.

<p>Ce manuel fait partie intégrante du TRA3000 E-F-S-D-V-C. Les règles de sécurité et les précautions à prendre dans le manuel doivent être respectées. EMC PARTNER et ses représentants ne sont pas responsables des dommages causés aux personnes et au matériel découlant du non respect des règles de sécurité et des précautions à prendre citées dans le manuel.</p>
--

2.7 Sicherheit

TRA3000 E-F-S-D-V-C entspricht der Schutzklasse I. TRA3000 E-F-S-D-V-C darf nur mit einem Versorgungskabel mit enthaltenem Schutzleiter betrieben werden.

2.7.1 Sicherheit Standard

TRA3000 E-F-S-D-V-C erfüllt alle Anforderungen nach Sicherheit Standard IEC61010 „Safety requirements for electrical equipment for measurement, control and laboratory use. Basierend auf EN 61010 (IEC 61010) ist die Deklaration zur Einhaltung der Niederspannungsrichtlinie LVD 73/23/EEC (O.J. N° L77, 1973-03-26) gegeben.



Dieses Manual ist Bestandteil des TRA3000 E-F-S-D-V-C Generators. Alle im Manual befindlichen Hinweise und Anweisungen sowie Testkonfigurationen sind strikte einzuhalten.

2.7.2 Klimatische Bedingungen

Die unten aufgeführten klimatischen Bedingungen müssen für einen einwandfreien Betrieb eingehalten werden.

Temperatur	15 °C bis 35 °C	60 bis 90°F
Relative Luftfeuchtigkeit	45 % bis 75 %	12.9 bis 15.4 PSI
Atmosphärischer Druck	86 kPa bis 106 kPa	(860 bis 1060 mbar)
Keine Einwirkung von:	Bei direkter Sonneneinstrahlung, Regen, Staub, starken elektromagnetischen Felder als spezifiziert unter "Elektromagnetische Verträglichkeit"	

TRA3000 E-F-S-D-V-C darf nur in trockener und sauberer Umgebung betrieben werden. Ist aus irgendwelchen Gründen Kondenswasser im TRA3000 E-F-S-D-V-C zu erkennen, muss TRA3000 E-F-S-D-V-C vor Inbetriebnahme vollständig austrocknen.

> TRA3000 E-F-S-D-V-C darf nicht in explosionsgefährdeten Zonen betrieben werden.
> Personen mit Herzschrittmacher sollten sich während dem Betrieb nicht in unmittelbarer Nähe aufhalten.



2.7.3 Vorsichtsmassnahmen während dem Betrieb

TRA3000 E-F-S-D-V-C kann Hochspannung an den Anschlüssen führen. Bei unsachgemässer Bedienung entstehen grosse Gefahrenquellen. Folgende Regeln müssen beachtet und eingehalten werden.

Nie während einem Test den Prüfling (EUT) berühren
Nie Steckverbindungen oder Kabel berühren wenn ein EMC Test abläuft.
Vor dem Berühren des Prüflings sicherstellen, dass dieser Spannungslos ist. Entladezeiten interner Speicherladungen beachten.
Für alle Servicearbeiten (Sicherungswechsel) muss das Versorgungskabel (MAINS SUPPLY) aus gesteckt werden.

Der TRA3000 E-F-S-D-V-C darf nur an ein Speisernetz mit Nulleiter und Schutzerde angeschlossen werden. Wenn ein Isolationstransformator verwendet wird muss die Sekundärseite mit der Schutzerde verbunden werden.

2.7.4 Elektromagnetische Verträglichkeit

Der Power Output von TRA3000 E-F-S-D-V-C und die Anschlusskabel zum Prüfling können Störfelder abstrahlen. Die örtlichen Bestimmungen müssen berücksichtigt werden.

TRA3000 E-F-S-D-V-C nicht in unmittelbarer Nähe von empfindlichen Messgeräten betrieben. Die Messergebnisse könnten beeinflusst werden.

TRA3000 E-F-S-D-V-C erfüllt die folgenden Störfestigkeiten:

Elektrostatische Entladung	Level 3 (6kV / 8kV)	(IEC 61000-4-2)
Burst EFT	Level 3 (2kV)	(IEC 61000-4-4)
SURGE	Level 2 (1kV)	(IEC 61000-4-5)

Beachten Sie alle Angaben in der Bedienungsanleitung



2.7.5 Dieses Manual ist Bestandteil von TRA3000 E-F-S-D-V-C und dessen Testumgebung.

Die enthaltenen Sicherheitsbestimmungen und Vorsichtsmassnahmen müssen eingehalten werden. Bei deren Nichteinhaltung übernimmt EMC PARTNER und deren Vertreter bei Schaden an Personen oder Messeinrichtungen keine Verantwortung.

3 Mechanical structure

3.1 General

The TRA3000 E-F-S-D-V-C is ideal for running tests in development/test laboratory environments and for outdoor service on larger systems. For outdoor service, the TRA3000 E-F-S-D-V-C can be fitted into a military case.

For better understanding, the TRA3000 E-F-S-D-V-C will be divided into two parts:

- The left hand part of the TRA3000 E-F-S-D-V-C contain the control and measurements. The left hand side of the front panel, is called the control panel.
- The right hand part contains all high voltage circuits, such us high voltage source, high voltage switches, the impulse-forming network and the coupling / de-coupling network. This part is called the operation panel.

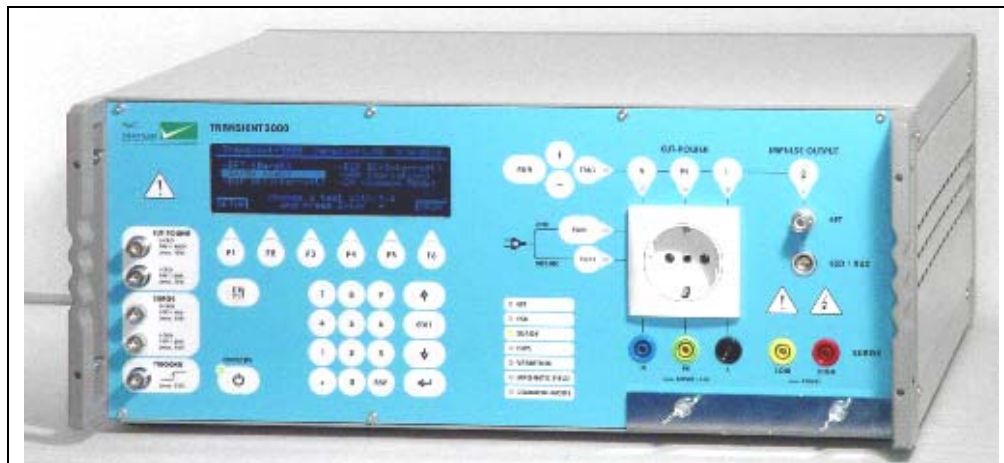

Fig.3.1

The power connections of the TRA3000 E-F-S-D-V-C and the EUT are located on the rear panel. With the EUT power inputs on the rear side and the outputs on the front side an optimum de-coupling is guaranteed. This arrangement allows test set-up without parallel-running cables.

The TRA3000 E-F-S-D-V-C is available with different options:

Standard with handles on both side as showed in Figure 3.1. This version is recommended for use in development and EMC test laboratories.

19" insert version. The handles are removed and angle brackets are fixed on both sides for fitting the TRA3000 E-F-S-D-V-C in a 19" rack. When the TRA3000 is equipped with an EFT circuit the EFT output must be maximum 50 cm above the reference ground plane.

Standard with handle in a military case. This version is recommended for outdoor EMC testing.

3.2 Impulse-forming Network

Behind the operation panel, the high voltage source, the polarity change-over switch, the impulse capacitors, the semiconductor switch and the impulse forming networks are located.

The impulse capacitor C_s is charged by the high voltage source. The discharge of the high voltage capacitor is done via the semiconductor switches. The different impulses are formed by the different impulse forming networks.

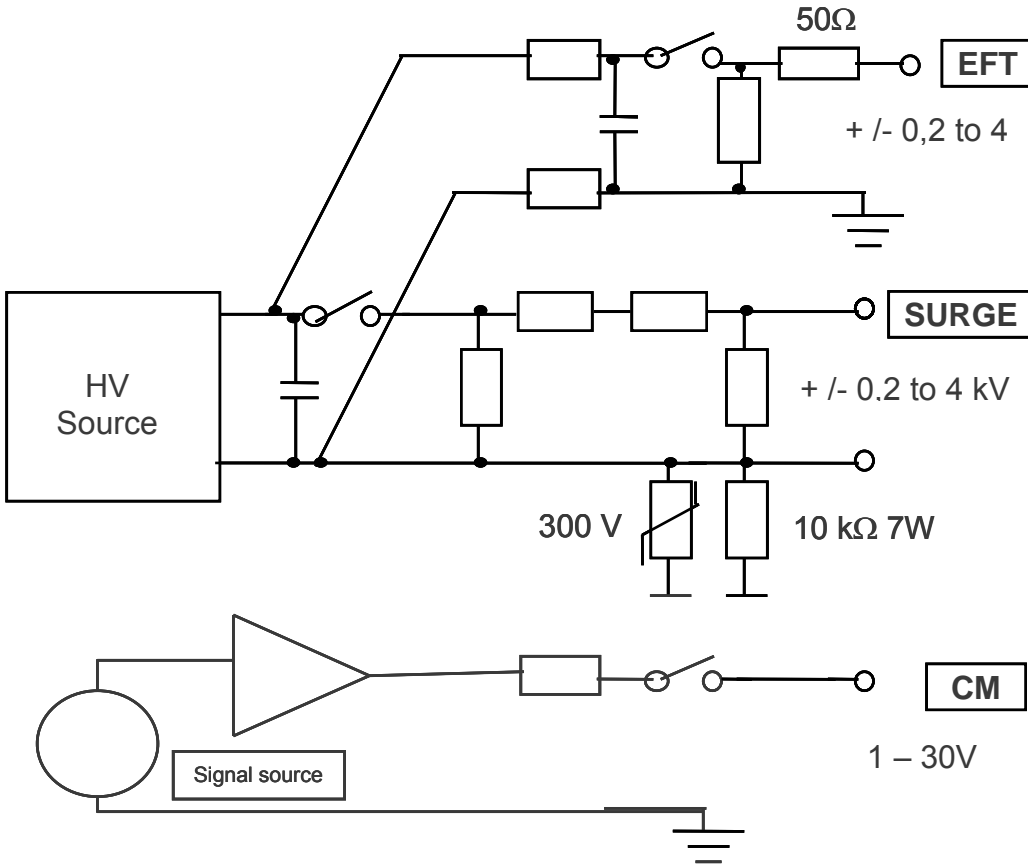

3.3 Measuring Circuit

The SURGE impulse voltage is measured differentially with two internally-located voltage dividers. The current is measured with a current monitor with differential amplifier. The peak values of voltage and current are memorised and shown in the display. With the two CRO outputs, the voltage and current waveform can be monitored on an oscilloscope.

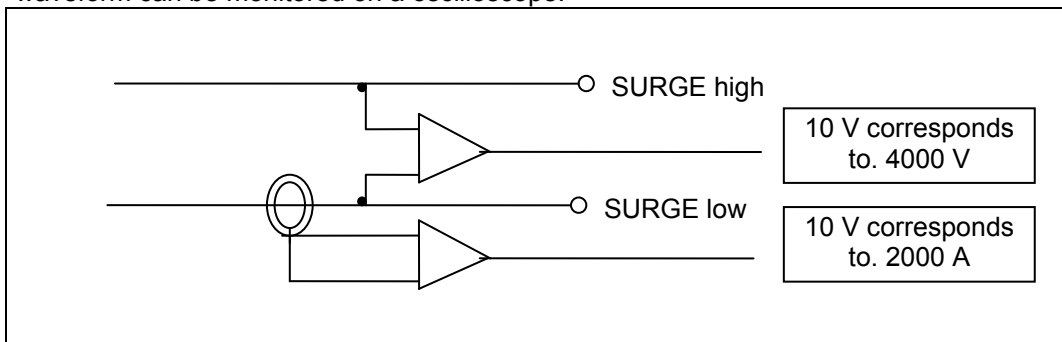

fig. 3.2

3.4 Coupling / De-coupling Network CDN

The coupling / de-coupling network (CDN) of the TRA3000 E-F-S-D-V-C allows the superimposition of the EFT or SURGE impulses onto the power line of the EUT. Switching of the different coupling paths can be programmed. For the voltage DIPS test, the de-coupling network is automatically by-passed.

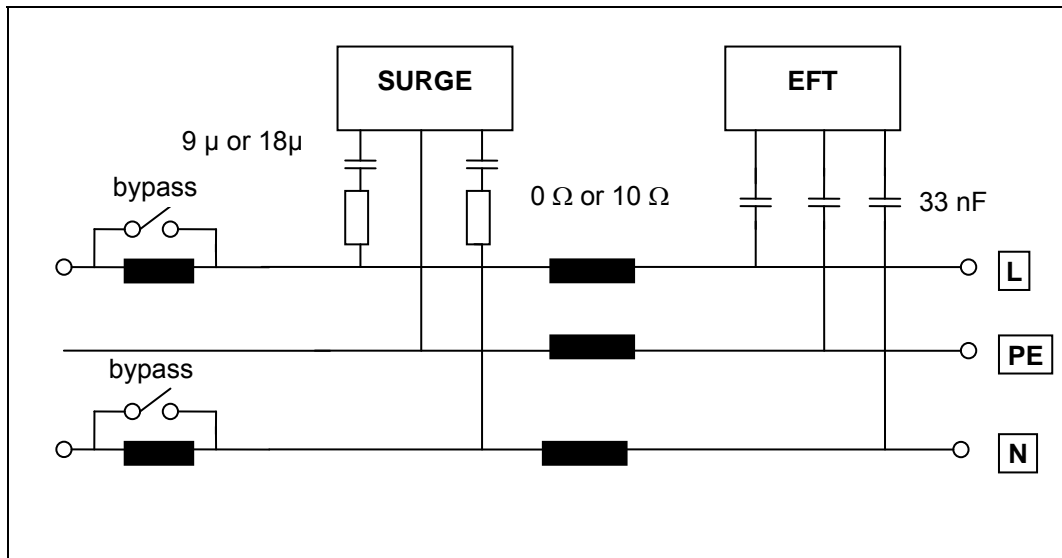

fig. 3.3

3.5 EUT power supply at DIPS

In the operation mode (DIPS voltage interruption), the switch S1 turns on the EUT Power 1 power source (undisturbed level). S2 turns on the power to EUT Power 2 (disturbed level). The internal variac can be replaced by an external variac or PS3 power supply and therefore the EUT Power 2 can be generated by internal or external means.



For DIP testing, the NEUTRAL must be close to earth potential (PE). If voltage is present on the Neutral an error will be shown on the TRA3000 E-F-S-D-V-C display. If the Neutral is not close to earth potential, an isolation transformer must be used between the mains supply and TRA3000 E-F-S-D-V-C input..

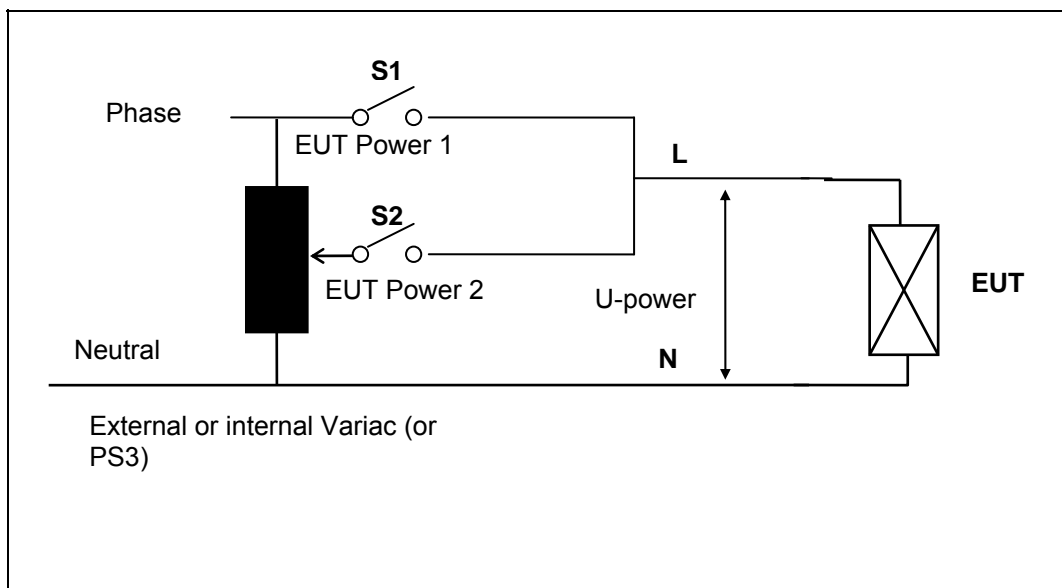

fig. 3.4

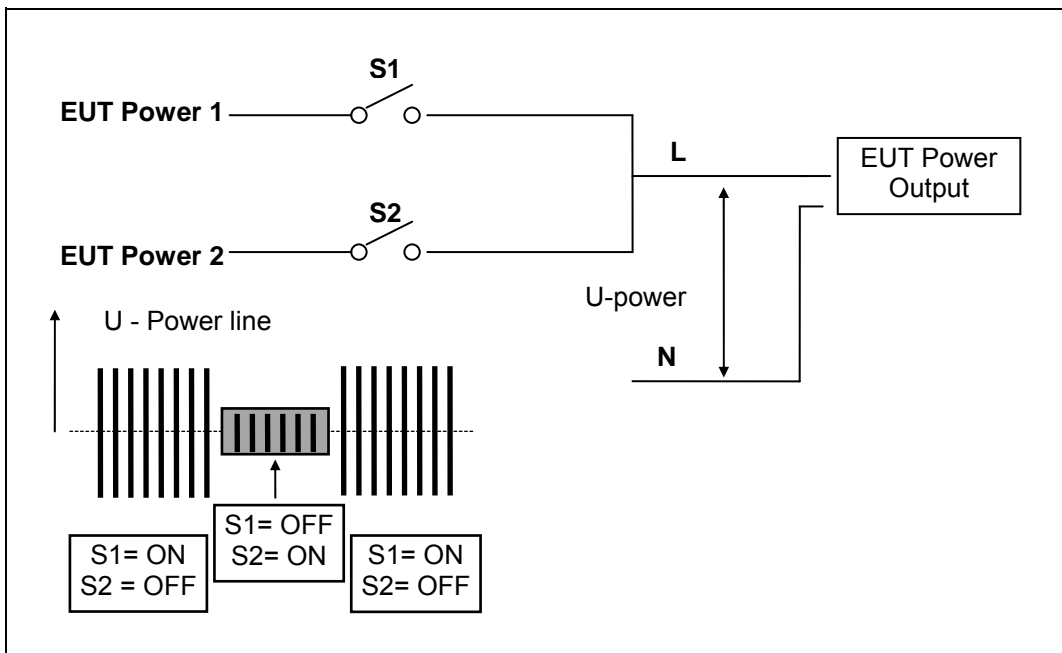

Fig. 3.4

At DIPS to 0 % of the power line voltage, two operating conditions can be differentiated:

- A) Switch S1 is opened, the voltage of the power decreases at the EUT with the discharge constant of the EUT (High Z at 0% = ON)
- B) Some μ s after switch S1 has opened, switch S2 will be closed and the EUT will be discharged via the circuit EUT Power 2 (High Z at 0% = OFF).

AT High - Z Mode = OFF and large capacitive loads, the large capacitance will be discharged via the internal variac at the beginning of the interruption. A large current will result, if an interruption to 0% of the power line voltage is generated. To avoid reducing the life span of the carbon contact electrode of the variac, it is recommended to make a short circuit with an external bridge between L2 and N of EUT Power 2.

4 Control Panel

4.1 Front panel of the TRA3000 E-F-S-D-V-C



fig.4.1

The most important elements of the front panel are:

1. Control panel
2. Operation panel
3. Handles or angle bracket for the 19" rack
4. Large surface earth connection

The controls on the front and rear panels are protected by the angle bracket (3).

For indications, the follow colours are generally used:

green	Power on
red	EMC Tests active
yellow	General signals

4.1.1 Control part

Control of the TRA3000 E-F-S-D-V-C is carried out by internal computer. The computer controls the EMC tests, stores the inputs of the numeric input terminal, updates the display, checks whether the inputs of the operators are valid values or not, stores the program and prepares test reports. The operator communicates with the TRA3000 E-F-S-D-V-C via the numeric input terminal, the display and the soft keys.

For better understanding, the control panel elements will be explained separately from the connection panel.

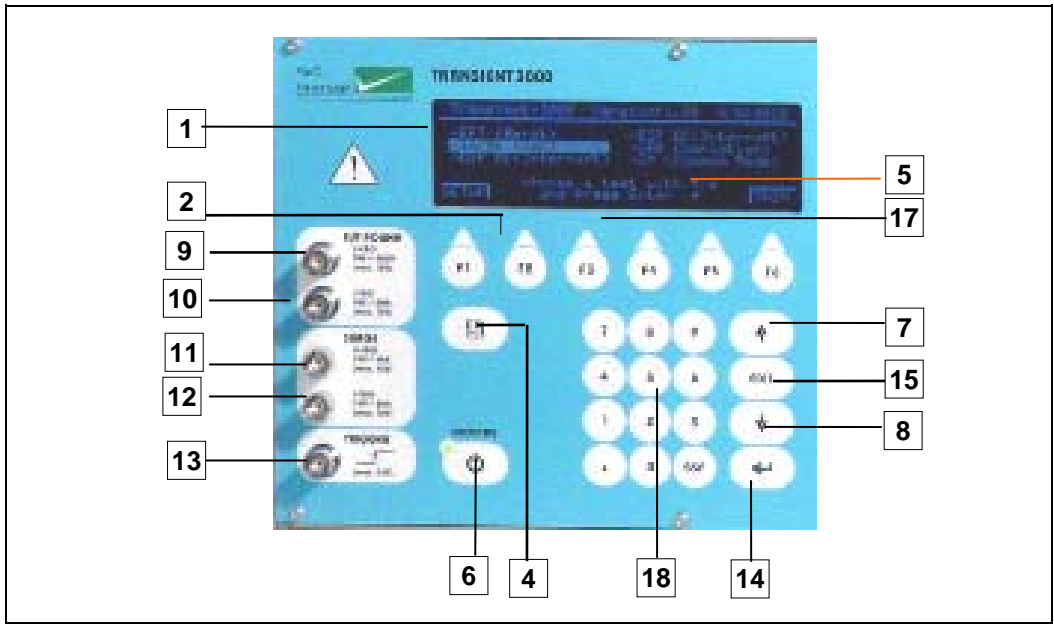

fig. 4.1.1

4.1.1.1 The Display (1)

All important information for the operator is permanently shown on the display during EMC testing. The large graphic display includes additionally 6 soft-keys and some hints or setting range information.

4.1.1.2 Soft-keys (2)

The program in the TRA3000 E-F-S-D-V-C is very complex, therefore six soft-keys are provided in order to be able to move and quickly change to different menus.

Example of "Main"

Test	Main	Ramp	Menu
Choice of tests	-pre-setting of nominal values -pre-set of coupling path	-definition of different ramps	-Power -EUT action if failed
EFT ESD SURGE DIP (Interruption) VAR. (Variation) MF (Magnetic field) CM (Common Mode)	e.g. EFT EFT V-peak. Polarity Repetition Burst Spike frequency HV-Out	e.g. EFT EFT V-peak Synchronisation Burst duration Spike Frequency	e.g. Power "ON /OFF" in ° Current limits Synchronisation Variac setting

4.1.1.3 Push button ON/STBY (6)

With this button, the TRA3000 E-F-S-D-V-C will be set into the power ON / OFF mode. In the turn off mode, the control and the signals are deactivated. In this status of the TRA3000 E-F-S-D-V-C, the power consumption is at a minimum of 5 W.

4.1.1.4 Push button up and down (7,8)

These two buttons make it possible to moves the cursor forwards or backwards through the menus.

4.1.1.5 Measuring outputs EUT Power Voltage (9) and Current (10)

A signal corresponding to the mains voltage is available at these two BNC outputs „EUT power“. Maximum 12 V for the voltage at the output (9) and maximum 12 V for the current at the output (10).

4.1.1.6 Measuring outputs SURGE Voltage (11) and Current (12)

During SURGE tests, voltage sequence of the SURGE waveform can be measured at the output socket (11) and the current sequence at output socket (12). The range and the accuracy of the measuring system is given in the Chapter 1.2 Technical data Section 1.2.8 measuring circuits, measuring outputs.

4.1.1.7 Trigger output for oscilloscope (13)

This output provides all the necessary trigger impulses for the different tests. The different trigger levels and the time delays are listed in Chapter 1.2 Technical data Section 1.2.9.

4.1.1.8 The Push-button ENTER (14)

Numeric values are changed only when the ENTER button is pressed.

4.1.1.9 Push-button Edit (15)

This button has a multifunctional use:

- Activate the dialogue line
- Open pull down windows

4.1.1.10 Buttons F1 to F6 (17)

The buttons F1 to F6 are allocated to the function as indicated on the display. Depending on the menu, different functions are allocated to the six buttons.

4.1.1.11 Numeric control panel (18)

If the cursor is activated in one line of the display, then data can be input with the numeric key board. Each data input must be terminated with ENTER.

The button BSP (Backspace) enables correction of an incorrect data input.

4.1.1.12 Dialogue line within the display (5)

Indicates what range can be selected or which next step must be done.

4.1.1.13 USB button (5)

All service date is stored to the USB stick when inserted into the rear panel “USB Port”

4.1.2 Operation panel

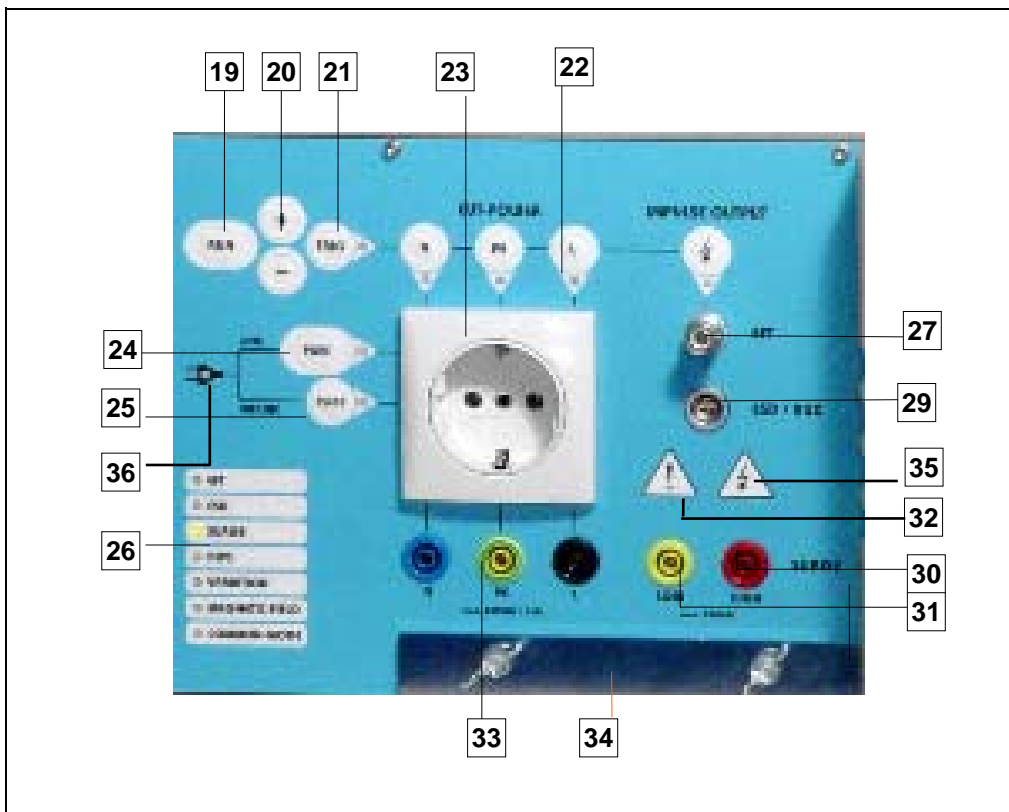

Fig. 4.1.2

4.1.2.1 Button Run (19)

With the „Run“ button, a test can be started or interrupted.

4.1.2.2 Manual Trigger (21)

When manual trigger is programmed and the tester is ready for manual trigger, this will be indicated by the LED. As soon as the signal occurs the pulse can be released by pressing the manual trigger button.

4.1.2.3 Signalling the EMC test type(26)

The LED (26) signals which of the seven possible EMC test is chosen: ESD, EFT, SURGE, DIPS, Variation, Magnetic field, Common Mode. A continuous signal indicates which test has been selected in set-up, while a blinking signal indicates that the test is running.

4.1.2.4 Indication of the coupling path (22)

The four LEDs indicate which path is receiving the disturbance . The three lines of the EUT power, or the direct high voltage outputs. The signals appear as soon as a test is active. With the buttons above the LED indicators, coupling path can be changed also during operation.

4.1.2.5 Single phase power output power plug Schuko(23) or banana plug (33) type.

When superposing the disturbance onto the EUT power line, the power cord of the EUT must be connected with the Socket (23). EMC PARTNER offers adapters for the different types of power cord connectors for different countries.

4.1.2.6 Button Power LINE PWR1 (24)

With this button the EUT power is turned on or off at the phase angle defined.

4.1.2.7 Button Variac (25)

With this button the EUT power is turned on from the variac. When the power of the EUT is feed from input (48) (see Figure 4.2) e.g. internal or external variac, this status will be indicated by the LED (25) .

4.1.2.8 Synchro ON EUT Power (36)

When a voltage higher than 30 V is applied at the EUT power 1 input on the rear side of the TRA3000 E-F-S-D-V-C, the synchronisation will be referred to the supply voltage. The LED (36) indicates whether the synchronisation is based on the EUT power voltage or not. At voltages lower than 30 V the synchronisation is based on the power line of the TRA3000 E-F-S-D-V-C (41). If the phase and the neutral are interchanged, no indication will occur.

4.1.2.9 High voltage pulse output EFT (27)

This output is needed to run EMC tests with the external capacitive coupling clamp or an additional coupling/de-coupling network.

4.1.2.10 Control plugs EXT-TRA3000 E (29)

This connector is for connecting the ESD discharge circuit accessory EXT-TRA3000 E. See TRA3000 E-F-S-D-V-C accessories.

4.1.2.11 Impulse output SURGE (30,31)

These two connectors are for connecting the SURGE coupling kit accessory or three phase coupling/de-coupling networks. See TRA3000 E-F-S-D-V-C accessories.

The outputs are marked with „high“ and „low“. The „low“ output is not earthed, and a maximum external voltage of 280 V ac can be connected, as described on the front panel.

4.1.2.12 High voltage (35)

Attention high voltage at the EFT BNC plug) and SURGE (MC plugs)

4.1.2.13 Earth connection (34)

Particularly for interference tests with high frequency components, such as EFT, a large surface earth connection is necessary. The earth terminal of the TRA3000 E-F-S-D-V-C allows a low inductance earth connection between test equipment and the reference ground plane to be made.

4.1.2.14 Attention, refer to manual (32)

This sign tells the operator to study the manual in detail. Only trained personnel are allowed to operate the TRA3000 E-F-S-D-V-C.

4.2 Rear Panel of the TRA3000 E-F-S-D-V-C

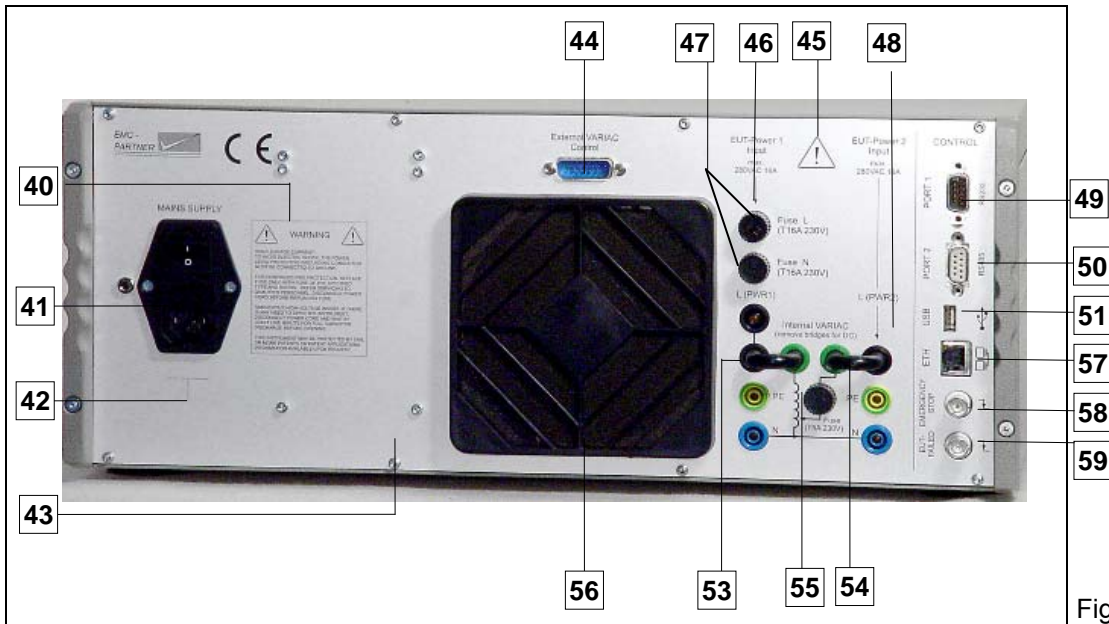

Fig. 4.2

4.2.1.1 Warnings (40)

High leakage currents. To avoid electric shock the power cord protective grounding conductor must be connected to ground.

For continued fire protection, replace fuse only with fuse of the specified type and rating. Refer servicing to qualified personnel. Disconnect power cord before replacing fuse.

Dangerous high-voltage inside. If there is any need to open the instrument, disconnect power cord and wait at least one minute for full capacitor discharge before opening.

This instrument may be protected by one or more patents or patent applications. Information available upon request.

4.2.1.2 Power supply of the TRA3000 E-F-S-D-V-C (41)

The TRA3000 E-F-S-D-V-C receives its power via power connection (41). A power switch, a fuse and a filter are built in directly at the mains plug.

Power consumption: turned on minimum < 20 W; maximum power consumption < 400 W, standby < 5 W
The fuse is rated with T 3.15 A / 250 V.

4.2.1.3 Type plate (42)

All important supply information is written on the type plate. Please quote the serial number and type of the equipment when requesting service or repair.

4.2.1.4 CE mark (43)

This plate is reserved for the CE mark. The CE -mark is needed for the free movement of the goods into and within the European community.

4.2.1.5 External Variac Control (44)

Via this special interface, the external variac can be controlled by the TRA3000 E-F-S-D-V-C. The external variac is needed for EUT (>12 A) and mains voltage variation (>5A).

4.2.1.6 Attention, refer to manual (45)

This expression requests the operator to consult the manual in detail. Only trained personnel are allowed to operate the TRA3000 E-F-S-D-V-C.

4.2.1.7 EUT Power 1; Inputs (46,47,53)

All input plugs and fuses for EUT power 1 are located in row (46). The two 16 A fuses for phase and neutral (47) located above. Below the fuses are the three power line connections for the EUT power supply (53). For the phase, two plugs are available for connecting the internal variac to the power. For external variac operation, the bridge (53) and (54) must be removed, see Chapter 6 „Testing with the TRA3000 E-F-S-D-V-C“.

Supply data: 0 to 260 V ac; 0 to 110 V dc; 16 A.

4.2.1.8 Internal Variac (54,54)

For the interruption and variation mode tests different voltages are needed. As standard the TRA3000 E-F-S-D-V-C has an internal variac with a continuous current rating of 6 A. At shipment, two bridges are inserted (53) and (54). The variac is protected with its own fuses. For external variac operation, the two bridges must be removed, see Chapter 6 „Testing with the TRA3000 E-F-S-D-V-C“.

4.2.1.9 EUT Power 2 Inputs (48)

Input for the disturbance level during interruption. When an external source, e.g. external variac or an external ac/dc source (PS3), is used, the external source must be connected to these inputs (48).

Supply data: 0 to 260 V ac; 0 to 110 V dc; 16 A.

4.2.1.10 Interface „Port 1“ RS232 for controller PC (49)

The RS232 interface port can be used to control the TRA3000 E-F-S-D-V-C using an external PC with customized program. To configure the interface, see Chapter 13 „Remote Control“.

4.2.1.11 Interface „Port 2“ RS 485 for controlling external coupling networks or checking the EUT failed status (50)

Via this interface, the coupling path of external CDNs can be controlled.

For further information, see the specific CDN manual.

With an additional EMC PARTNER module, a multiple channel EUT-failed control can be built. The control system operates during the EMC tests.

4.2.1.12 The USB Port (51)

Via this interface, the service data can be stored on a USB stick. In case of failure the data can be sent via Email to EMC PARTNER for analysis.

4.2.1.13 Forced cooling of the TRA3000 E-F-S-D-V-C (56)

A ventilator cools the TRA3000 E-F-S-D-V-C internally. Forced cooling is necessary for the impulse forming network devices and the electronic high-voltage switch. A distance of about 20 cm must be maintained between the rear panel of the TRANSIENT 3000 and any wall, and about 3 cm between the sides of the TRA3000 E-F-S-D-V-C and any equipment or wall. The TRA3000 E-F-S-D-V-C can be built into a 19" rack, with 3 cm side separation.

4.2.1.14 Ethernet remote control (57)

The Ethernet interface port can be used to control the TRA3000 E-F-S-D-V-C using an external PC with GENECS program. To configure the interface, see Chapter 13 „Remote Control“.

4.2.1.15 Emergency stop, (EMERGENCY STOP) (58)

When the „emergency stop“ input is activated, the EMC test and the EUT power supply will be immediately interrupted. The power supply of the TRA3000 E-F-S-D-V-C will not be turned off. The status „emergency stop“- will be indicated on the front panel. Emergency stop corresponds to 0V at the input.

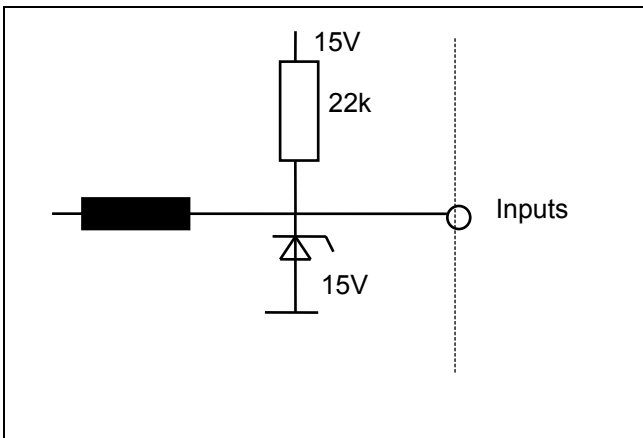

The trigger value at the input is approximately 3V
 Low: active
 High: inactive
 Driving with an open-collector output is recommended.

4.2.12 Definition of the inputs „Emergency stop and EUT failed“

4.2.1.16 EUT Failed input (59)

This input can be used for a single channel EUT passed/failed detection during the EMC test. EUT failed is equal to 0V.

5 Preparation for Operation

5.1 Attention, Refer to Manual

This manual is an integral part of the TRA3000 E-F-S-D-V-C. The safety rules and precautions in the manual must be observed. EMC PARTNER and their representatives accept no responsibility for damages to persons and equipment as a result of non-observation of the safety rules and precautions in this manual.

Before connecting the TRA3000 E-F-S-D-V-C to a public power line, Chapter 3 „Safety must be carefully studied.

5.2 Operators and Service Personnel

Only trained personnel should carry out EMC tests. For small groups of maximum 10 persons EMC PARTNER AG offers the following in-house seminars in English or German:

1. EMV Introduction
2. EMV Standardisation
3. EMC „ESD“ immunity test
4. EMC „EFT“ immunity test
5. EMC „SURGE“ immunity test
6. EMC „DIPS“ immunity test
7. EMC „HARMONICS“ immunity test
8. EMC „MAGNETIC FIELD“ immunity test
9. EMC „CW CURRENT INJECTION“ immunity test
10. EMC „CE-MARK“ transient immunity tests
11. „NEMP“ immunity test
12. „AC, DC, IMPULSE“ insulation test

5.3 Checks before operation

5.3.1 Optical verification of the TRA3000 E-F-S-D-V-C

Before you unpack the TRA3000 E-F-S-D-V-C, please check whether the packing is deformed or damaged. When the TRANSIENT is unpacked, also check whether the tester is damaged. If you detect a damage, please inform EMC PARTNER and the shipping organisation immediately.

5.3.2 Power source check

On the rear panel, you will find a type plate. Please check whether the Tester has been prepared for the correct power line voltage of your public power. If the power supply voltage is different please inform EMC PARTNER AG in Switzerland, or your EMC PARTNER AG representatives.

5.3.3 Connecting the TRA3000 E-F-S-D-V-C to the power line

Please use the supplied power cord for connecting the TRA3000 E-F-S-D-V-C to your public power supply. As stated on the rear panel, the power supply must have an earth safety wire. Please check the earth connection on your power outlet before you connect and turn on the TRA3000 E-F-S-D-V-C.

5.3.4 EUT Power, Power source for the EUT

To connect the EUT Power 1 Input with the public power supply please cut the three black, blue and green/yellow cables supplied into two halves of the same length. One half used for the EUT Power 1 connection on the rear side of the TRA3000 E-F-S-D-V-C, and the other half for supplying the EUT from the front panel. The high inrush current during the DIPS test can only be reached, when the public power supply can deliver 500 A peak current. The public power supply must be protected by 16 A fuse.

Connection of the internal Variac:

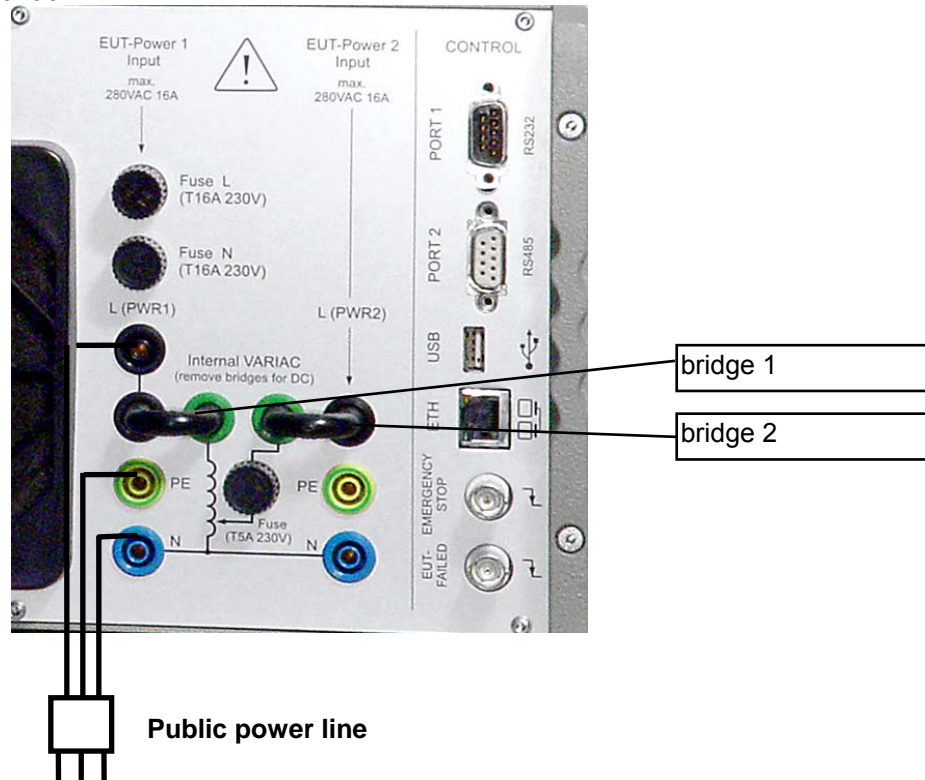

The Bridge 1 connects the internal variac with the public power supply on the primary side.

The Bridge 2 connects the secondary side of the variac to the EUT power 2 input.

Attention: Phase and neutral must be connected correctly. When the phase and the neutral are connected correctly, this is indicated on the front panel by a green LED.



Attention!

If your power supply is equipped with fault current protective switch it may release when connecting the TRA3000 E-F-S-D-V-C. The TRA3000 E-F-S-D-V-C contains filters with a leakage current to earth. In addition a high current will flow to earth when Surges are superimposed between phase and earth. The impedance of 2 Ohm in series with 10 Ohm and 9 µF is a load on the power supply.

Solutions:

1. For testing with TRA3000 E-F-S-D-V-C use a power supply without a fault current protective switch.
2. Connect an insulation transformer between power supply and TRA3000 E-F-S-D-V-C. One secondary output terminal of the transformer must be grounded.

As a results of the leakage current always connect two earth leads to the TRA3000 E-F-S-D-V-C. The TRA3000 E-F-S-D-V-C has four earth terminals.

5.3.5 EUT Power, supply of the EUT with voltages differ from the public power line (Variac)

Internal Variac

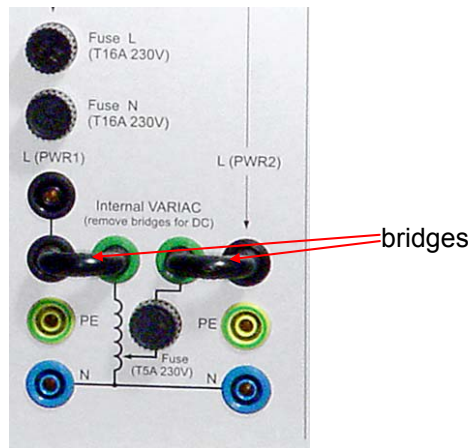

Both bridges must be placed as shown in the picture . EUT Power 1 must be connected to the 230 V public power supply.

Figure 5.3.5.1

Connection external Variac:



EUT
Power 1

EUT
Power 2

The external Variac replaces the internal Variac.

Remove the two bridges.
EUT Power 1 (L1) of the TRA3000 E-F-S-D-V-C must be connected with L1 of the external Variac.
EUT Power 2 L, N, PE must be connected as shown on the picture.

In addition connect the control cable between „External Variac Control“

Figure 5.3.5.2

Accessories delivered with the external Variac

- See VAREXT1000 user manual

5.3.6 EUT Power, supply of the EUT with dc



bridges

Caution!



Before a dc supply for the EUT can be used the two bridges must be removed.

If the bridges are not removed when the EUT is powered with dc the internal Variac will be heated and destroyed.
 Dc voltage range 110 V
 Maximum dc current 16 A

Figure 5.3.6

Preparations:

1. Remove the two bridges on the rear side of the TRA3000 E-F-S-D-V-C.
2. Connect the DC power supply with EUT - Power 1. Whenever possible connect the positive pin of the dc source with L and the negative pin with PE. Only when a grounding of the EUT is no allowed connect the negative pin with the neutral N of the TRA3000 E-F-S-D-V-C.
3. When a dc-dips to x% of Udc is required a second dc source must be connected to EUT power 2 of the TRANSIENT. When a interruption of the dc-source to 0% of the Udc must be applied, connect L2 with N of EUT power 2.

Preparations:

Activate "Main" DIPS test and select the d.c. interruption mode.

Remarks:

- The green LED „Synchro on EUT Power“ has no indication.
- The voltage and current measurement EUT Power is inactive. The measurement circuit is designed for ac only.

SURGE superimposing on dc

For this kind of test the dc voltage should be, if possible, connected to L and PE on EUT-Power 1. Only for this coupling path the coupling impedance is 10 Ω and 9 μF .

This is an advice from EMCP based on experience of customers, where protection devices have been destroyed when SURGE tests have been carried out with coupling impedance 18 μF and 2 Ohm between L and N. In the real installation environment they never had a damage of the equal protection devices. In the IEC 61000-4-5 no specific chapter deals with different d.c. sources. The only hints for Surge tests on d.c. supply can be found in the single phase test set up examples.

5.4 Hints for the test set up according to IEC standards

We list below those experiences of EMC PARTNER which are important for the success of the various tests. This information is only partly given in the standards.

Before a test is started, it is important to define which ports (inputs, outputs) must be tested. For the most important transient tests the ports are given as follows in the European generic standard:

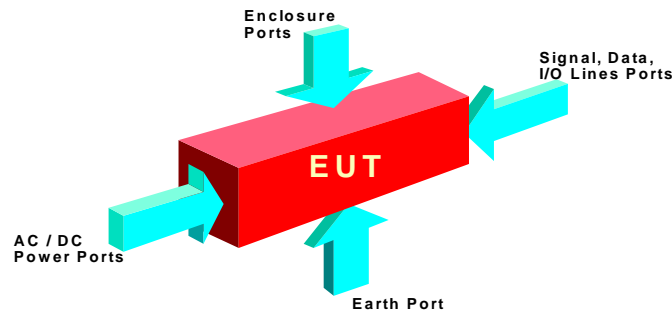

figure 5.4

5.4.1 Test set up EFT

Ports which must be tested:

AC/DC power supply, signal, data and I/O lines;

Coupling path:

For EFT pulses, the capacitive coupling is the dominant coupling path. The reasons why the capacitance coupling path play a dominant role are explained in the book „EMV Störfestigkeitsprüfungen“, published by FranzisVerlag Munich, or in the report „Schmalbandige Störfestigkeitsprüfungen im n-Sekunden Bereich“ by M. Lutz.

An example will show, that the impedance of EFT spikes at a capacitance of 100 pF (e.g. stray capacitance can be as high as 100 pF) is very low. As an approximation, the rise time of 5 ns can be converted into a frequency of 100 MHz, and the impedance can be calculated as:

$$Z = 1 / 2\pi f C = 1 / 6,28 \times 100 \times 10^6 \times 100 \times 10^{-9} = 15 \text{ m}\Omega$$

Test set-up:

As shown in the mathematical example, stray capacitance between coupling plate, tester, cables, laboratory wall and reference ground plates can have a large influence on the test results. Here are some hints for the set up of an EFT test:

- The tester must remain on the reference ground plane, and be connected to the reference ground plane by a low inductive connection.
- On table-top equipment tests, it is not clear from the existing IEC basic documents 61000-4-4 that the reference ground plane must be on the table, and not on the floor under the table. The EUT must be lifted 10 cm from the reference ground
- All cables must be placed in a reproducible manner. (We recommend a photo of the test set-up)

Safety:

The burst impulses described in the IEC standard 61000-4-4 are not dangerous to persons, because the energy and the pulse duration are too low. Testers are available on the market with higher spike frequencies and longer test duration, where the energy is much higher, and therefore more dangerous to persons.

As mentioned in Chapter 2, EFT disturbances can affect heart pacemakers or hearing aids.

5.4.2 ESD test set up

Ports which must be tested:

Enclosure Ports include operational keys, displays, ground and earth points, metallic parts such as connectors etc.

Coupling path:

Basically all types of coupling exist during static discharges. Practical experience shows that, for most electronic equipment, the current is the dominant parameter.

In practice the path of the discharge current plays an important role e.g. if secondary sparks or breakdown in the EUT occur the test is no longer reproducible.

The frequencies contained in the ESD discharge current are higher than in the EFT spike impulse. As a consequence, reproducibility of the ESD test is more difficult than the reproducibility of the EFT test results. The ESD test is a most complex transient test.

Test set-up:

As shown by the example in the IEC document 61000-4-2 the same test set up can be used for all different discharge modes (contact-, air- and indirect-discharge). Under the table lays the reference ground plan and on the horizontal coupling plane is placed on the table.

The test mode used depends on the test object.

The three different kinds of test object are:

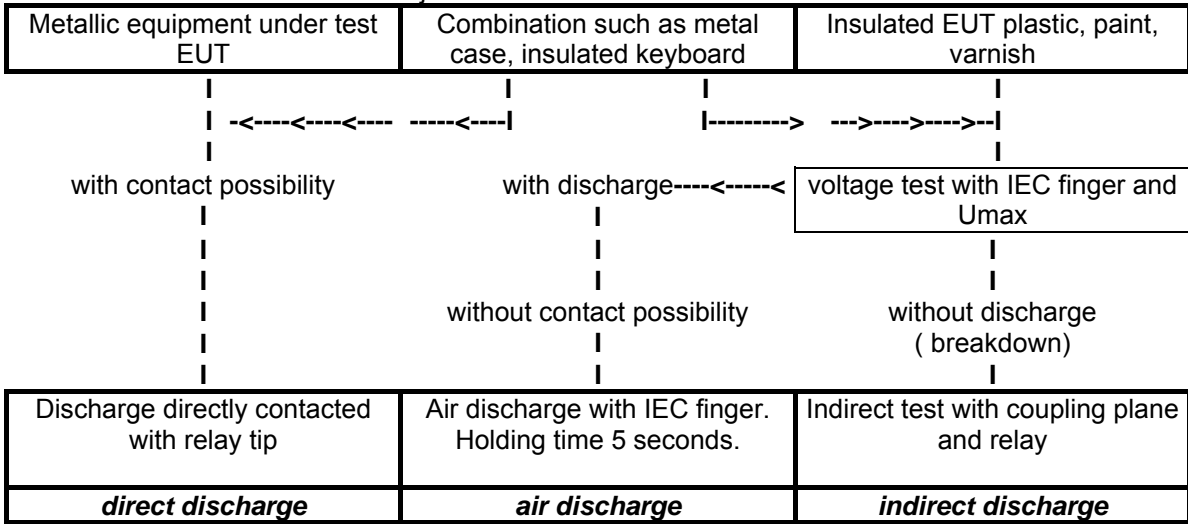

The ESD transient test is a single event test. The susceptibility of an EUT is strongly influenced by the clock frequency. With the clock frequency, the information will be transmitted in the EUT or to the auxiliary equipment within a system. The ESD pulse enters the EUT when no information is being transmitted, the EUT has a very good immunity to EMC test, whereas the equipment will fail in operation. The existing ESD testers on the market the discharge cannot be synchronised with the clock frequency. Therefore the number of shots must be increased up to 100 discharges.

Safety:

ESD discharges are not dangerous for humans.

5.4.3 Test set up SURGE

Ports which must be tested:

AC/DC power supply, signal, data and I/O lines; earth connections

Coupling path:

Unlike the EFT and ESD tests stray capacitance are not important here. The frequencies contained in the SURGE impulses are lower. The galvanic and mutual coupling are dominant. The cable lay-out and the test set-up is therefore uncritical. The test results are easily reproduced.

Test set-up:

What must be tested?

Protection circuit for inputs, and outputs as shown in the figure below.

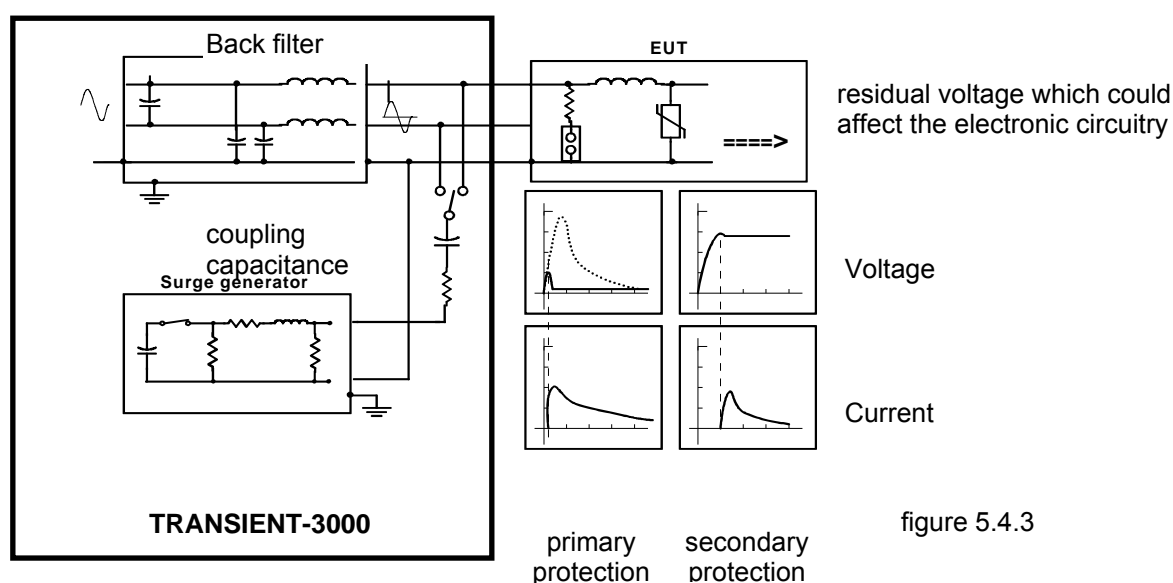

figure 5.4.3

Superimposing SURGE pulses onto power lines is carried out using a capacitance between the tester and the power line. With the SURGE test, the effectiveness of the protection circuit will be tested. The residual voltage after the protection circuit could affect the electronic parts of the EUT.

The SURGE test is a single discharge, as for ESD. The considerations regarding single discharge which were made for the ESD discharge also apply here. Synchronisation with the power line frequency is important, and must be considered.

With the proposed current injection method, the bonding of screen and earth connections can be tested.



Safety:

The SURGE pulses can be dangerous for persons. The EUT and its cables should not be touched during SURGE EMC tests.

In case of a breakdown in the EUT, it must be remembered that high currents can flow from the power supply.

Test set up DIPS, Interruption

Ports which must be tested:

AC / DC power supply

Coupling path:

These disturbances appear on the power lines. Disturbance sources are short circuits between power lines, power line switching actions and heavy load changes etc.

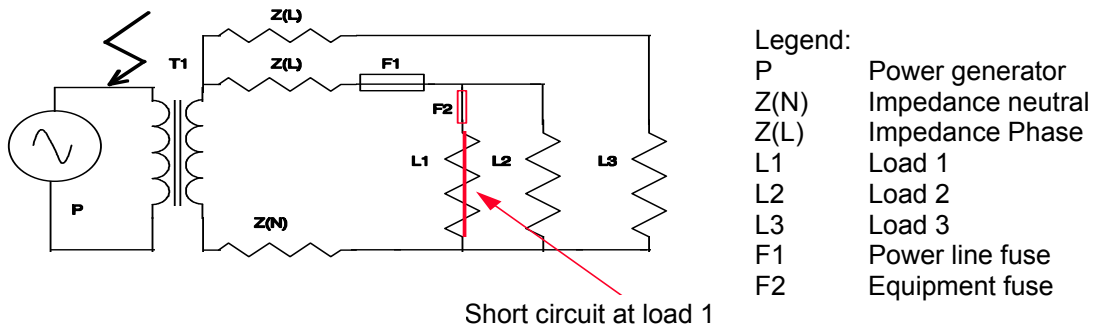

figure 5.4.4.1

Test set-up:

- During DIPS test remember that high inrush currents are possible during the turn on phase of the DIPS.
- With switched power supplies the current can increase linearly with the voltage reduction e.g. I= 1A at U 230V, and with reduced voltage of U = 40%, the current increases to 2,5 A.
- For a realistic DIPS and interruption test, the test object must be discharged using the power line impedance, see Chapter 3.4.

Test levels, Voltage interruption

Test Level % U_T	Voltage Dip/int % U_T	Duration (in period)
0	100	0.5* 5 10
40	60	25 50
70	30	x

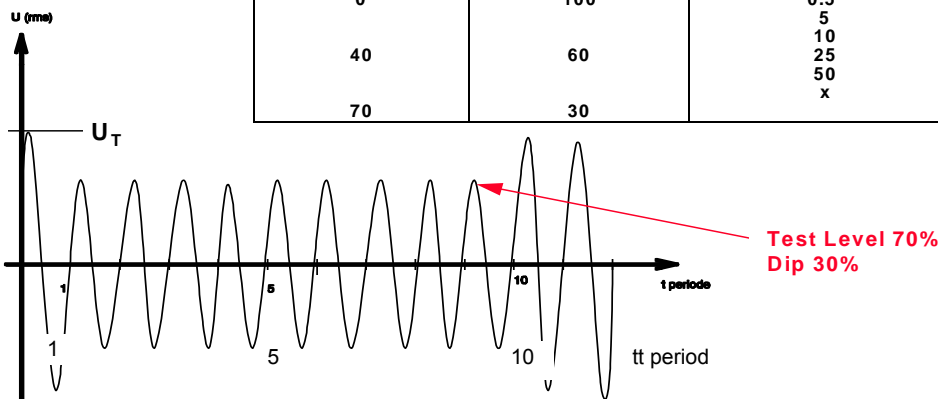

figure 5.4.4.2

Begin of the interruption

End of the interruption

5.4.4 Test set-up for table top equipment

Test set up

Single Phase EUT

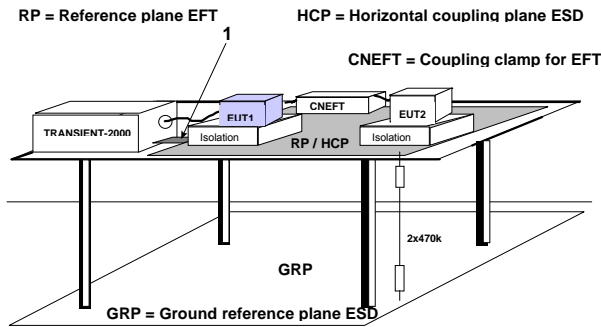

Three Phase EUT

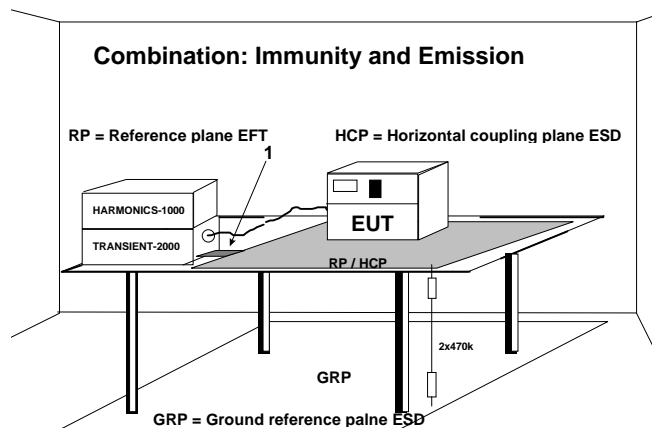
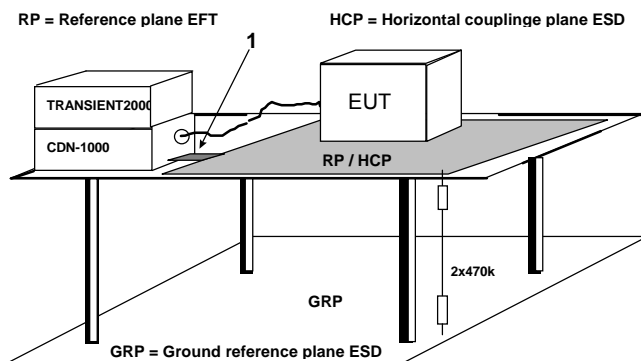

Test sequence

I. EFT

1. Connect the earth bar of the TRA3000 E-F-S-D-V-C with the flat multiwire cable (1) to the reference ground plate
2. Put 10 cm insulation between EUT and the reference ground plate
3. Carry out the tests!

II. ESD

1. Remove the flat multiwire cable (1) between the earth bar of the TRA3000 E-F-S-D-V-C and the reference ground plate
2. Put 0,5 mm insulation between EUT and the reference ground plate
3. Carry out the tests!

III. SURGE, DIPS, VARIATION

1. Reinstall the flat multiwire cable 1
2. Carry out the tests!

I. EFT

1. As for single phase EUT
2. As for single phase EUT
3. Connect the Impulse out of the TRANSIENT with EFT coupling on the threephase Coupling/De-coupling network CDN-2000-06-32
4. Carry out the tests!

II. ESD

1. As for single phase EUT
2. As for single phase EUT
3. Carry out the tests!

III. SURGE,

1. Make connection 1
2. Connect the surged phase for synchronisation with EUT Power 1
3. Carry out the tests!

IV. DIPS Interruption

1. Loop the phase for dips and interruption through the TRA3000 E-F-S-D-V-C (EUT Power 1)
2. Carry out the tests!

I. TRA3000 E-F-S-D-V-C Tests:

1. Carry out the tests as explained for single and three phase EUT

II. HARMONICS-1000-Measurements

1. Harmonics in accordance with IEC 61000-3-2
2. Flicker in accordance with IEC 61000-3-3
3. Immunity Harmonics IEC 61000-4-13

For brochures and further information about HARMONICS-1000 contact EMC PARTNER AG or your nearest representative.

5.5 Practical testing sequence

In practice, the following test procedures has been shown to be reliable:

1. Burst-Testing:

- **Burst-testing** on mains inputs with a test voltage of 4kV
- **Burst-testing** of signal and data lines up to 4kV

The energy contained in the burst pulses is relatively small, thereby minimising damage to the test object. The higher the repetition frequency, the more likely that weak points become evident in the test object.

2. ESD-Testing:

With this test, effects induced through the keys and the housing of electronic equipment can be simulated.

Metallic parts, contacted method up to 8 kV

- Insulated parts, air discharge up to 15 kV

In practice, an item that has undergone burst testing shows a better immunity to ESD, than one which has not. Likewise, an item that has undergone burst testing shows a better immunity to current injection or cw field tests.

3. Surge-testing:

- **Surge testing** mains up to 2 kV

This should be used to test input protection elements and protection circuits installed in electronic equipment. The energy content is very high in the surge test, and can destroy elements in the EUT.

- **Surge testing** signal and data lines up to 1 kV

4. Mains simulation:

As a consequence of the increasing number of non-linear loads, the quality of the mains gets worse and worse. To be sure that electronic equipment can withstand the mains interference, test are such as:

Mains interruption, Mains under and over voltage variation, harmonics simulation etc. are required.

5. Further testing:

For most EUTs, the described transient tests are sufficient. Further testing of the product to determine differences, e.g. with regards to the effects of magnetic field on monitors or on protection elements, may be needed.

Conclusion:

The product determines which kind of EMC test must be applied. It is also important, that EMC testing should only be carried out by trained personnel, with a knowledge of how the test object should function, and some knowledge of transients and EMC. The four tests, with their range of impulse types, simulate only single signals, and do not cover the complete range of EMP phenomena. However, if no more failures were registered, after a period of EMC testing with electronic equipment and systems in practical operation, it would not be justified to impose additional EMC tests.

Further EMC test information can be obtained from EMC Partner or from our representatives.

6 Testing with the TRA3000 E-F-S-D-V-C

6.1 Quick start of the TRA3000 E-F-S-D-V-C

Only when Chapter 2 „Safety“ and Chapter 5 „Preparation for operation“ and all instructions have been followed can TRA3000 be operated. A quick start includes the most important tests using the TRA3000 E-F-S-D-V-C.

EMC PARTNER store the needed tests specified in the generic standard "domestic" in the TRANSIENT 3000 before shipping.

To start a set-up, the following steps must be carried out:

- Turn the power switch on the rear side to position I
- Operate the ON/STBY button on the front panel the display turns to:

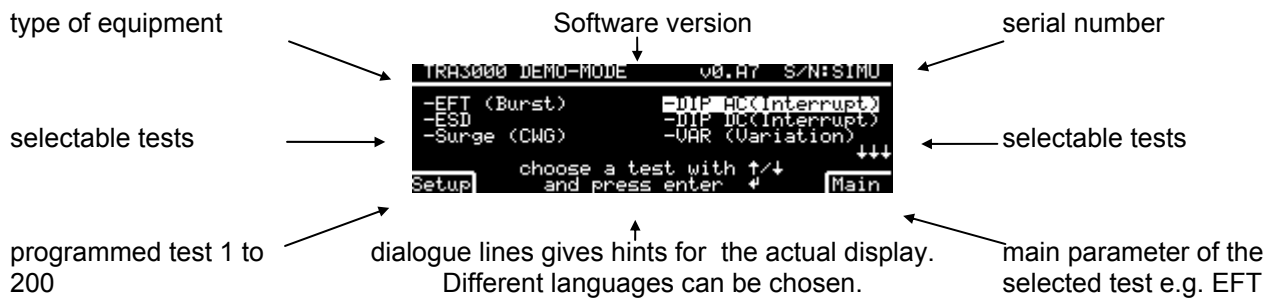

Press "SETUP"

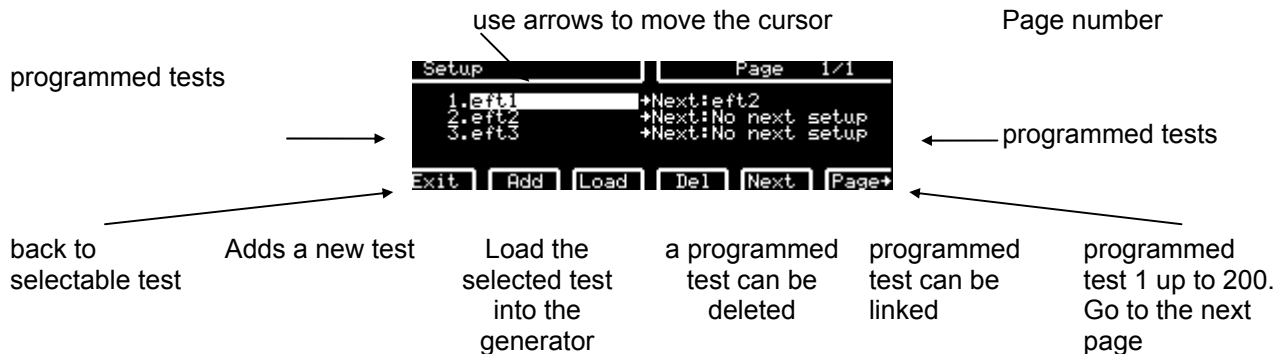

Quick test example AC EFT +1kV:

- move the cursor with the arrow to number 3
- press F2 Load

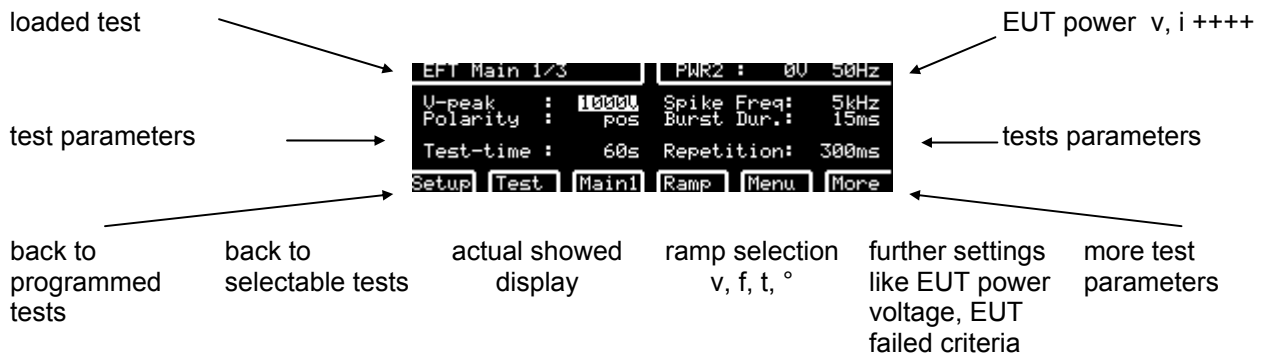

- press "RUN" button

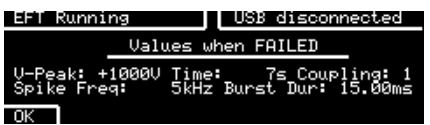
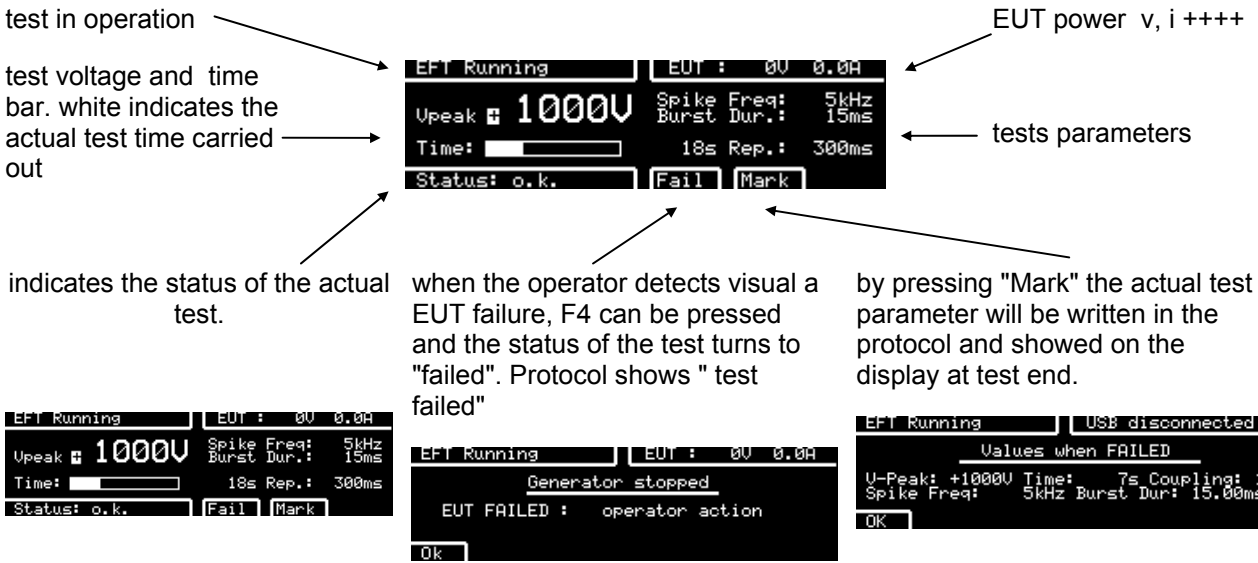

When in OPTIONS –Preferences- Default Path for Protocol the Web server is selected the protocol will be shown as an html document.

Test Company :		26-02-2010	
Test Operator :		Date :	
Generator Information :		EUT Information :	
Device :	TRA 3000	Description :	
Serial Number :	SIMU	Serial Number :	
Firmware version :	0A7	Comments :	
Environment :			
Temperature :	20°	Relative Humidity :	40%
Test setup :		EFT (Burst)	
V-peak :	1000V	Spike Frequency :	5kHz
Polarity :	pos	Burst duration :	15.00ms
Trigger :	auto	Repetition :	300ms
Synro :	on	Random Spikes :	off
Synro Angle :	0°		
Coupling : Impulse-Out			
Ramp kind : No ramp			
Pwr1 :	230V 50Hz	PowerON synro :	0°
Pwr2 :	0V 50Hz	PowerOFF synro :	0°
Current Limit : 16A			
Simulation - Demo mode with Genecs			
Start time :	10:55:44	Stop time :	10:55:58
Test Results :	FAILED		
Test-Time :	80s		
Actions	Time	V-Peak	Spike Freq Burst Dur. Synro
1. Coupling EFT to: Impulse-Out			
EUT failed !!	8s	+1000V	5kHz 15.00ms 0°
Test End :	10s	Result :	Test aborted

Well that's easy isn't it ?

All other programmed tests can be started and carried out in the same way. All test can be started or stopped with the "RUN" button.

The quick-start tests contain only a small part of the testing possibilities of the TRA3000 E-F-S-D-V-C. In the next two sections, the additional possibilities of the TRA3000 E-F-S-D-V-C will be explained in detail.

6.1.1 Selection of a language: Deutsch, François, Italian, Espagnol and Beep function

One of the great advantages of the TRA3000 E-F-S-D-V-C is the language selection. The equipment is shipped with English language selected. To change the language follow the instructions below.

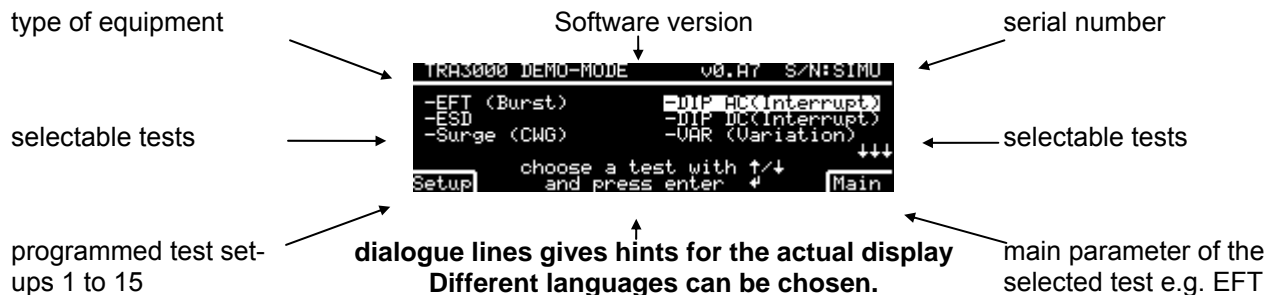

Press "Main" - and twice "Menu" - "UTIL" - -EDIT button



display when "Main" has been pressed
 display after pressing twice Menu and UTIL Turn the beep function "ON" or "OFF" as personally preferred..
 after pressing "EDIT" button

Choose the desired language (e.g. German) with the arrows and quit with the ENTER button and press soft key F2 "TEST". The display "TEST" has now changed to

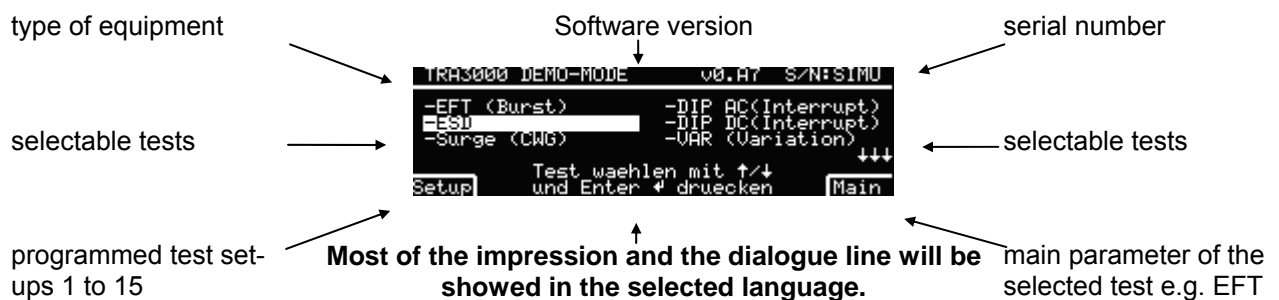

Further languages are possible on the GENECS software.

Advantage:

Automatically all expression and remarks on the display and the **protocol** will be written in german or in the selected language.

6.1.2 Protocol possibilities

The TRA3000 E-F-S-D-V-C can be adapted to printer with serial or Centronics ports. The TRA3000 E-F-S-D-V-C default value are set at shipment: Autoprint ON, Port Centronics, Beep on Trig ON, Beep on Fail ON. The default values can be changed as follow:

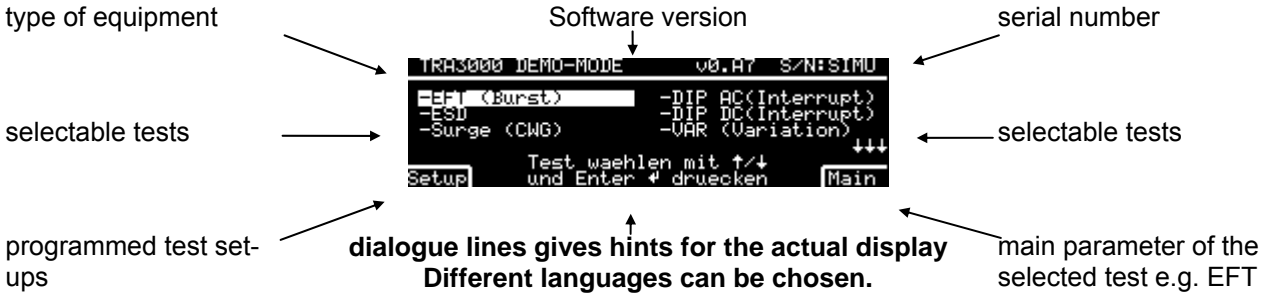

Press "Main" - and twice "Menu" - "PROT"

<p>display when "Main" has been pressed</p>	<p>display after pressing twice Menu</p>	<p>after pressing "PROT." soft key</p>
---	--	--

<p>display when "EDIT" has been pressed</p>	<p>Like on mobile phones company name can be written</p>	<p>On the same way the operator name can be written</p>
---	--	---

Get protocol data from USB: no

Get protocol data from USB: no

Get protocol data from USB: no

Testfile and logo

Two possibility exist to print out the protocol:

USB stick

1. Insert on the rear panel a USB stick.
2. Press the USB button on the front panel
3. Transfer the html document with the USB Stick to a PC
4. Print the protocol from the PC

GENECS Software

Print the html document directly from the PC





6.1.3 EUT - Power and EUT - Control

For running the interruption, voltage variation and DIPS, the EUT Power 1 Input on the rear side of the TRA3000 E-F-S-D-V-C must be connected to the mains. The mains is correctly connected if the green LED in the symbolic power plug on the front panel of the TRA3000 E-F-S-D-V-C is glowing. The green indication will only be visible when the phase and the neutral are connected in the right sequence. If the power main is connected and the green light is not on, the mains cable phase and neutral must be interchanged. This ensures that L and N as written on the front panel correspond with the phase and neutral of the mains.

Input power N> 50V and L-N <N	Generator malfunction No synchronisation signal
Message when N and L are interchanged. Please change L and N	Message when no PWR1 is connected and SURGE test is selected

Different parameter of the EUT power can be selected:

Press "Main" - and once "Menu" - "POWER"

			
Setup Test Main1 Ramp Menu More		Setup Test Main1 Ramp Menu Main1	Please select PWR1 source

display when "Main" has been pressed and "Power."

Power Main



The angle turning "on" the EUT power synchronised to the EUT power input of the TRA3000 E-F-S-D-V-C in degrees. With this feature inrush current of EUT can be checked. The measurement of the current can be made via EUT-Power I-CRO on the front plate on an oscilloscope.

Power No:

This setting must be selected when d.c is applied to the PWR input.

Power PS3:

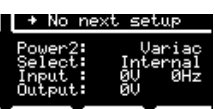
With this setting the PS3 power can be controlled from TRA3000. The PS3 allows to supply the EUT via the TRA3000 with different power voltage and frequencies.

			
Setup Test Main1 Ramp Menu Main1		Please select PS3 output mode	Please select PWR2 source

display when "PS3" has been selected With voltage the power and Frequency of the PS3 can be selected. Display when power2 "Edit" has been pressed

Variac voltage:

When the variac with button PWR2 is activated the output voltage can be changed directly by editing the output voltage. Online the power voltage is measured and indicated on top of the display.

Current Lim.:

When the EUT supply current will reach the selected limit the test will be stopped and the EUT power will be turned OFF. The current limiter can be used for automated test during night etc. The reaction time of the limiter is several 100 ms. During a variac regulation, or while printing a report the current limiter is inactive.

6.2 Editing test parameters

In addition to the installed test 1 to 15 of EMC PARTNER AG, you can also write your own test. In the following sections, the menu which you need to define your own test will be described.

The sequence of the menu presentation corresponds with the soft key button:

Test, Main, Ramp, Menu.

The installed tests can be edited or deleted.

6.2.1 Overview of programmable test with the TRA3000 E-F-S-D-V-C

Press F1 SETUP the display changes as follow:

one Setup consist of up to 200 tests

display when "Add" and "Edit" has been pressed.

display when "Del" has been pressed.

after pressing "Next" the test highlighted with the white cursor ask will be linked.

Test name could be written with the GENES windows above of with the keyboard of the PC. See chapter GENECS software.

On the next few pages the possible tests of the TRA3000 E-F-S-D-V-C are summarised. Some of the EMC test can only be carried out when the accessories are available.

6.2.1.1 ESD

```

ESD Main 1/2      ED1 : 00 0.0A
U-charge : 4000V  Discharge: Air
Polarity : pos    Repetition: 1s
No Pulses : 100  Pulse Counter:
                          Every Pulse
Setup Test Main1 Ramp Menu More
    
```

IEC 61000-4-2

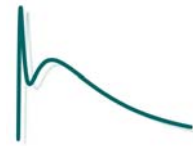

6.2.1.2 EFT

```

EFT Main 1/3      PRK1 : 230V 50Hz
U-peak : 1000V   Spike Freq: 5kHz
Polarity : pos   Burst Dur.: 15ms
Test-time : 60s  Repetition: 300ms
Setup Test Main1 Ramp Menu More
    
```

IEC 61000-4-4

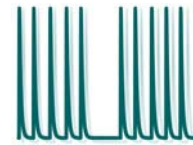

6.2.1.3 SURGE

```

Surge Main 1/3    ED1 : 00 0.0A
U-Peak : 1000V   Waveform : CWG
Polarity : pos   Repetition: 5s
No Pulses : 10
Setup Test Main1 Ramp Menu More
    
```

IEC 61000-4-5



6.2.1.4 Magnetic Field "a.c"

```

MF - AC Main 1/1  ED1 : 00 0.0A
MF Level : 30A/m  Antenn MF-1000-1
Test-time : 60s  Select MF-1000-2
                          MF-1000-3
                          special
Select MF-antenna type
    
```

IEC 61000-4-8

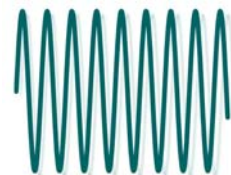

The magnetic field can be selected in A/m. Three antenna types can be selected.

6.2.1.5 Magnetic Field "SURGE"

```

Surge Main 1/3    PRK1 : 230V 50Hz
U-Peak : 1000V   Waveform : CWG
Polarity : pos   Repetition: MF-1
No Pulses : 10   MF-2
Waveform of pulse
    
```

IEC 61000-4-9



The magnetic field can be selected in A/m. Two antenna types can be selected.

6.2.1.6 Interruption

```

DIP Main 1/4      PRK1 : 230V 50Hz
DIP Level : 70%  Mode: > i Period
Test-time : 60s  Duration: 210ms
Repetition: 3s
Setup Test Main1 Ramp Menu More
    
```

IEC 61000-4-11



6.2.1.7 Variation

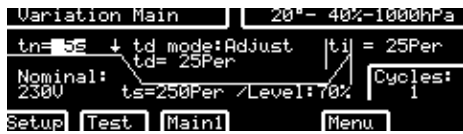

IEC 61000-4-11 Ed.1

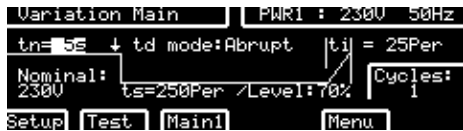

IEC 61000-4-11 Ed.2

6.2.1.8 Common Mode



IEC 61000-4-16



6.2.1.9 Interruption on d.c.

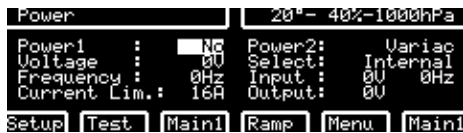

IEC 61000-4-29

6.2.1.10 Power from Variac with superimposed EFT or SURGE



IEC 61000-4-4
IEC 61000-4-5

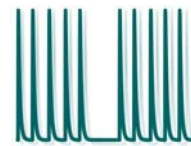

When the cursor is placed as shown the EUT power voltage can be selected and the EFT or SURGE superimposed at the chosen supply voltage.

6.2.2 Nominal values setting

When in the display „TEST“ e. g. the EFT test has been chosen and the „Main“ button has been pressed, the different parameters of the „Electric Fast Transient test“ can be edited.

The parameter values can only be selected within the range given. If values are chosen that are above or below the given range the maximum or minimum value will be input automatically.

6.2.2.1 Editing EFT test parameters



When the EDIT button has been pressed the dialogue line indicates the possible range like v, f, time, etc.

The values can be varied as follows within the given ranges:

1. Set the cursor to the parameter for editing
2. Edit the values as required using the numerical keys
3. Confirm that the values entered are correct by pressing the ENTER - button.

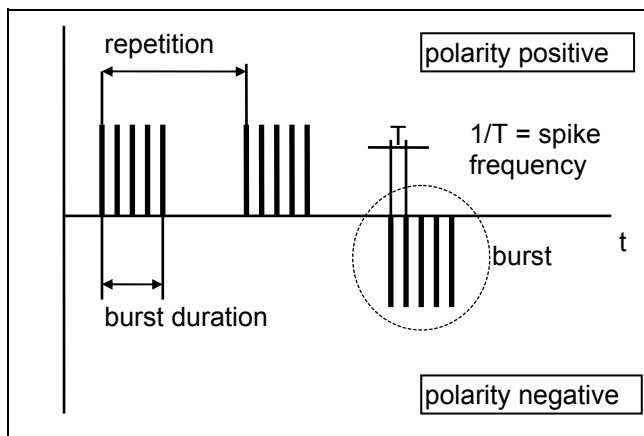

6.2.2.1.1 definition of EFT parameters

The *Repetition*, *Burst Duration* and *Spike Frequency* are combined in the number of spikes / seconds value (Spike Rate):

$$\text{Spike rate [Spikes/s]} = (\text{Burst duration [ms]} / \text{repetition [ms]}) \times \text{spike frequency [kHz]} \times 1000$$

This formula is only valid if the „*Burst Duration*“ is lower than the „*Repetition*“. If the „*Burst Duration*“ is equal the „*Repetition*“, the „*Spike Rate*“ will be equal to the „*Spike Frequency*“ (continuous burst).

$$\text{Spikes per Burst} = \text{Burst duration [ms]} \times \text{Spike frequency [kHz]}$$

The following Spike Rate Limits are valid for the TRA3000 E-F-S-D-V-C:

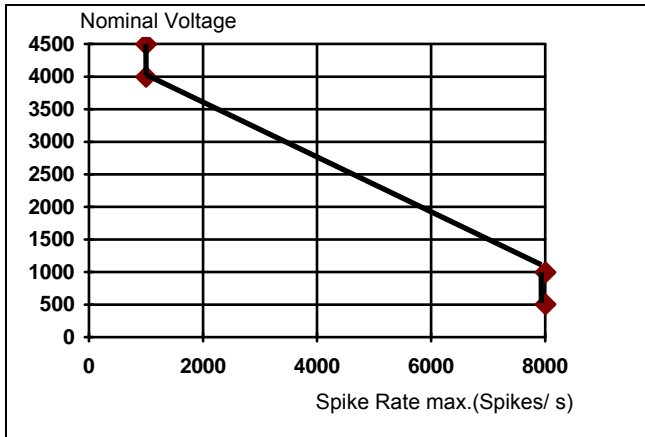

6.2.2.1.2 Spike Rate = number of spikes/ seconds

Selection of coupling path

When pressing "More" the display below will be shown

loaded test

coupling paths



EUT power v, f

coupling paths

The coupling paths can be selected as follows:

1. Set the cursor to the coupling path to editing
2. Select ON or OFF
3. Confirm that the values entered are correct by pressing the ENTER - button.

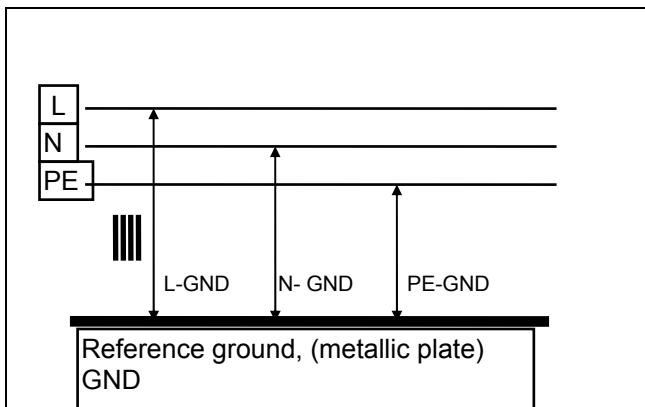

6.2.2.1.3 Definition coupling path

When several coupling paths are activated „ON“, they will be chosen step by step. The sequence corresponds with the sequence listed in the „Main“ menu. When Impulse -Out = On, the burst impulses stay at the high voltage. The capacitive coupling clamp can be connected on the high voltage EFT output (superimposing EFT on data line).

Random Spikes

When pressing "More" the display below will be showed



Randomly distributed spikes can drastically reduce the test time, especially for digital circuits. Weak points of EUT are found very rapidly.

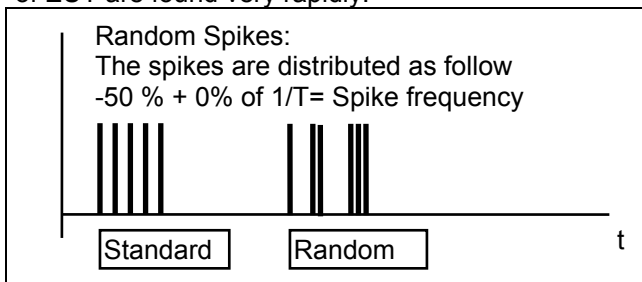

Standard = Random Mode OFF

Random = Random Mode ON

6.2.2.1.4 Definition Random Spikes

6.2.2.2 Synchronisation of a Burst

When the synchronisation „Synchro“ is „power“ selected, the synchronisation will be on the EUT power frequency.

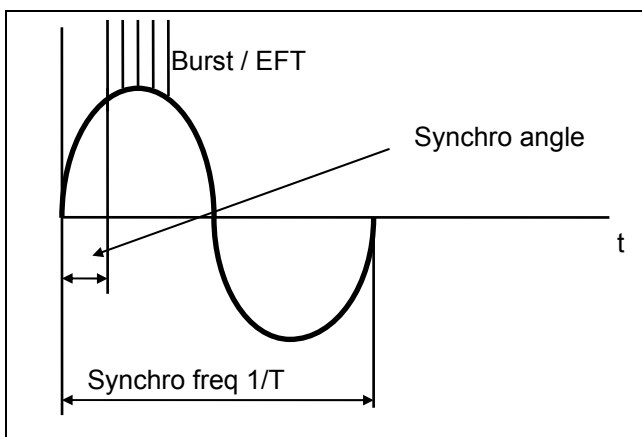

By pressing „Manual“ trigger one burst will be released.

6.2.2.1.5 Definition synchronisation

When the synchronisation „Synchro“ is „power“ the Synchro Deg. will be displayed.



6.2.2.3 Editing ESD test set-up

Editing ESD test set-up

loaded test

test parameters



EUT power v, i

tests parameters

6.2.2.4 When the EDIT button has been pressed the dialogue line indicates the possible range like v, time, etc.

The values can be varied as follows within the given ranges:

1. Set the cursor to the parameter to editing
2. Edit the values as required using the numerical keys
3. Confirm that the values entered are correct by pressing the ENTER - button.

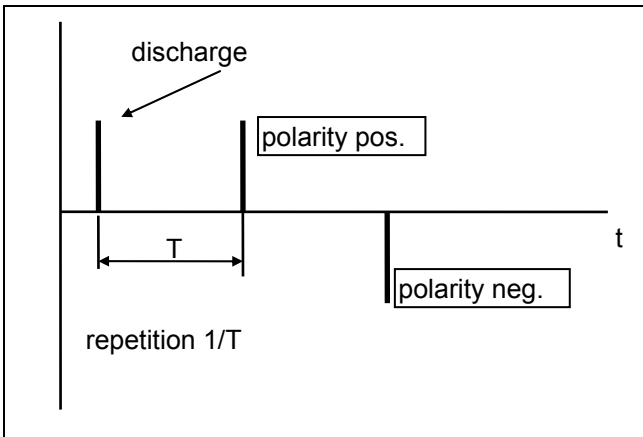

6.2.2.2.1 Definition of ESD parameters

Contact Discharge = Discharge via the „ESD Relay“ tip. The relay tip must be on top of the ESD discharge network. The relay tip must contact the EUT.

Air Discharge = Discharge via the adapter „finger“. The discharge occurs as a spark between the finger and the EUT.

Pulse Counter = On discharge only

Only the impulses whereas the voltage of the discharge capacitor (150 pF) droplower than 10 % of the charging voltage are counted.

Which discharge method must be used? See Chapter 5.4.2.



ATTENTION

When using EXT-TRA3000 E, ensure a ground cable is always connected

6.2.2.5 Editing of SURGE parameters

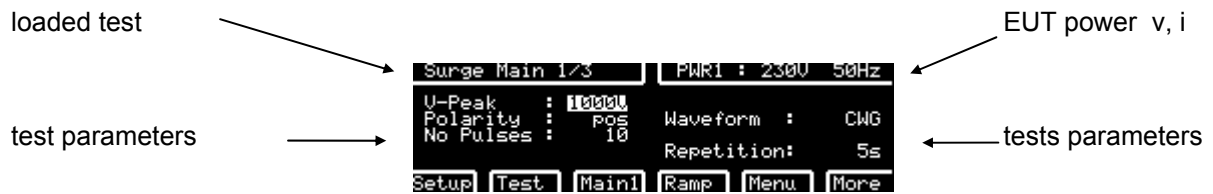

When the EDIT button has been pressed the dialogue line indicates the possible range like v, time, etc.

The values can be varied as follows within the given ranges:

1. Set the cursor to the parameter for editing
2. Edit the values as required using the numerical keys
3. Confirm that the values entered are correct by pressing the ENTER - button.

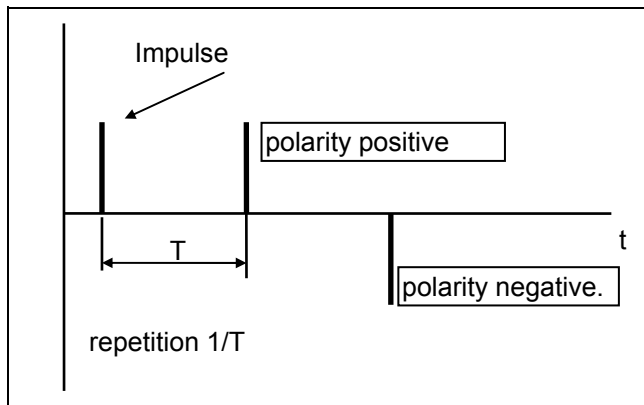

6.2.2.3.1 Definition of SURGE parameters

Repetition:

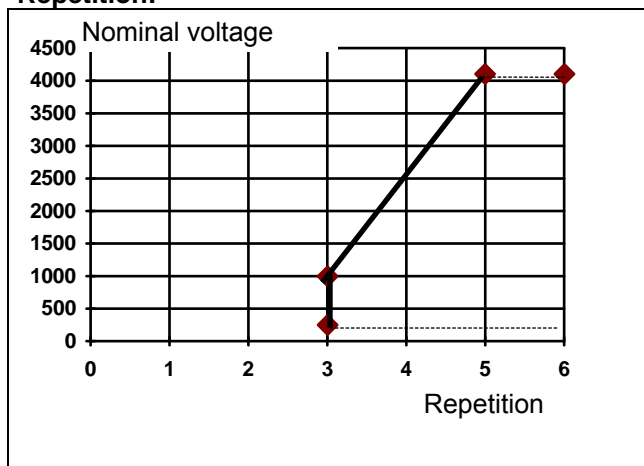

Repetition is defined as the time between two successive impulses. For each discharge the capacitor in the TRA3000 E-F-S-D-V-C must be charged. The stored energy is a function of the charging voltage, therefore the repetition rate is a function of the voltage.

6.2.2.3.2 Minimum time (Repetition) between two successive impulses as a function of the voltage.

6.2.2.6 Synchronisation Power



Different possibilities exist to synchronize the TRA-generator with a three phase coupling filter.

Example: TRA2000/TRA3000

The SURGE impulse must be synchronised with the phase L1 to PE.

Set the black banana plugged cable for Synchronisation and the yellow and red cable for the surge pulse as shown in the pictures .

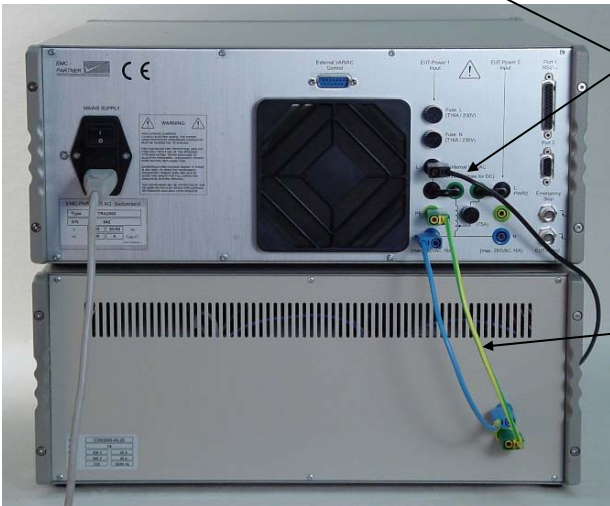

Cable for the synchronisation. Please use the 1 m black cable delivered with the CDN2000 to synchronize the TRA3000 E-F-S-D-V-C with the desired phase of the CDN2000.

In the pictures the synchronisation is made for the Phase L1.

Additionally the neutral and the protective earth must be connected on the rear side of between the TRA3000 E-F-S-D-V-C and the CDN2000

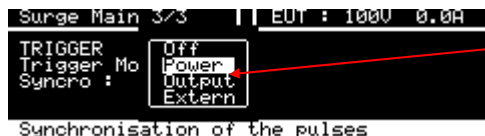

First the synchronisation source must be selected

When the power source is selected

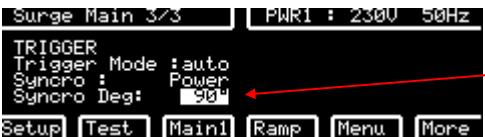

Depending on the SURGE coupling (cable yellow and red) the synchronisation angle must be set as defined below:

Coupling: **Phases to PE or N** and synchronisation (black cable on L1)

- SURGE L1: 0° equal 0°
- SURGE L2: 0° equal 120°
- SURGE L3: 0° equal 240°

Note: The 0° is defined as the angle at which the Surge is superimposed on the power supply depending on the manually selected red yellow connections.

Coupling: **Phases to Phases** and synchronisation (black cable on L1)

- SURGE L1 to L2: 0° equal 330°
- SURGE L2 to L3: 0° equal 90°
- SURGE L1 to L3: 0° equal 30°

6.2.2.7 Synchronisation Output



Note: The θ° is defined as the angle at which the Surge is superimposed on the power supply depending on coupling path selected in the 3P CDN.

Selection of coupling path



When the 2 x V-peak are selected "on" the voltage of the L→N voltage will be doubled as specified in the standard for common and differential tests.

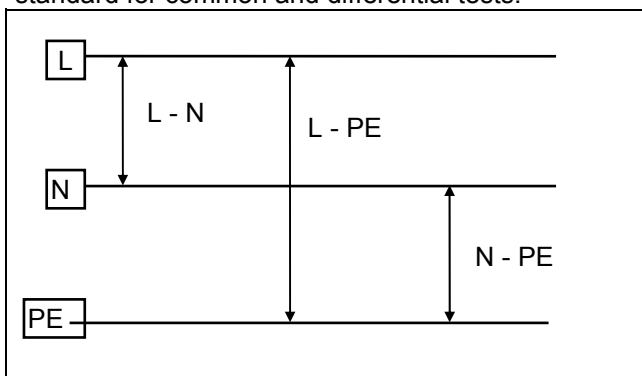

6.2.2.3.3 Coupling path definition SURGE

When several coupling paths are activated „ON“, they will be chosen step by step. The sequence corresponds with the sequence listed in the „Main“ menu. When Impulse -Out = On, the impulses stay at the high voltage (banana plugs). The coupling kit or the three phase filter can be connected on the high voltage SURGE output.

At Power Synchro =ON, the surges are released synchronous to the main frequency.

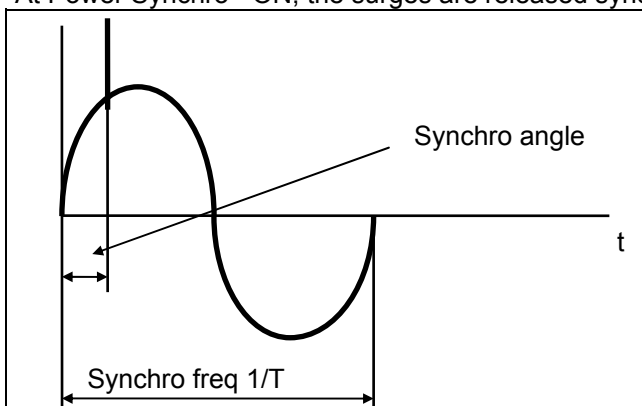

At SURGE Trigger = Manual, the surge is not automatically released after the repetition time, but by operation of the Man-Trigger button.

6.2.2.3.3 Definition synchronisation

6.2.2.8 Editing DIPS less than 1 period

Short Dips are interruptions shorter than one period of the EUT power supply. The duration of a dip is entered as an angle in degrees (°). A maximum of two different dips can be defined per period. Periods with equal dips can be multiplied.

loaded test →

test parameters →

DIP Main 1/4	20° - 40% - 1000hPa
DIP Level : 70%	Mode: <input type="checkbox"/> Period
Test-time : 60s	Duration: 200Per
	Repetition: 3s

← EUT power v, i

← tests parameters

Setup Test Main1 Ramp Menu More

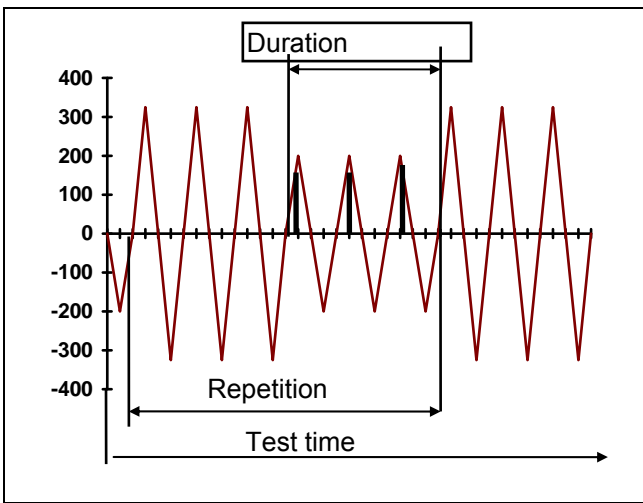

Nbr. of periods is equal the number of disturbed periods. Repetition defines how often the disturbance occurs.

6.2.2.4.1 Definition number of periods, repetition, test time

When the soft key F6 has been pressed:

loaded test →

test parameters →

DIP Main 2/4	+ No next setup
DIP Power Synchronisation :	
First DIP	Second DIP: off
DIP Begin : 80°	
DIP End : 260°	

← EUT power v, i

← tests parameters

Setup Test Main1 Ramp Menu More

When the EDIT button has been pressed the dialogue line indicates the possible range like v, time, etc.

The values can be varied as follows within the given ranges:

1. Set the cursor to the parameter to editing
2. Edit the values as required using the numerical keys
3. Confirm that the values entered are correct by pressing the ENTER - button.

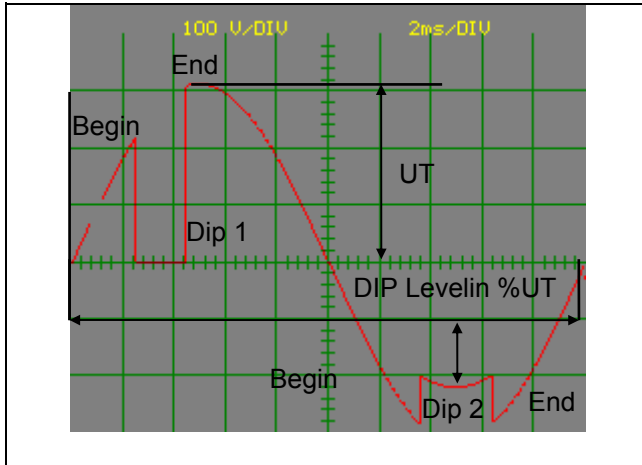

Conditions which must be fulfilled:

DIP End >= DIP Begin
 DIP2 Begin >= DIP 1 Begin

When only one DIP is required, then the DIP 2 can be placed on DIP 1, or DIP2 Begin is equal DIP2 End.

6.2.2.4.2 Definition synchronisation

When the soft key F6 has been pressed:

loaded test

test parameters



EUT power v, i

tests parameters

At an interruption to 0%, two power supply impedance can be differentiated: supply impedance high Z and low Z. At high-Z and 0% = OFF, the EUT will be discharged at DIP begin via a low impedance as happens in reality. Further explanation about high Z, see Chapter 3.4

6.2.2.9 Editing DIPS longer than one period

Long DIPS are interruptions with a duration longer than one period. The duration is specified in ms. The turn ON and OFF angles can be selected.

loaded test →

test parameters →

```

DIP Main 1/4      20°- 40%-1000hPa
DIP Level : 70%  Mode: >1 Period
Test-time : 60s   Duration: 200ms
                  Repetition: 3s
    Setup Test Main1 Ramp Menu More
    
```

EUT power v, i ←

tests parameters ←

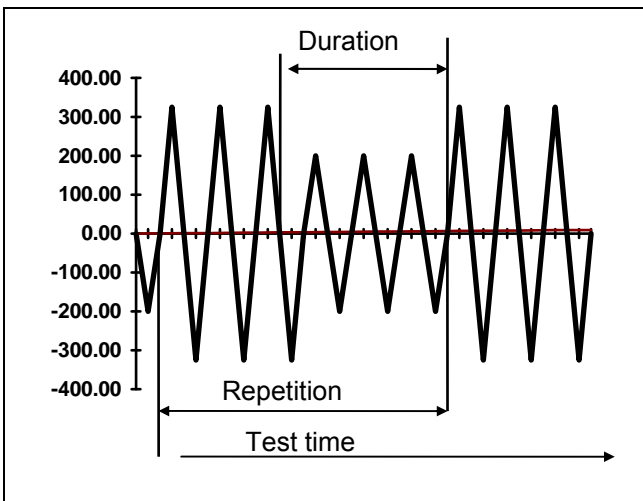

Duration is the length of time of the lowered voltage. Repetition defines how often the disturbance occurs.

6.2.2.5.1 Definition duration, repetition, test time

When the soft key F6 has been pressed:

loaded test →

test parameters →

```

DIP Main 2/4      20°- 40%-1000hPa
DIP Power Synchronisation :
DIP Begin : 80°
DIP End : 260°
    Setup Test Main1 Ramp Menu More
    
```

EUT power v, i ←

tests parameters ←

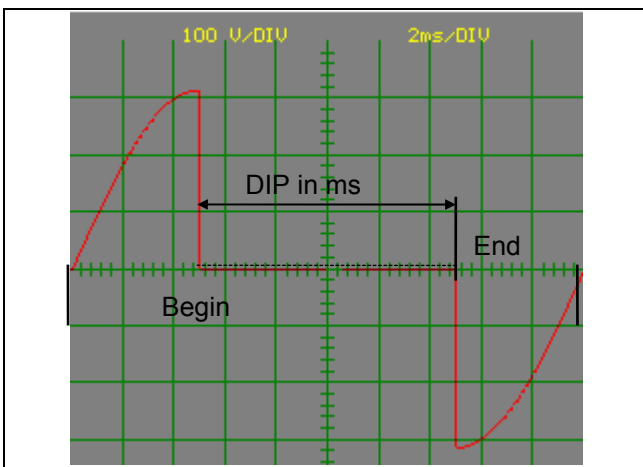

6.2.2.5.2 DIP Begin, DIP End

The TRA3000 E-F-S-D-V-C processor calculates the number of disturbed periods as a function of the chosen duration. The condition for a correct test is the correctly selected power frequency, in the range of

($16^{2/3}$ to 400 Hz). If the angle of DIP Begin and DIP End are different, the DIP duration will be adapted e.g. for End > Begin longer or for Begin > End shorter.

Interruption to 0% with and without EUT discharge

6.2.2.10 When the soft key F6 has been pressed:

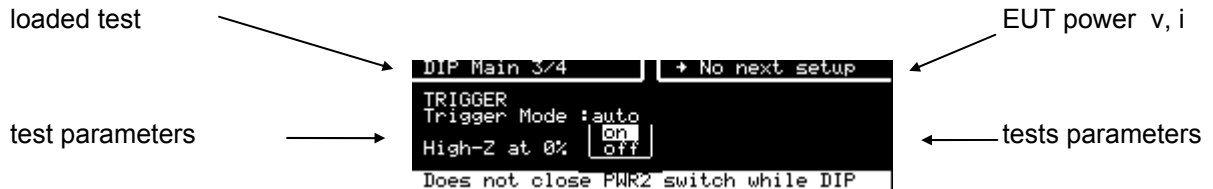

At an interruption to 0 %, two modes can be differentiated:

A) High Z at 0% = ON

In this mode, the voltage across the EUT decreases with the time constant of the EUT during an interruption.

B) High Z at 0% = OFF

Some μ s after the DIP begin, the EUT input will be discharged via the EUT Power 2 circuit.

For more information see Chapter 3.4

6.2.2.11 Editing the test set-up "Variation" Ed.2



Set the parameter by activation with the white cursor in the display

6.2.2.12 Editing the test set-up "Variation" Ed.1



6.2.3 Editing „Ramp“

A „Ramp“ is defined as a linear change of either voltage, angle, frequency, etc. as a function of time.

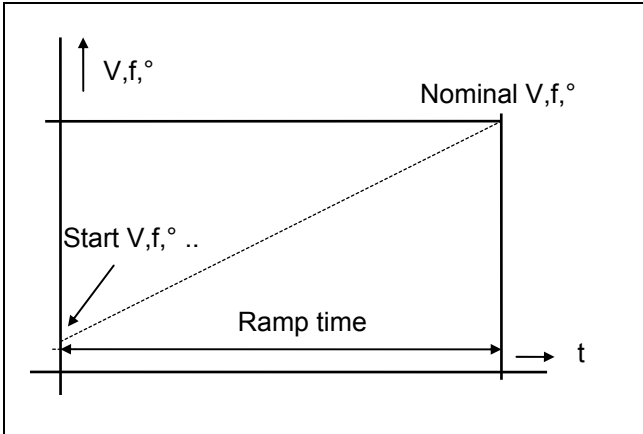

Remarks:

If several coupling paths are selected at SURGE or EFT, the ramp will be performed for each coupling path.

e.g.
L-GND; N-GND; PE-GND

6.2.3.1 Definition of a ramp

The steps of a „Ramp“ depend on the ramp time and the difference between the nominal and start- values.

6.2.3.1 EFT Ramps

loaded test →

possible ramps at EFT →

EFT Ramp 2-2010 19:38

Ramp Kind

- No Ramp
- V-Peak
- Spike Freq
- Burst Dur.
- Synchro Dec

Select a ramp type with f/↓

← EUT power v, i

When V-peak is selected:

loaded test →

V-peak ramp →

EFT Ramp PWR2 : 0U 50Hz

Ramp Kind : V-Peak

+ from 1000U up to 4400U in 20s

Setup Test Main Ramp Menu More

← EUT power v, i

Ramp: Spike amplitude (voltage)

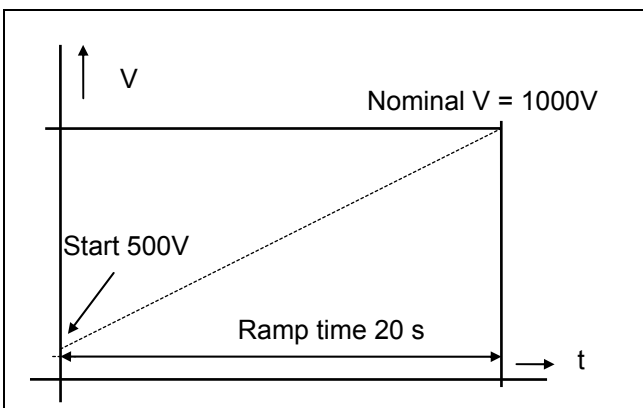

6.2.3.1 Example ramp definition

In the example in picture 6.2.3.1, the voltage will be increased from 500V to 1000 V in 20 seconds. The steps or resolution of the ramp depend on the ramp time and on the voltage difference between V Nominal and V-peak start.

Ramp: Spike frequency

The steps or resolution of the ramp depend on the ramp time and frequency difference between f nominal and start frequency. The chosen number of spikes (=10) per Burst is constant. As a consequence the burst duration decreases with increasing spike frequency. The energy content of one burst is constant. The constant energy per burst simplifies the failure analysis. When a failure occurs at higher frequency the failure relates to the frequency and not to the energy The burst duration is no longer applicable.

Ramp: Burst duration ramp

When analogue circuits are tested, the energy per burst is very important. With the burst duration ramp, the number of spikes will be continuously increased and therefore also the energy. If RC networks e.g. filters, are integrated into a circuit, the disturbance energy can be defined with this mode.

Ramp: Synchronisation angle

With this setting the synchronisation angle of synchro start is continuously adjusted from start angle to stop angle.

6.2.3.2 ESD Ramp

loaded test

EUT power v, i

possible ramps at ESD

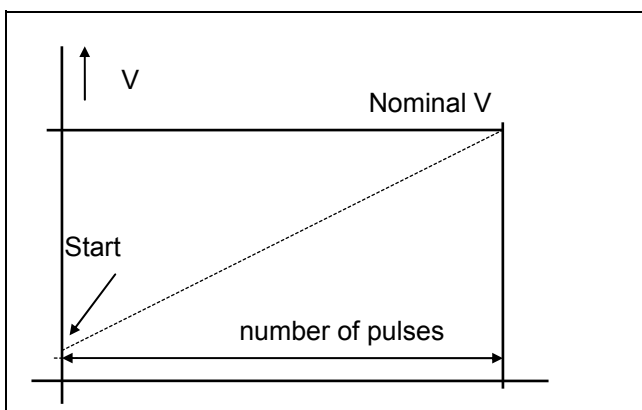

6.2.3.2.1 Definition ramp

Example Voltage

The voltage will be increased from 2000 V to 8000 V with a 500 V step voltage after every 10 discharges.

loaded test

possible ramps at EFT

EUT power v, i

```

ESD Ramp      20"-40%-1000hPa
Ramp Kind : U-charge
+ from 4000U to 16000U
step 500U after every 5 pulses
Setup Test Main1 Ramp Menu More
    
```

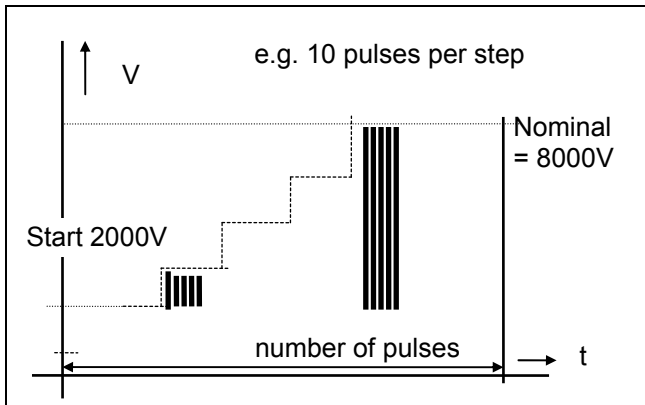

6.2.3.2.2 Definition ramp ESD

6.2.3.3 SURGE Ramp

loaded test

EUT power v, i

possible ramps at SURGE

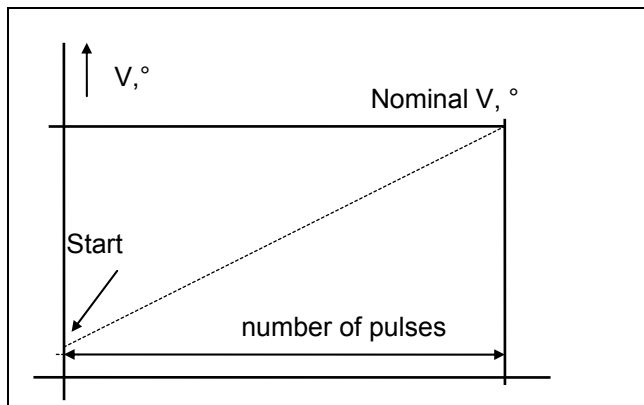

6.2.3.3.1 Definition SURGE ramp

Example Voltage

loaded test

EUT power v, i

V-Peak ramps at SURGE

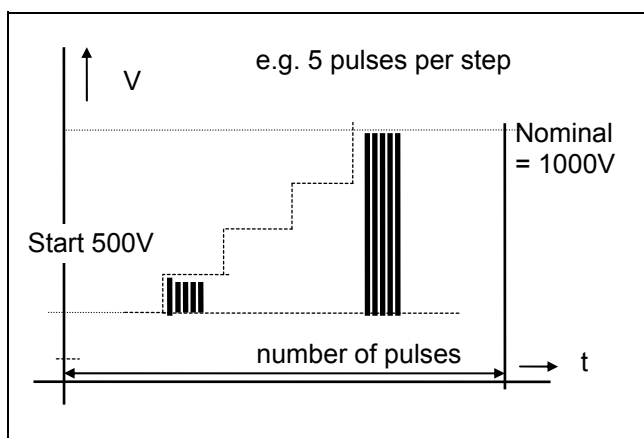

The nominal voltage can also be selected in „Main“ menu.

6.2.3.3.2 Definition SURGE ramp

6.2.3.4 DIPS

loaded test →

possible ramps at DIP →

EUT power v, i ←

```

DIP Ramp | No Ramp | 8 disconnected
Ramp Kind | Level
          | Duration
          | DIP Begin
          | DIP End
          |-----|
          | Select a ramp type with ↑/↓
    
```

Example Level Ramp: Amplitude as % of EUT voltage

loaded test →

Level ramp at DIP →

EUT power v, i ←

```

DIP Ramp | USB disconnected
Ramp Kind : Level
+ from 70% to 110%
  step 10% after every 5 DIPS
          |-----|
          | Setup | Test | Main1 | Ramp | Menu | More
    
```

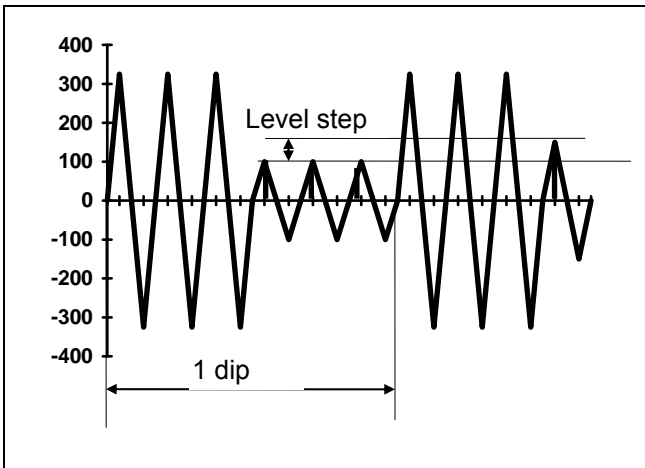

6.2.3.4.1 Definition DIP level ramp

The start of the ramp begins at 100% and changes with „Level step“ (10%) to the DIP voltage. If the test time has been selected to be long enough, the voltage UT will be reached.

Ramp: Length of interruption in ms:

loaded test →

Duration ramp at DIP →

EUT power v, i ←

```

DIP Ramp | PWR2 : 0V 50Hz
Ramp Kind : Duration
+ from 200ms to 29999ms
  step 1ms after every 5 DIPS
          |-----|
          | Setup | Test | Main1 | Ramp | Menu | More
    
```

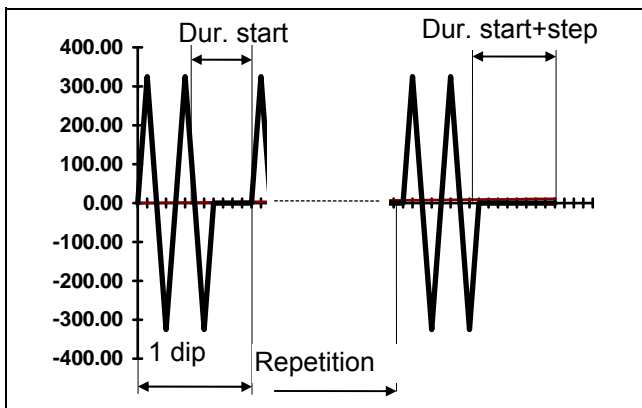

Smallest step is $1/f$. (f =Mains Power frequency EUT)
 The Begin and End angles remain constant as selected in „Main menu“.

6.2.3.5.2 Definition duration ramp

The chosen DIP Begin and DIP End angles remain constant during a duration ramp. As a consequence, the duration does not change continuously, but over one period.

Ramp: Ramp angle at DIP Begin:

loaded test

Duration ramp at DIP

EUT power v, i



At DIP Begin, the angle changes within the range specified.

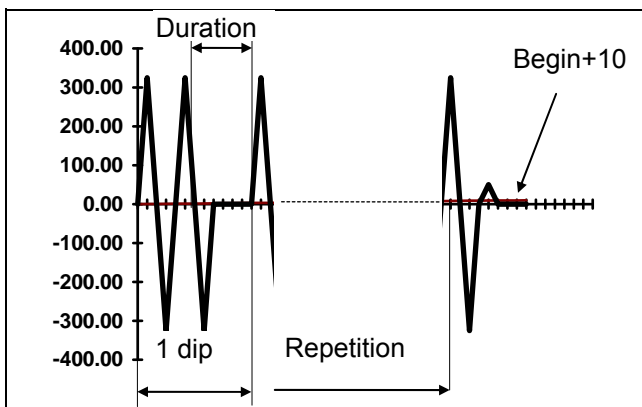

6.2.3.5.3 Definition ramp

Ramp: Ramp angle at DIP End:

At End Ramp, the angle will be changed in steps of 5° from 90° to 0° when the EUT power is turned on. With this mode the inrush current after a interruption can be investigated.

6.2.3.5 Variation Ramp

loaded test →

ramps at Variation →

```

Variation Main      PWR2 : 00 50Hz
tn= 5s  ↓ td mode: Abrupt  |ti| = 25Per
Nominal: 230V  ts=250Per /Level: 70%  Cycles: 1
SiCSetup  Test  Main1  Menu
    
```

EUT power v, i ←

loaded test →

ramps at Variation →

```

Variation Main      → No next setup
tn= 5s  ↓ td mode: Abrupt  |ti| = 25Per
Nominal: 230V  ts=250Per /Level: 70%  Cycles: 1
Setup  Test  Main1  Menu
    
```

EUT power v, i ←

6.2.3.6 EUT Error control

EUT error information can come from three different sources:

1. From EUT failed input on the rear side of the TRA3000 E-F-S-D-V-C,
2. From the SURGE limiter and
3. From the current limiter

The error can initiate different actions:

	Acoustic signal	Remark in the report	Message on display	Abort the test
Protocol	x	x		
Next Setup	x	x	x	
Stop Run	x	x	x	x

EUT →

→

```

EUT-Control      || 20"- 40%-1000hPa
Action if FAILED Protocol
                  Next Setup
                  Stop RUN
Action when EUT is FAILED
    
```

EUT power v, i +++ ←

2. From the SURGE limiter

loaded test →

ramps at Variation →

```

EUT-Control      28-02-2010 20:01
Action if FAILED: Protocol
Upeak-max : 9999V Ipeak-max : 9999A
Upeak-min : 0V Ipeak-min : 0A
Setup  Test  Main1  Ramp  Menu  Main1
    
```

EUT power v, i ←

Limits for SURGE peak measurements:

If selected limits are exceeded a message appears on the display. An error will be registered within a limited time. (See diagram on next page).

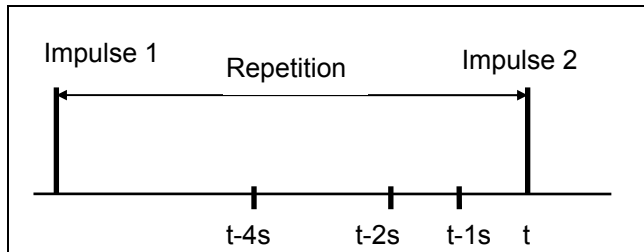

6.2.4.3 Time window for error message SURGE

At $t-4$ seconds, the charging of the SURGE capacitor for the next impulse number 2 starts.

$t-2$ seconds is the last possible opportunity to give an error message from impulse number 1 via the EUT failed input on the rear side of the TRA3000 E-F-S-D-V-C.

At $t-1$ second, the data of impulse 1 will be printed out and the error message will possibly be reset.

6.3 EMC test operation „RUN Mode“

Before you start an EMC test, you should be familiar with the following:

„Run Mode“ is defined as an EMC test operation such as EFT, ESD etc. The „Run Mode“ is indicated by the blinking LED on the operation panel of the front. Pressing the RUN-button sets the TRA3000 E-F-S-D-V-C into the RUN mode. During RUN Mode, the corresponding test-LED on the operation part blinks and the corresponding coupling path is illuminated.

Renewed pressing of the RUN-button stops the generator (Reset to the standby mode).

In „Standby Mode“ the power to the TRANSIENT is switched on. The control is activated. No high voltage source is switched on.

Depending on local safety standards, an emergency stop must be installed. All operators and laboratory personnel must be able to reach the emergency stop. On the rear side of the TRA3000 E-F-S-D-V-C there is an **EMERGENCY STOP** input. See Chapter 5 „Preparation for Operation“.

Trigger.

After the RUN button has been pressed, the tester is started, but not the EMC test. As soon the generator is ready (e. g., the impulse capacitor is charged), the LED on the trigger button is illuminated. As soon as the LED is illuminated a single EMC test can be initiated (Burst, ESD, DIP, Variation). The next trigger can take place when the LED is illuminated again.

During ESD, the trigger button has the same function as the button on the ESD discharge network.

6.3.1.1 Changing values during operation

In RUN-mode, most of the parameters can be continuously varied using the „+“ and „-“ buttons. This is very helpful for exactly determining of the immunity level of the EUT. The manual change of the nominal voltage will be noted in the report with a warning.

If ramp has been chosen, the different values will change as follows:

Voltage ramp	V-peak	V
Frequency ramp	Freq.	kHz
Burst duration	Burst	Dur
Synchronisation	Synchro	°

For very fast investigation the coupling paths can also be changed during operation by pressing the N, PE, L buttons.

6.3.1.2 EFT operation

test in operation

test voltage and time bar. Black indicates the actual test time carried out

indicates the status of the actual test.

when the operator visually detects a EUT failure, F4 can be pressed and the status of the test turns to "failed". Protocol shows " test failed"

by pressing "Mark" the actual test parameter will be written in the protocol and showed on the display at test end.

EUT power v, i

In operation mode the values can be changed without changing the programmed test

The values can be varied as follows within the given ranges:

1. Set the cursor to the parameter to changing
2. With the + or - buttons the values can be changed during operation
3. The protocol will be extended with a remark

6.3.1.3 ESD operation

In the RUN-mode the nominal voltage (V-peak) can be continuously varied using the „+“ and „-“ buttons. This is very helpful for exactly determining the immunity level of the EUT. The manual change of the nominal voltage will be noted in the report with a warning see example EFT. The ESD discharge network must be connected to the outputs HV and Control.

6.3.1.3.1 Contact Discharge

Press "RUN" and contact EUT with the relay tip.

test in operation

test voltage and what to do

indicates the status of the actual test

when the operator visually detects an EUT failure, F4 can be pressed and the status of the test turns to "failed". Protocol shows " test failed"

by pressing "Mark" the actual test parameter will be written in the protocol and showed on the display at test end.

EUT power v, i

discharge mode

5 pulses of 20 are made

The values can be varied as follows within the given ranges:

1. Set the cursor to the parameter to changing
 2. Change with the + or - buttons the values during operation
- To stop the running test, press the red RUN button.**

6.3.1.3.2 Air Discharge

The „ESD Finger“ Adapter must be on top of the ESD discharge network. After pressing the RUN-button:

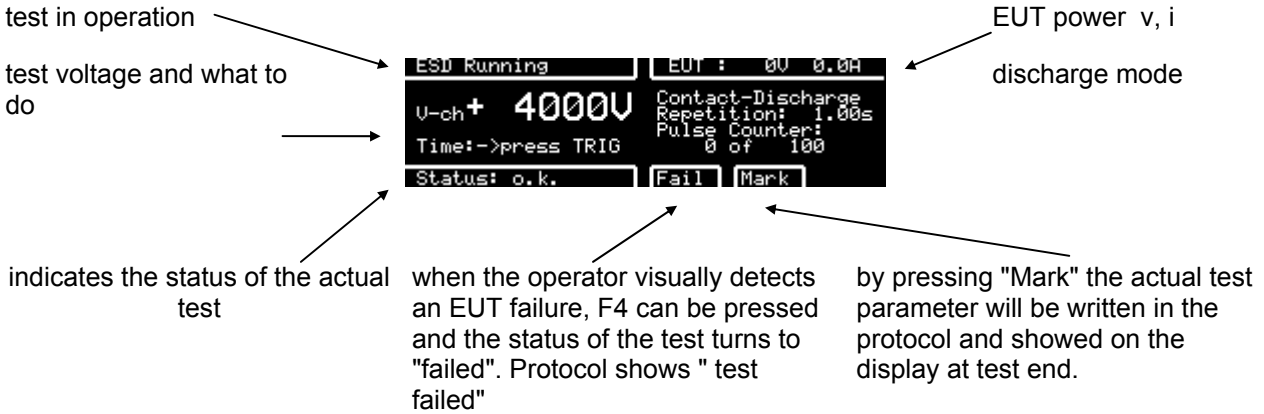

Air discharge Sequence

1. Press the button on the ESD discharge network as soon as the request „press button“ appears on the display. The capacitor in the ESD discharge network will be charged to the preselected voltage.
2. As soon as a „Beep“ sounds, the finger can be moved against the EUT. The display shows „contact EUT“. For the movement against the EUT a maximum of 5 Seconds are reserved, corresponding to the holding time in the standard.
3. When the discharge onto the EUT has occurred, you need not to wait 5 seconds. By pressing the button a second time, either two or three „Beeps“ will be heard. Two beeps means no full discharge has occurred, and the discharge will not be reported. Three beeps means the discharge occurred, and the discharge will be counted and reported..

For the next discharge, steps 1 to 3 must be repeated.

6.3.1.4 SURGE

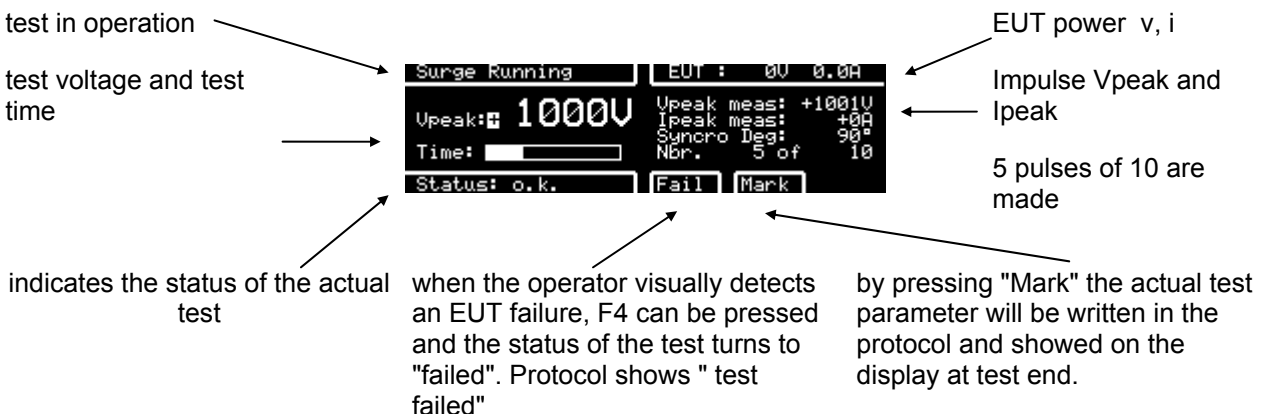

6.3.1.5 DIPS less than 1 period

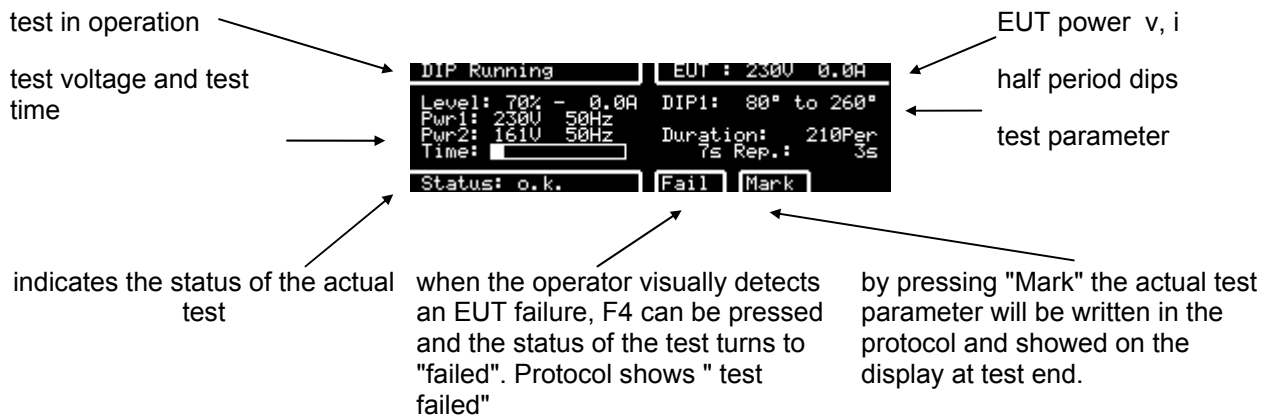

For the interruption and Variation test the EUT Power 1 input on the rear side of the TRA3000 E-F-S-D-V-C must be connected to the public power mains. Connecting the TRANSIENT to the public power mains is explained in Chapter 5.

To stop the running test, press the RUN button.

6.3.1.6 DIPS more than 1 periode

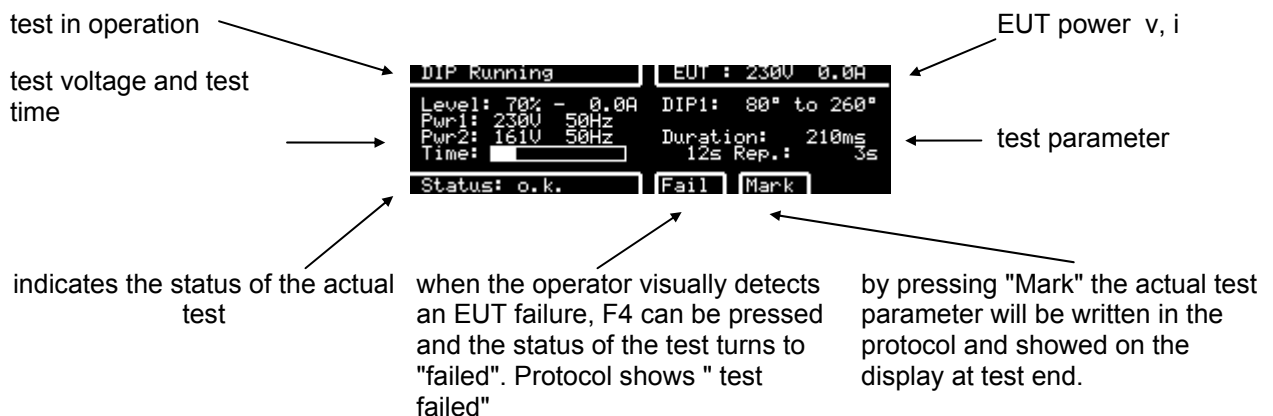

For the interruption and Variation test the EUT Power 1 input on the rear side of the TRA3000 E-F-S-D-V-C must be connected to the public power mains. Connecting the TRANSIENT to the public power mains is explained in Chapter 5.

To stop the running test, press the RUN button.

6.3.1.7 Variation

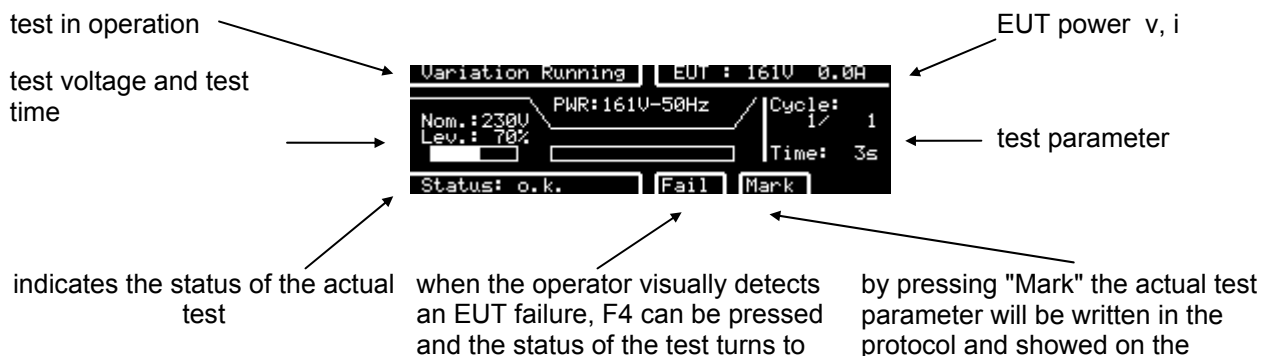

"failed". Protocol shows " test failed" display at test end.

For the interruption and Variation test the EUT Power 1 input on the rear side of the TRA3000 E-F-S-D-V-C must be connected to the public power mains. Connecting the TRANSIENT to the public power mains is explained in Chapter 5.

6.3.1.8 Magnetic Field

test in operation

test voltage and test time

indicates the status of the actual test

when the operator visually detects an EUT failure, F4 can be pressed and the status of the test turns to "failed". Protocol shows " test failed"

by pressing "Mark" the actual test parameter will be written in the protocol and showed on the display at test end.

EUT power v, i

type of induction coil to use and current range of the induction coil

6.3.1.9 Interruption on d.c.

test in operation

Voltage will be indicated when on PWR1 on the rear of TRA3000 a d.c. voltage is connected

EUT power v, i, +++

test in operation

Voltage will be indicated when on PWR1 on the rear of TRA3000 a d.c. voltage is connected

EUT power v, i, +++

Indicates the test parameter

test in operation

Voltage will be indicated when on PWR1 on the rear of TRA3000 a d.c. voltage is connected

EUT power v, i, +++

Indicates the test parameter

6.4 Operating System Displays

6.4.1 Rolling information lines

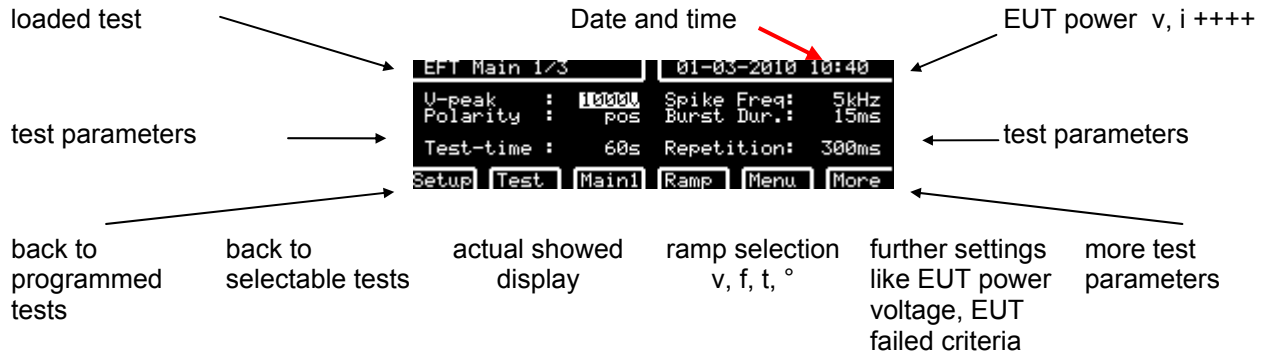

When the GENECs Demo Program is used the date and time is taken from the Microsoft Windows. The date and time of the TRA3000 can be set in the following Windows



The rolling information line changes as follow:

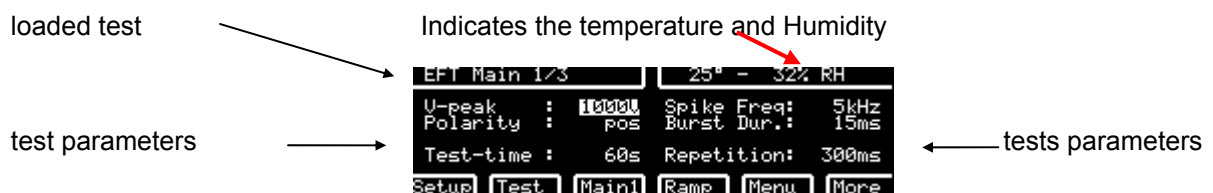
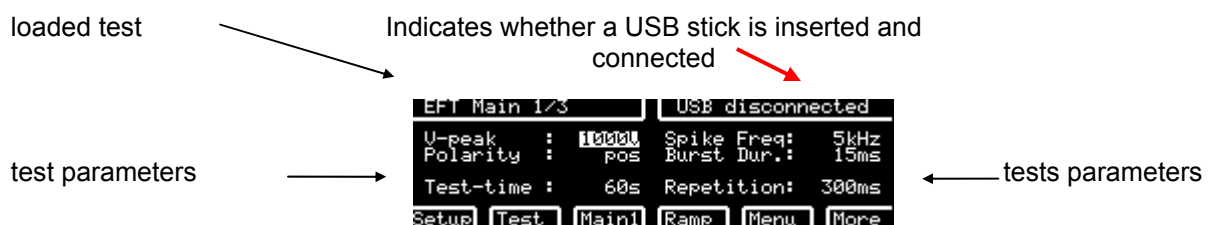

The sensor inside the TRA3000 does only intricate approximately the temperature. For precise measurement external sensors must be used. External sensor must be ordered separately.

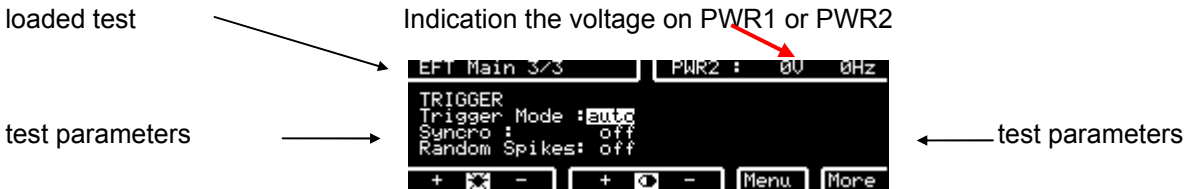
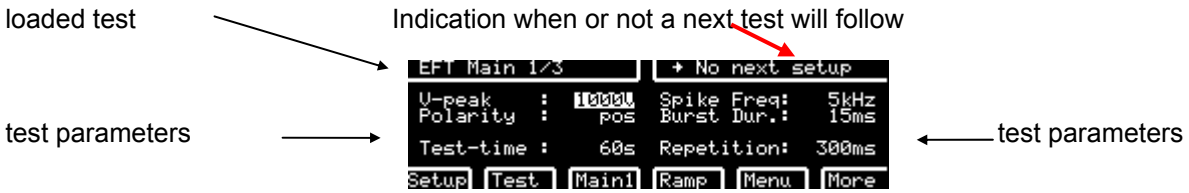

In this Display the backlight and the brightness of the display can be regulated

6.4.2 Service access and firmware upload

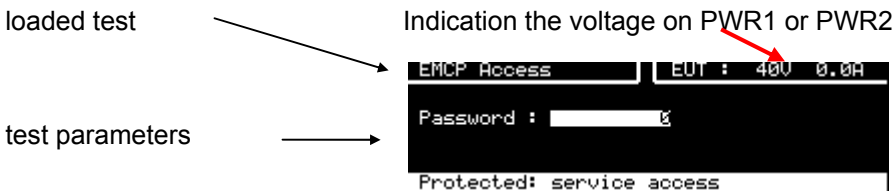

Service access is only possible with a password.

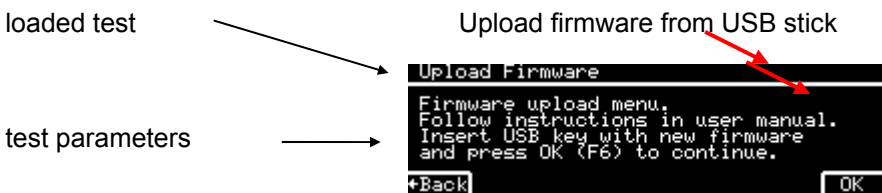

6.4.3 Web Server

Version: 1.00
S/N: 1215
Calibrated: 22-09-2009

TRA3000

EMC -
PARTNER 

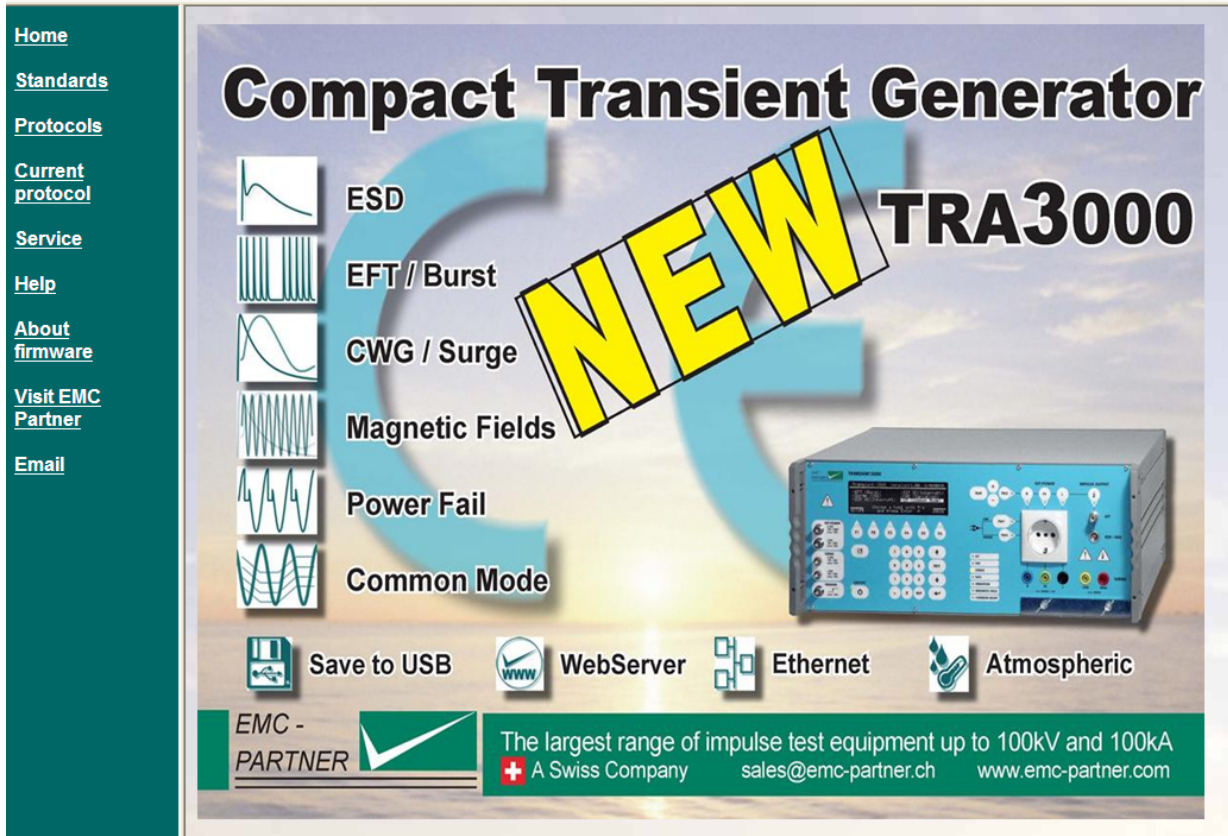

Standards:

Gives an overview about all possible basic test with the TRA3000

Protocols

Shows a list of up to 200 protocols made with the TRA3000

Current protocol

Shows the protocol of the last test

Service

Diagnostic files and info . The diagnostic file has always to be sent to EMC PARTNER in case of service or repair problems.

Help

Help information to the web server

About firmware

Indicates the serial number of the TRA3000, software version, etc.

Visit EMC Partner

When the PC is connected to the internet, the EMCP web Site will be displayed.

Email

Send an Email to EMCP service department

7 Maintenance and Servicing

7.1 Maintenance

To avoid electrical shock, be sure that the power cord is disconnected before starting maintenance work. EMC PARTNER recommends that the air filter of the ventilator be cleaned from time to time. The cleaning cycle depends on the environmental conditions. Place the air filter of the ventilator in soapy water for 15 minutes. After 15 minutes, the air filter must be dried before being reinstalled.

If the DIPS and Variation circuit is used very often with high current, the VARIAC brushes must be changed.

No further maintenance is necessary on the TRA3000 E-F-S-D-V-C.

7.2 Verification versus Calibration

7.2.1 Verification Example IEC 61000-4-4 Ed.2

Set of operations which is used to check the test equipment system (e.g. the test generator and the interconnecting cables) and to demonstrate that the test system is functioning within the specification given in Clause 6

☛ Note 1 the method used for verification may be different from those used for calibration

☛ Note2 The procedure of 6.1.2 and 6.2.2 is meant as a guide to insure the correct operation of the test generator, and other items making up the test set-up so that the indeed waveform is delivered to the EUT Customer has to do it before a serie of tests starts

7.2.2 Calibration Example IEC 61000-4-4 Ed.2

Set of operation which establishes, by references to standards, the relationship which exists under specific conditions, between an indication and a result of a measurement.

☛ note 1 This terms is based on the “uncertainty” approach

☛ Note2 The relationship between the indications and the results of measurements can be expressed, in principle, by a calibration diagram.

7.3 Verification of the TRA3000 E-F-S-D-V-C by the user

A verification whether high voltage pulses occur at the tester outputs can be carried out using an oscilloscope of a bandwidth of 20 MHz.

7.3.1 EFT

1. Setting EFT Test „Main Menu“

V = 500 V; f = 100 kHz; Burst duration 10ms; Coupling path N-PE

2. Measuring points:

With 10x probe at banana plug output marked N, connect ground to the earth terminal rail

3. Settings at the oscilloscope

Time base 10 to 50 ms,

Vertical deflection 5 V / division

On the CRO screen, the Burst must be visible. The single spike is not visible because the bandwidth is insufficient.

7.3.2 ESD

1. Select 8 kV charging voltage and repetitions frequency 1Hz
2. Discharge to a ground plate. A spark of approximately 3 mm length must be visible.

7.3.3 SURGE

Verification as specified in the Basic Standard 1000-4-5.

- Measurement of output voltage at no load
- Measurement of short circuit current with short circuit output
- Check that voltage and current waveforms are within the tolerances.
- Calculate the source impedance from the peak voltage divided by the peak current.

1. Setting SURGE Test „Main Menu“

V = 1000 V; repetition 5s; coupling path L-N,

Attention!! The power cord must be removed from the inputs EUT Power 1 and 2 of the rear side.

2. Measuring points:

SURGE U-CRO for the voltage measurement at no load

SURGE I-CRO for current measurement at short circuit (make a short circuit on the front panel of the TRA3000 E-F-S-D-V-C using a banana plug type cable 1000 between L-N)

3. Setting measuring equipment

Time base 5 μ s,

Vertical deflection 0.5 V / division

Definition of the wave-forms and their tolerances, see Chapter 14.1

7.3.4 Interruption

Verification as specified in the Basic Standard 61000-4-11.

Trigger the measuring equipment via the external trigger input. Different trigger level, see Chapter 1.2.7

7.3.5 Variation

1. Setting TRA3000 E-F-S-D-V-C Setup Var 2s1s2s

2. Measuring point:

BNC output EUT Power U.

3. Setting measuring equipment

Time base 10 to 50 ms,

Vertical deflection 2 V / division

The voltage variation can be measured with the oscilloscope.

7.4 Calibration of the TRA3000 E-F-S-D-V-C by EMC PARTNER AG

EMC PARTNER calibrate every EXT-TRA3000 E-F-S-D-V-C in accordance with the calibration chapter within the Basic Standards. Before a TRA3000 E-F-S-D-V-C is delivered, calibrations are carried out in accordance with the basic documents.

All data are within the tolerable tolerances.

See calibration report EXT-TRA3000 E-F-S-D-V-C delivered with the generator or EXT-TRA3000.

Demand a quote for calibration

EMC PARTNER recommend a calibration of the EXT-TRA3000 E-F-S-D-V-C every **two years**. All calibration reports include detailed measurement data including oscillogramms.

A calibration without a repair takes approximately 3 days.

7.5 Service of SPD Surge Protective device

	<p>VAR BOX Art Nr 104387</p>
<p>Box with varistors 300V S20K300 to TRA3000</p>	

The VAR BOX protects the TRA3000, when too high power supply voltage is applied to the EUT power input or the TRA3000 power output to the EUT or when the EUT generates a too high surge voltage.

Customers can change the varistor box by removing the TRA3000 top cover.

8 What must be done following failed operation

The TRA3000 generators have many different messages to assist the operator solving possible problems, give information regarding incorrect operation of the TRANSIENT-generator, or to correct an incorrect system configuration. Basically, three different messages can be differentiated:

- Error message based on incorrect inputs
- Error based on incorrect operation of the generator
- Warning messages

8.1.1 Error caused by incorrect inputs „Generator not ready for run“

Message	Description
Emergency stop active	An emergency stop has been operated via the BNC outlet „Emergency Stop“ on the rear of the TRA3000 E-F-S-D-V-C.
Variac input voltage fault	The variac could not be set to the correct value. Please check: -Is voltage on EUT Power 1? -variatic bridges inserted on the rear panel? -variatic fuse o.k.?
Variac input frequency fault	The variac is only designed for 50/60Hz. Please check: -Is frequency on EUT Power 1 out of range? -variatic bridges removed on the rear panel? -variatic fuse o.k.?
No Variac input	The variac has no power. Please check: -Is voltage on EUT Power 1? -variatic bridges inserted on the rear panel? -variatic fuse o.k.?
No coupling path defined	In the „Main“ menu no coupling path for superimposing SURGE and EFT onto the power line has been defined.
Repetition < 100ms	At EFT: When synch mode = On, the Burst repetition must be greater than 100 ms.
No power input	Check power voltage on EUT input on rear of TRA3000 and the 16A fuse.
Hardware power status fault	Press any of the front panel buttons. Repeat the test If there is no change contact EMC PARTNER
Power must be 0V	Select in the Power menu „Main“ instead of „0“.
Input power N> 50V and L-N <N	Interchange L and N

8.1.2 Error caused by running problem „Generator stopped“

EUT FAILED: Vpk: xxxxV > xxxxV	The selected voltage limits have been exceeded during SURGE testing. -Check limits -EUT is defective.
EUT FAILED: Vpk: xxxkV <xxxkV	During SURGE test, the voltage has fallen below the selected voltage limits: -Check limits -EUT is defective.
EUT FAILED: Ipk: xxxkA > xxxkA	The selected current limits have been exceeded during SURGE test. -Check limits -EUT is defective.
EUT FAILED: Ipk: xxxkA <xxxkA	During SURGE test, the current has fallen below the selected limits: -Check limits -EUT is defective.
EUT FAILED: External event	The input EUT failed has been activated (grounded). -Check EUT failed -EUT is defective
EUT FAILED: by operator	The operator has pressed FAIL on the front panel. .
Overcurrent: I-power : xxxA (>xxA)	FOR generators with built in CDNs. The continuous current of the EUT limit has been exceeded (AC)
Manual Trigger Timeout (>100sec)	During SURGE and with manual trigger, the high voltage will be switched off after 100 seconds, if no pulses have been released..
HV discharge timeout (>10s)	FOR generators with EXT-TRA3000 E (ESD) the high voltage will be switched off after 10 seconds, if no pulses have been released in air discharge mode.

8.1.3 Failure based on error at the generator „Hardware error“

Generator malfunctioning	Title of the message followed by the information below
No high-voltage	The voltage of the high voltage source of the TRA3000 E-F-S-D-V-C cannot be increased. Press any of the front panel buttons. Repeat the test. If there is no change contact EMC PARTNER.
High-voltage overshoot	The high voltage has exceeded a voltage limit. Press any of the front panel buttons. Repeat the test. If there is no change contact EMC PARTNER.
Self firing	The pulse release has been before the trigger released. Press any of the front panel buttons. Repeat the test. If there is no change contact EMC PARTNER
No firing	The pulse release has not functioned. Press any of the front panel buttons. Repeat the test. If there is no change contact EMC PARTNER
Variac fault	The variac could not be set to the correct value. Please check: -Is voltage on EUT Power 1? -variac bridges inserted on the rear panel? -variac fuse o.k.?
High voltage regulation fault	The high voltage regulation of the source is not functioning correctly. Press any of the front panel buttons. Repeat the test If there is no change contact EMC PARTNER
No synchronisation signal	Check power voltage on EUT input on rear of TRA3000 and the 16A fuse. When a external CDN is used, check the voltage on the direct output of the TRA3000.
ESD fault	Press any of the front panel buttons. Repeat the test If there is no change contact EMC PARTNER
EFT fault	Press any of the front panel buttons. Repeat the test If there is no change contact EMC PARTNER
DIPS fault	Press any of the front panel buttons. Repeat the test If there is no change contact EMC PARTNER
Basis fault	Press any of the front panel buttons. Repeat the test If there is no change contact EMC PARTNER
SURGE fault	Press any of the front panel buttons. Repeat the test If there is no change contact EMC PARTNER
HV charge timeout	Press any of the front panel buttons. Repeat the test If there is no change contact EMC PARTNER
Capacitor voltage to low	Press any of the front panel buttons. Repeat the test If there is no change contact EMC PARTNER
Communication error	Press any of the front panel buttons. Repeat the test If there is no change contact EMC PARTNER
Bad parameter for this extension	Check parameter setting for the selected test set up.
Error on PWR1	Check power voltage on EUT input on rear of TRA3000 and the 16A fuse.
Error on PWR2	Check power voltage on EUT input on rear of TRA3000 and the 5A fuse.

8.2 Service; Repairs

The TRA3000 E-F-S-D-V-C is a compact equipment for service the different EXT-TRA3000 modules can be interchanged by the customer or by EMC PARTNER authorised service companies.

List of EXT-TRA3000:

- EXT-TRA3000 E (ESD)
- EXT-TRA3000 F (Electrical Fast Transient, Burst)
- EXT-TRA3000 S (Surge)
- EXT-TRA3000 D (DIPS)
- EXT-TRA3000 V (Vaiaac, Variation)
- EXT-TRA3000 C (Common Mode Disturbance)

8.2.1 Service Flowchart of TRA3000 System:

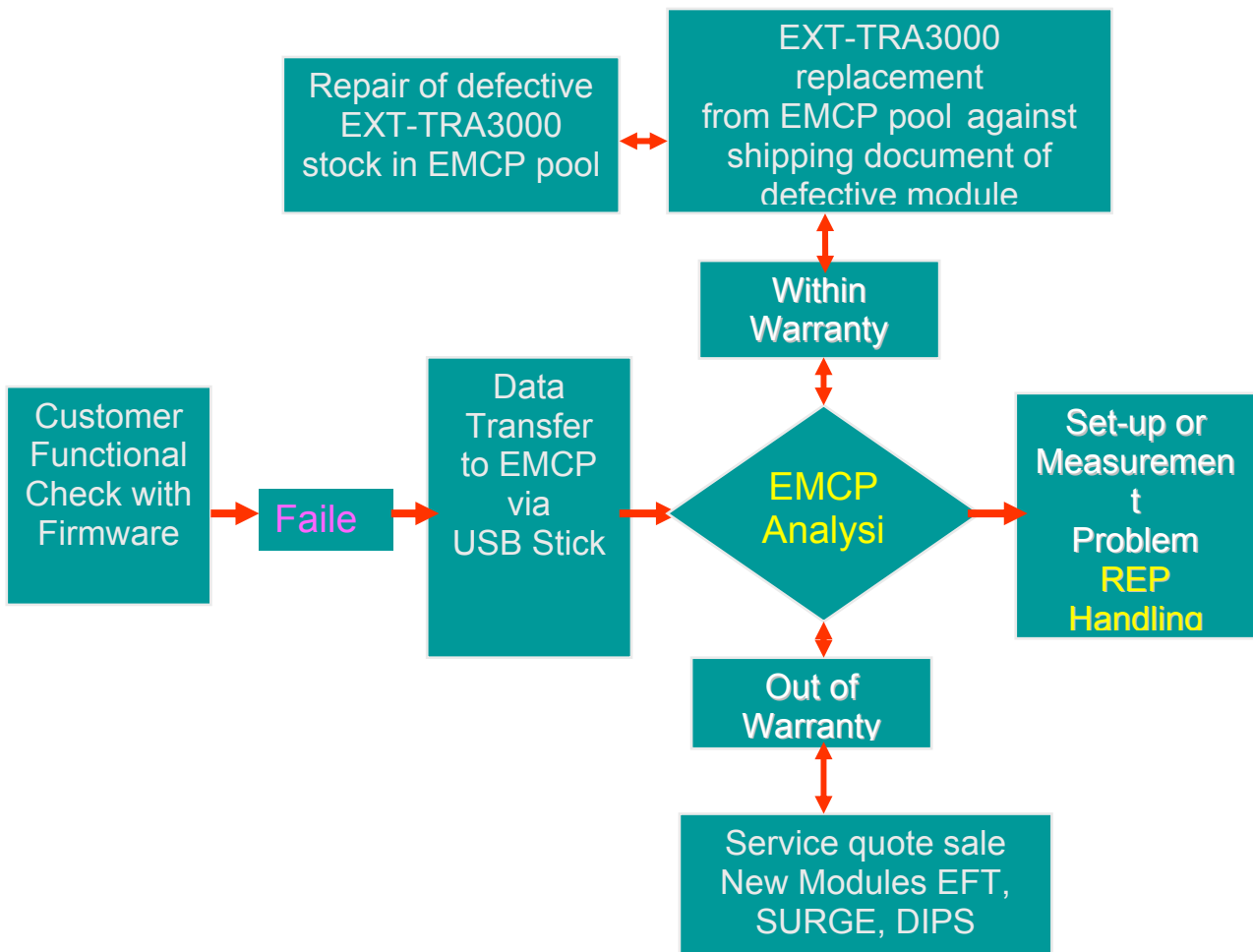

8.2.2 Data Transfer via UBS Stick

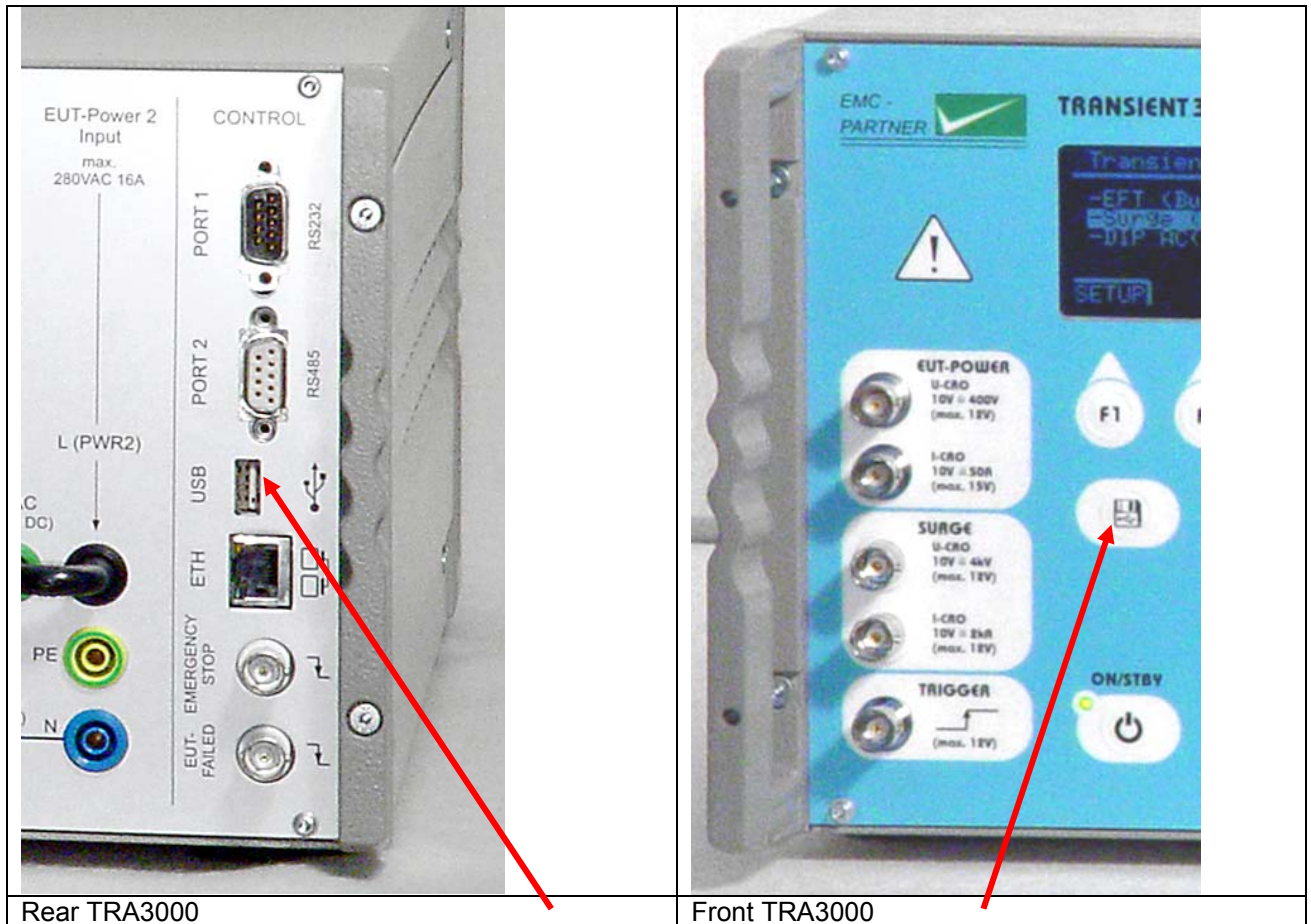

Rear TRA3000

Front TRA3000

- Step 1: Insert the USB stick
- Step 2: Select Service menu
- Step 3: Press USB button on the front
- Step 4: Send the data par email to EMC Partner

8.3 Spare parts list

No spare parts are necessary for the TRA3000 E-F-S-D-V-C.

8.4 Check before you contact the service of EMCP

8.4.1 Fuses

Always check the fuses of the unit before you contact EMCP service. A set of fuses has been delivered with the tester.

8.4.2 System Reset (Software)

A system reset can be performed in 3 different ways:

1. Reset with standby button, without deleting the stored test set-ups

- Press the standby button OFF and ON on the front panel
- The internal PC will be deactivated and activated
- The start up can take approx 15 s.
- When after 15 s the generator start up has not finished go to point 2

2. Reset via power button on the rear side of the TRA3000

- Turn OFF and ON the power button on the rear side
- Press the standby button on the front panel

3. Reset with keyboard button and load default set ups

When the following softkey has been pressed:

Main – Menu – Menu – Reset – Yes



display when "Main" has been pressed display after pressing twice Menu after pressing "RESET" button pressed

By pressing "YES" all stored set-ups will be deleted and changed to default set ups.

Putting out of operation

Whenever the TRA3000 E-F-S-D-V-C is not needed remove the power cord.

Reasons for putting the TRANSIENT out of operation:

- Install EXT-TRA3000 pcb
- Maintenance work
- Service, repair
- Calibration at EMC PARTNER
- Shipment for outdoor tests

The TRA3000 E-F-S-D-V-C is a laboratory test equipment. When the tester is not used, store it in a dry, clean dark place.

8.5 Service department of EMC PARTNER AG

EMC PARTNER AG
 Baselstrasse 160
 CH - 4242 Laufen
 Switzerland
 Tel. ++41 61 775 20 50
 Fax ++41 61 775 20 59
 Email service@emc-partner.ch
 Web www.emc-partner.com

9 Packaging and Transport

9.1 Packaging

If you transport the TRA3000 E-F-S-D-V-C, pack it in the original shipping box and packing material.

9.2 Transport

If you transport the TRA3000 E-F-S-D-V-C for outdoor EMC tests, the military box from EMC PARTNER is recommended.

If you are transporting the TRA3000 E-F-S-D-V-C to an EMC PARTNER field office for repair, attach a tag to the equipment showing the instrument owner and address, the name of the person to contact about the instrument, the instrument type and the serial number.

10 Recycling / Disposal

10.1 RoHS directive 2002/95/EG

The TRA3000 E-F-S-D-V-C generator complies with the directive 2002/95/EG (RoHS - Restriction of certain Hazardous Substances).

From December 2005, all EMC Partner products either hand soldered or by machine are produced using lead-free solder.

10.2 WEEE directive 2002/96/EG

The EMC Partner TRA3000 E-F-S-D-V-C generator, is exempted from the directive 2002/96/EG (WEEE) under category 9.

The product should be recycled through a professional organisation with appropriate experience for the disposal and recycling of electronic products. EMC Partner are also available to help with questions relating to the recycling of this product.

10.3 Information for dismantling



Always remove power cord first.

There is no special danger involved in dismantling the TRA3000 E-F-S-D-V-C.

10.4 Parts which can be recycled

The TRA3000 E-F-S-D-V-C contains parts made from steel, aluminium, PVC, two-component sealing compound. The impulse capacitors are filled with non-poisonous mineral oil. The various parts can be separated and recycled.

10.5 Parts which can not be recycled

All parts in the TRA3000 E-F-S-D-V-C can be recycled.

11 Accessories

11.1 TRA3000 E-F-S-D-V-C

11.1.1 Circuit extension to TRA3000

Pos.	Art.-No.	Type	Short Description
22	104028	EXT-TRA3000 C	TRA3000 Extension: Common Mode IEC 61000-4-16 Ed.1.2, up to 35V for all continuous a.c/d.c, frequency sweep up to 150kHz. Internal PCB. For short time test levels see accessories.
23	104123	EXT-TRA3000 C-SHORT	Extends TRA3000 C with short test. EXT-TRA3000 C-SHORT consists of one external trafo box, 1x PS3 power supply, 1x RS232/485 converter to remote control the PS3 from TRA3000. Requires TRA3000 C.
24	104026	EXT-TRA3000 D	TRA3000 Extension: DIPS IEC 61000-4-11 Ed.2. Interruption up to 16A. Internal PCB
25	104124	EXT-TRA3000 D-V-29D	Extension to TRA3000 for d.c. dips and interruption according to IEC 61000-4-29. Consist of: 2 x PS3, 2 x RS232/485 converter to remote control PS3 from TRA3000. Requires TRA3000 D.
26	104125	EXT-TRA3000 D-V-29I	Extension to TRA3000 for d.c. interruption according to IEC 61000-4-29. Consists of: 1 x PS3, 1 x RS232/485 converter to remote control PS3 from TRA3000. Requires TRA3000 D.
27	104023	EXT-TRA3000 E	TRA3000 Extension: Electro Static Discharge, IEC 61000-4-2 Ed.2 150pF, 330 Ohm. AD up to 16kV, CD up to 10kV. External accessory.
28	104024	EXT-TRA3000 F	TRA3000 Extension: Electric Fast Transient, IEC 61000-4-4 Ed.2 EFT (4.4kV), 1MHz burst. Internal PCB.
29	104027	EXT-TRA3000 S	TRA3000 Extension: SURGE IEC 61000-4-5 Ed.2 CWG 1.2/50µs (4.1kV), 8/20µs (2.05kA). Internal PCB.
30	104025	EXT-TRA3000 V	TRA3000 Extension: Voltage Variation up to 6A IEC 61000-4-11 Ed.1. Internal Variac.

11.1.2 CDN for Power supplies

The accessories of TRA2000 can be used also with TRA3000 F-S-D-V-C

Pos.	Art.-No.	Type	Short Description
48	103697	CDN16-450C	Single phase coupling decoupling filter for 115V, 400Hz to TRA2000 SURGE and EFT. Maximum current per phase 16A.
49	103475	CDN2000-06-32	Three phase CDN with line voltages L to N/PE=280V and L to L=415V, line current 32A per phase. Manual coupling path selection for EFT, SURGE and RING.
50	103477	CDN2000A-06-32	Three phase CDN with line voltages L to N/PE=280V and L to L=415V, line current 32A per phase. Automatic coupling path selection for EFT, SURGE and RING controlled by TRA2000, TRA2004, TRA2006, TRA3000 and MIG0603INx with SN > 199.
51	103695	CDN2000A-06-32 480V	3 phase CDN with line voltages L to N/PE=280V and L to L=480V, line current 32A per phase. Automatic coupling path selection for EFT, SURGE and RING controlled by TRA2000, TRA2004, TRA2006, TRA3000 and MIG0603INx with SN > 199.
52	103696	CDN2000A-06-32 CMC	3 phase CDN with line voltages L to N/PE=280V and L to L=480V, line current 32A per phase. Auto coupling path selection for EFT, SURGE, RING controlled by TRA2006 and MIG0603INx with S/N >199. Coupling path mode L1 + L2 + L3 + N to PE.

53	103582	CDN2000A-06-63	Three phase CDN with line voltages L to N/PE=280V and L to L=480V, line current 63A per phase. Automatic coupling path selection for EFT and SURGE controlled by TRA2000, TRA2004, TRA2006, TRA3000 and MIG0603INx with SN > 199.
54	104117	CDN-A-3P100-480 F	Three phase CDN with line voltages L to N/PE=280V and L to L=480V, line current 100A per phase. Automatic coupling path selection for EFT controlled by TRA2000, TRA2004, TRA2006 and TRA3000.
55	104116	CDN-A-3P100-480 F-S	Three phase CDN with line voltages L to N/PE=280V and L to L=480V, line current 100A per phase. Automatic coupling path selection for EFT and SURGE controlled by TRA2000, TRA2004, TRA2006, TRA3000 and MIG0603INx with SN > 199.
56	104119	CDN-A-3P100-690 F	Three phase CDN with line voltages L to N/PE=398V and L to L=690V, line current 100A per phase. Automatic coupling path selection for EFT controlled by customized TRA2000, TRA2004, TRA2006 and TRA3000. The generator must be ordered together with the CDN.
57	104118	CDN-A-3P100-690 F-S	Three phase CDN with line voltages L to N/PE=398V and L to L=690V, line current 100A/Phase. Automatic coupling path selection for EFT and SURGE controlled by customized TRA2000, TRA2004, TRA2006, TRA3000, and MIG0603INx with SN > 199. The generator must be ordered with CDN.
66	103699	DN2000-22-5	One Decoupling Module for IEC 60255-22-5 application. Inductance 20mH, varistor at the auxiliary side 275V, I _{max} continuous 3A, intermittent use 10mn 5A.

11.1.3 Power fail on power supplies

Pos.	Art.-No.	Type	Short Description
75	103670	PFS32	Extension of TRA2000 D and TRA3000 D. The PFS32 can generate interruptions on three phase power supply up to 480V/ 32A. For DIPS and supply configuration the PFS32 can be inserted in the SRC32 rack.
76	103675	PFS63	Extension of TRA2000 DIPS and TRA3000 D. The PFS63 can generate interruptions on 3 phase power supply up to 480V/ 63A. For DIPS and supply configuration the PFS63 can be inserted in the SRC63 rack.
77	103701	PFS75	Extension of TRA2000 D and TRA3000 D. The PFS75 can generate interruptions on 3 phase power supply up to 480V/ 75A. For DIPS and supply configuration the PFS75 can be inserted in the SRC75 rack.
78	103671	SRC32-18UH	18 Unit High rack with 3 phase transformer for 3 phase dips. The rack has enough space for inserting TRA2000 D, TRA3000 D, and PFS32 or PFS63. Minimum configuration: Generator with DIPS circuit and PFS32 or PFS63.
79	103700	SRC32-36UH	36 Unit High rack with 3 phase transformer for 3 phase dips. The rack has enough space for inserting TRA2004 or TRA2006 and PFS32 or PFS63. Minimum configuration: Generator with DIPS circuit and PFS32 or PFS63.
80	103676	SRC63	18 Unit High rack with 3 phase transformer for 3 phase dips. The rack has enough space for inserting TRA2000 D, TRA3000 D, and PFS63. Minimum configuration: Generator with DIPS circuit and PFS63.
81	103702	SRC75	Extension of PFS75. The SRC75 together with the PFS75 can generate interruptions and DIPS on 3 phase power supply up to 480V/ 75A.
83	103470	VAR-EXT1000	Extends a D with 16A external variac for DIPS and variation, complies fully with IEC 61000-4-11 Ed.2.

11.1.4 CDN for data lines

Pos.	Art.-No.	Type	Short Description
58	103471	CDN-KIT1000	SURGE coupling-decoupling network for data lines according to IEC 61000-4-5.
59	103538	CN16	Coupling network for common mode coupling dc, 50/60Hz and sinusoidal up to 150kHz according to IEC 61000-4-16.
60	103539	CN16T	T-coupling network for telecom lines coupling dc, 50/60Hz and sinusoidal up to 150kHz according to IEC 61000-4-16.
61	103698	CN2000-22-5	One Coupling Module. Serial resistor 40 Ohm and capacitor 0.5 μ F.
63	103579	CN-BALUN	Balanced / unbalanced transmission line transformer for EFT and 1MHz Damped Sine according to ANSI / IEEE C37.90.
64	103468	CN-EFT1000	Capacitive coupling clamp 100 Ohm according to IEC 61000-4-4 including 1m coax cable with BNC connectors.
74	103677	NW-TRA-RAIL	Discharge network to TRA or MIG with surge circuit for WF 5/50 μ s generation in accordance with IEC 60571, EN50155, RIA Spec 12 (1984). Maximum voltage approx. 3kV.

11.1.5 CN for current injections

Pos.	Art.-No.	Type	Short Description
62	103568	CN2000TT MC	One test pistol and one banana plugged cable with crocodile clip for current injection tests according to IEC 61000-4-5 up to 3kA. The test pistol can be used together with TRA and MIG systems with MC plug outputs on front panel or NW.

11.1.6 Items for calibration or verification

Pos.	Art.-No.	Type	Short Description
65	103643	DIPS100E	100 Ohm resistor for switching time calibration. Can be used with TRA1000, TRA2000, TRA3000, PFS32, PFS63. 100 Ohm +/-5%, 1 kW.
84	103473	VERI1K EFT	1kOhm termination with high voltage BNC and integrated divider for EFT calibration / verification.
85	103472	VERI50 EFT	50 Ohm termination with high voltage BNC connectors and integrated divider for EFT calibration / verification.
86	103474	VERI-DIPS	Measuring set for calibration / verification of the inrush current TRA1000, TRA2000xx, TRA3000, PFS32 and PFS63.

566

11.1.7 Items for test place set up

Pos.	Art.-No.	Type	Short Description
67	103658	EFT INSULATION	Set of 2 x 10cm Insulation to EFT circuit according to IEC 61000-4-4.
82	103486	TRA-Setup	Flexible connection TRANSIENT to EFT reference plate, 1m cable, 2 x 470kOhm banana socket.

11.1.8 Magnetic field tests

Pos.	Art.-No.	Type	Short Description
69	103480	MF1000-1	Test coil 1m x 1m for magnetic field test: 50/60Hz according to IEC 61000-4-8, SURGE according to IEC 61000-4-9, Damped oscillatory wave according to IEC 61000-4-10.
70	103481	MF1000-2	Test coil 1m x 2.6m for magnetic field test: 50/60Hz according to IEC 61000-4-8, SURGE according to IEC 61000-4-9, Damped oscillatory wave according to IEC 61000-4-10.
71	103482	MF1000-3	Test coil 1m x 1m for magnetic field test according to IEC 61000-4-8 only for short duration 3s 1000A/m.
72	103483	MF1STAND	Stand to MF1000-1, moveable in all three directions, max height 1.8m. Must be ordered together with the MF1000-1. Can only be shipped together with the MF1000-1.
73	103484	MF3STAND	Stand to MF1000-3, moveable in two directions, max. height 1.8m. Must be ordered together with the MF1000-3. Can only be shipped together with the MF1000-3.

11.1.9 Softwares

Pos.	Art.-No.	Type	Short Description
292	103057	TEMA	Test Manager (TEMA). Comfortable control of up to four gen as TRA2000, MIG2000 or ESD3000 systems: EUT control, test report and library. Each SN requires one "ENTRY CODE = one TEMA Software". Incl. connection cable 25/9 pole to PC.
293	103058	TEMA DSO CONTROL	TEMA Software: module for DSO (digital storage oscilloscope) "Extended" and "Option" codes necessary.

Demand a quote for calibration

All calibration reports include detailed measurement datas including oscillogramms.

12 Remote Ports

12.1 General

12.1.1 Ethernet port setting on TRA3000

The following steps must be carried out on TRA3000 to remote control from a local PC

Press "Main" - three time "Menu" - "Eth."



Set the Local IP to the TERA 3000 IP Address, example 192. 168. 0.140

12.1.2 IP address setting on PC

The following steps must be carried out to control the TRA3000 from a local PC

Open the network windows as shown below:

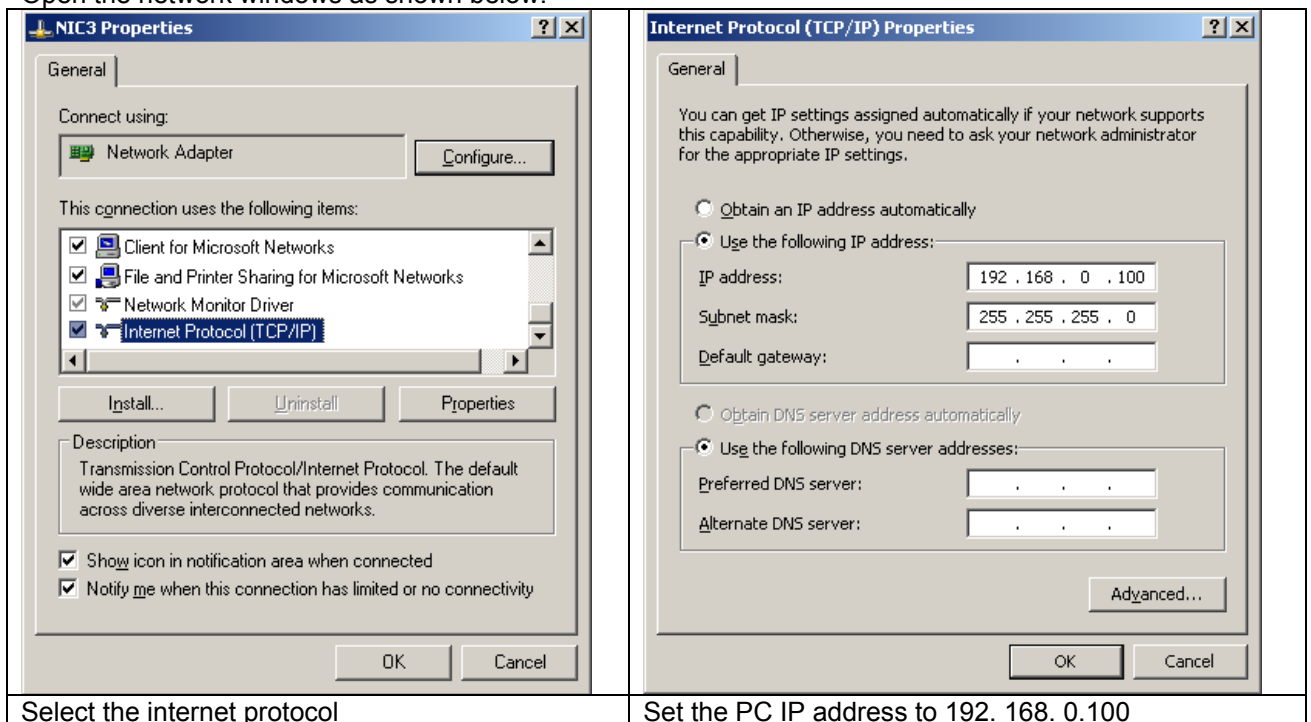

Connect with Ethernet cable type (crosswire) delivered with the TRA3000 standard accessories the PC to the TRA3000.

When the GENECS is installed on the PC, then the TRA3000 can be remote controlled from the PC.

For Web server access, start your web browser (internet explorer, Morzilla, Firefox,...) and write the TRA3000 IP address. Example: http://192.168.0.140

12.1.3 Technical Data of the RS 232C serial port

The TRA3000 E-F-S-D-V-C remote-control option enables remote control of the TRA3000 E-F-S-D-V-C via the RS-232 serial port.

The V.24 serial port uses the data lines TxD and RxD for the information transfer.

Baudrate: 1200, 4800, 9600, 19200, **115200**
 Databits: **7, 8**
 Parity: **None**, Even, Odd
 Stop: **1, 2**
 Protocol: **None**
 End of sequence: **CR, LF, CR+LF**

With the pinning below the remote control of a TRA3000 E-F-S-D-V-C generator is guaranteed.

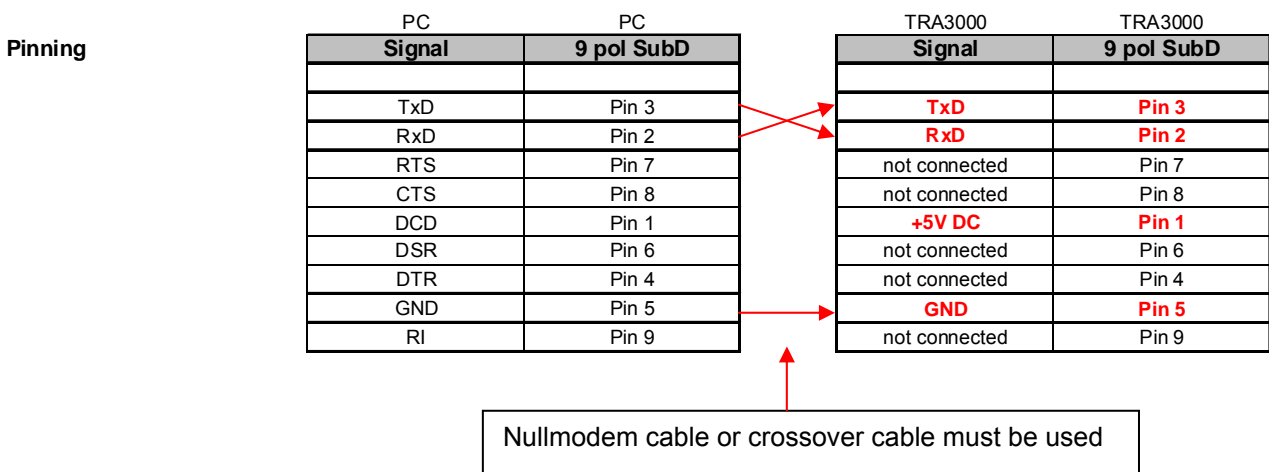

Modification of the configuration values can be carried out using the keyboard in the menu Remote Control Set-up. The remote-control-set-up menu is in the general menu.

12.1.4 Local or Remote Control

The function local or remote can be selected with the external system controller. Two conditions can be selected:

- Local (process is controlled by the TRA3000 E-F-S-D-V-C controller)
- Remote (process is controlled by the external controller e.g. PC)

After turning on the TRA3000 E-F-S-D-V-C the status of the generator is „local“. Only commands selected by the operator using the keyboard are accepted. The system controller commands are blocked.

The generator changes from the condition "local" to "remote" when the Command "REN" (Remote Enable) has been received from the system controller e.g. PC.

12.1.5 Remote Control

In this operation mode, the TRA3000 E-F-S-D-V-C can only be controlled by the external system controller e. g. PC.

A reset to the condition "local" can be made from the system controller by sending a "GTL" Command (Go To Local), by turning the power of the generator OFF and ON or by pressing the buttons RUN, Power ON/OFF.

12.2 Organisation of TRA3000 E-F-S-D-V-C Remote-Control Commands

12.2.1 Syntax of the Commands

12.2.1.1 Separation signs:

Within a command, or when limiting a command or ending a command block the following signs must be used:

- < > space after the header command
- < ; > ending a command within a command block
- <EOS> Closing the command block (End Of Sequence) :

12.2.1.2 Commands Format

Integer	positive number in the range 0 to 29999, transmitted as an ASCII-string. The units and the formats correspond to inputs/outputs in the TRA3000 E-F-S-D-V-C-display.
Real	floating decimal point in the format .xxx to xxx. without an exponent, transmitted as ASCII-string. The units and the format correspond to the inputs/outputs in the TRA3000 E-F-S-D-V-C-display
Character	sequence of letter and numbers

12.2.2 Set-up Commands:

Set-up commands consist of the following three parts:

<set command>=<head>< ><argument>

<head> Sequence of 2 to 4 ASCII-characters 'A'..'Z'; 'a'..'z' as start of a command. It will not differ between capital and small letters.

< > Separation sign between <head> and <argument>

<argument> argument, in form of a integer-, real- or a sequence of numbers. No difference is made between capital and small letters.

Example: VNOM 2000<EOS> or POL POS<EOS>

Several commands can be reduced to single command, and be terminated with the sign <EOS>. Single command are separated by semicolons:

<set command> { ; <set command> }... <EOS>

Example: VNOM 4000;POL NEG;Rep 10<EOS>

12.2.3 Inquire Commands

Inquire commands start TRA3000 E-F-S-D-V-C transmitting internal data to the system controller. The data consists of two parts:

<Inquire commands>=<head>{< >}<?>

Instead of the argument, a question mark is used in Inquire Commands. A command contains a maximum of one Inquire Command which must be located at the end of the command. On the other hand several set-up Commands are allowed:

Examples:

Based on the Inquire Command ...
the following answer can occur:

VNOM ?<EOS>
2000

or: controller:
TRA:

POL?<EOS>
NEG

or: controller:
TRA:

VNOM 1000;E?<EOS>
0

12.2.4 Failure messages remote control:

```

Remote Mode | USB disconnected
-----|-----
Command:    | Description:
10H50:TST fake | Invalid argument.
10H50:AUX?   | Invalid argument.
10H50:FAKE   | Unknown header
10H50:REN   | OK
10H50:GTL   | OK
    
```

Error Message	"E?" remote answer	Description
"OK"	'0'	No error.
"Unknown header"	':'	Unknown command.
"Invalid argument"	'3'	Invalid parameter.
"Query expected"	'4'	No query in message as expected.
"Only on local mode"	'l'	Must "GTL" before.
"Only on remote mode"	'r'	Must "REN" before.
"Only on RUN mode"	'R'	Only when start a test.
"Not in RUN mode"	'N'	Only in standby mode.
"Empty"	'e'	No argument in message as expected.

12.3 Remote Control Command set

Command **TST** (TeST)

Explanation: set or query the test mode.

Arguments: *characters* IMP1, IMP2, IMP3....., IMP11

Example: TST IMP1

This command must be used at a generator with different wave shapes.

Command **VNOM** (Voltage NOMinal)

Set or query V-peak [in V]

Argument: *Integer*
0..Vmax resp. 0..110 of DIP

Example: VNOM 1500

VNOM?
Answer: 1500

Command **POL** (POLarity)

Explanation: Set or query the Polarity.

Argument: *Characters* POS, NEG

Example: VNOM 1500
POL NEG

Command **REP** (REPetition)

Explanation: depends on the type of test:

Argument: *Integer*

Example: VNOM 1500
POL NEG
REP 10

Command **NBR** (NumBeR)

Explanation: depends on the type of test:

Argument: *Integer* 0..30000

Example: NBR 10

Command TRIG (TRIGger)

Explanation:

Set or query **Trigger Mode**.

Argument: *Characters* AUTO, MAN

Example: TRIG MAN

TRIG?

Answer: MAN

Command SYF (SYncro Frequency)

Explanation: Set or query Syncro Frequency (fundamental frequency).

Argument: *Characters* F1 correspond 16 Hz
 F2 corresponds 40 Hz
 F3 corresponds 50 Hz
 F4 corresponds 60 Hz
 F5 corresponds 400 Hz

Example: SYM ON
 SYF F3
 SYA 180

Command SYA (SYncro Angle)

Explanation: Set or query **Syncro Angle** [in degrees].

Argument: Integer 0..360

Example: SYM
 SYA 180

Command DEF (DEFaults)

Explanation: All parameter will be resetted to the default values.

Argument: no argument

Command PON (Power ON)

Explanation:

Turn on/off the **EUT power**, or query the condition of the EUT power e. g. voltage value. These command is only useful with automatic external CDN.

Argument: *Integer* 0,1,2

Example: (50Hz)
 PON 1 (turn on the EUT power on PWR1)
 PON?
 Answer: 1
 PON 0F (turn off the EUT power)

Command EUT (EUT failed action)

Explanation: Set or query Action if EUT failed.

Argument: *Characters*

Example: IMAX 500;EUT

Command VMAX (Voltage MAX)

Explanation: Set or query EUT failed Limit, Surge Voltage max. [in V].

Argument: *Integer 0..9999*

Example: VMAX 600;VMIN 300;EUT

Command VMIN (Voltage MIN)

Explanation: Set or query EUT failed Limit, Surge Voltage min [in V]

Argument: *Integer 0..9999*

Command IMAX (current MAX)

Explanation: Set or query EUT failed Limit, Surge Current max. [in A]

Argument: *Integer 0..9999*

Example: IMAX 500;IMIN 300;EUT INFO

Command IMIN (current MIN)

Explanation: Set or query EUT failed, Surge Current min [in A].

Argument: *Integer 0..9999*

Command BTR (Beep on TRigger)

Explanation: Set or query Beep on Trigger.

Argument: *Characters* ON, OFF

Example: BTR?
Answer: ON

Command BOF (Beep On Failed)

Explanation: Set or query Beep on Failed

Argument: *Characters* ON, OFF

Example: BOF ON

Command STOP (STOP run)

Explanation: Interrupts the Run-Mode.

No query possible. Run-Mode can be recognised by the command ST?..

Argument: no argument

Example: START
 ST?
 Answer: R (Generator is in Run-Mode)
 STOP
 Answer: S (Generator is in standby-Mode)

Command STRT (STaRT run)

Explanation: Start of the Run-Mode.

No query possible. Run-Mode can be recognised by the command ST?..

Argument: no argument

Example: **START**
 ST?
 Answer: R (Generator is in Run-Mode)
 STOP
 ST?
 Answer: S (Generator is in Standby-Mode)

Command PAU (PAUse)

Explanation: Set or query the condition pause

Argument: *Characters* ON, OFF

Example: START
 PAU ON

Command IT (Initiate Trigger)

Explanation: Trigger with the same function as the trigger button on the front panel of the TRA3000 E-F-S-D-V-C

The trigger mode manual must be chosen (TRIG=MAN).

No query possible.

Argument: n o argument

Example: TRIG MAN
 START
 ...
 IT (Trigger of the pulses)

Command ST (generator SStatus)

Explanation: query of Generator Status .

Argument: no argument

Answer: Characters have the following meanings:
S : Standby
B : Busy (e.g. during charging process)
R : Run-Mode

Example: START
ST?
Answer: R (Generator in Run-Mode)
STOP
ST?
Answer: S (Generator in Standby-Mode)

Command LN (Last Number)

Explanation: query of the last pulses

Argument: no argument

Answer: Integer

Example: LN?
Answer: 5

Command LV (Last Voltage)

Explanation: query of the current voltage [in V] or. Level [in %] at ramps.

Argument: no argument

Answer: Integer

Example: LV?
Answer: +2100

Command LS (Last Syncro)

Explanation: query of the current syncro angle [in degrees] at ramps.

Argument: no argument

Answer: Integer 0..360

Example: LS?
Answer: 190

Command LC (Last Coupling)

Explanation: query of the current coupling paths. Only with external automatic CDN relevant

Argument: no argument

Answer: Characters
IMP-OUT, L-N, L-PE, N-PE

Example: LC?
Answer: IMP-OUT

Command VPK (Voltage Peak)

Explanation: query of the Surge voltage peak measurement [in V] of the last pulse.

Argument: no argument

Answer: Integer 0..5000

Example: VPK?
Answer: 2345 (positive Impulse)
or Answer: -2100 (negative Impulse)

Command IPK (current Peak)

Explanation: query of the Surge peak current measurement [in A] of the last pulse.

Argument: no argument

Answer: Integer 0..2500

Example: IPK?
Answer: 1345 (positive Impulse)
or Answer: -1100 (negative Impulse)

Command ID (IDentification)

Explanation: Inquiry of the type of equipment.

Argument: no argument

Answer: Characters : TRA v.vv
v.vv stays for the software version

Example: ID?
Answer: TRA 1.15

Command ID (Full IDentification)

Explanation: Inquiry of the type of equipment.

Example: FID?
Answer: TRA3000 F-S-D-V

Command REN (REmote Enable)

Explanation: change-over into Remote Control Mode.
No query possible

Argument: no argument

Command GTL (Go To Local)

Explanation: change-over into Local Mode. (manipulation from the TRA front panel)
No query possible

Argument: no argument

Command E (Error number)

Explanation: query of Remote Error-Code.
The remote error-code will be reset by the command E?

Argument: no argument

Answer: Integer with the follow codes
0: no error

- 1: Command only allowed in remote
- 2: unknown command
- 3: impermissible argument
- 4: no query allowed
- 5: command only allowed in standby-mode
- 8: timeout at transmitting end
- 16: parity error at transmitting end
- 32: overflow of the input buffer
- 64: other errors

Error-Code 1 to.5 always relate in any case to the preceding command.
The Error-Code will be reset after each query.

Example: VNOM 4ç*6
E?
Answer: 3

12.4 Overview of TRA3000 E-F-S-D-V-C Commands

TRANSIENT-3000 Remote Control Commands - v1.00 – 22/02/2010

=====

For each parameter referred by a string in menu, it is possible to give the string as command parameter, without case sensitivity.

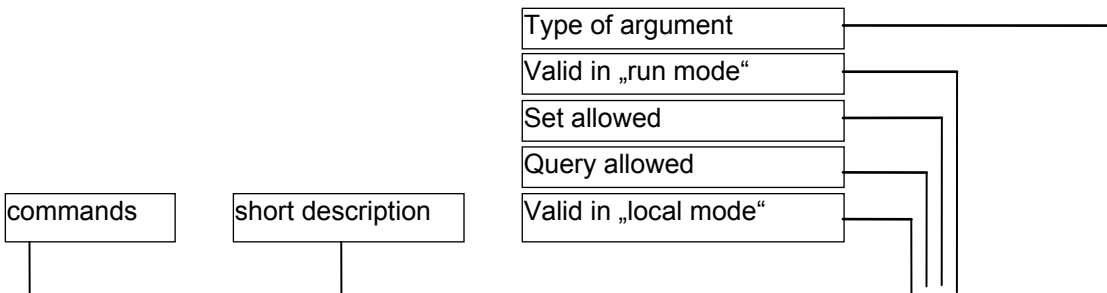

Main Parameters:

TST	Test Kind	.xx.	EFT, ESD, SURGE DIPAC, DIPDC, VAR, MF, CM
-----	-----------	------	---

ESD

VNOM	V-charge resp. V-peak (in V)	.xx.	Integer
POL	Polarity	.xx.	Pos, Neg
NBR	Number of Pulses	.xx.	Integer
REP	Repetition (in msec)	.xx.	Integer
TRIG	Trigger Mode	.xx.	Auto, Man
MO	0=Every Pulse, 1=On Discharge only	.xx.	Integer or string
MD	Discharge mode	.xx.	Air, Contact, Firing

EFT

VNOM	V-charge resp. V-peak (in V)	.xx.	Integer
POL	Polarity	.xx.	Pos, Neg
TTM	Test-Time (in sec)	.xx.	Integer
ESF	Spikes Frequency (in KHz)	.xx.	Integer
EBD	Burst Duration (in ms)	.xx.	Integer
SYM	Syncro Mode	.xx.	Off, Power, Extern
SYA	Syncro Angle (in Deg.)	.xx.	Integer
REP	Repetition (in msec)	.xx.	Integer
TRIG	Trigger Mode	.xx.	Auto, Man
MD	Random-Mode	.xx.	On, Off

SURGE

VNOM	V-charge resp. V-peak (in V)	.xx.	Integer
POL	Polarity	.xx.	Pos, Neg
NBR	Number of Pulses	.xx.	Integer
REP	Repetition (in sec)	.xx.	Integer
TRIG	Trigger Mode	.xx.	Auto, Man
SYM	Syncro Mode	.xx.	Off, Power, Output, Extern
SYA	Syncro Angle (in Deg.)	.xx.	Integer
MO	0=CWG 1=MF-1000-1, 2=MF-1000-2	.xx.	Integer or string

DIPAC

VNOM	Dip Level (in %)	.xx.	Integer
------	------------------	------	---------

EMC PARTNER AG

NBR	Number of Periods or Dip Duration (in msec)	.xx.	Integer
REP	Repetition (in sec)	.xx.	Integer
TTM	Test-Time (in sec)	.xx.	Integer
TRIG	Trigger Mode	.xx.	Auto,Man
MO	0="< 1 Period", 1="> 1 Period", 2="Option 3.2"	.xx.	Integer or string
MD	High-Z at 0%	.xx.	On,Off
D1B	DIP: Dip1 Begin (in Deg.)	.xx.	Integer
D2B	DIP: Dip2 Begin (in Deg.)	.xx.	Integer
D1E	DIP: Dip1 End (in Deg.)	.xx.	Integer
D2E	DIP: Dip2 End (in Deg.)	.xx.	Integer
D2S	DIP: Dip2 selection	.xx.	on,off

DIPDC

VNOM	Dip Level (in %)	.xx.	Integer
NBR	Dip Duration (in msec)	.xx.	Integer
REP	Repetition (in sec)	.xx.	Integer
TTM	Test-Time (in sec)	.xx.	Integer
TRIG	Trigger Mode	.xx.	Auto,Man
MO	0="Short Int."	.xx.	Integer or string
MD	High-Z at 0%	.xx.	On,Off

VAR

VNOM	Nominal Voltage for adjust (in V)	.xx.	Integer
VATN	Variation tn (in s)	.xx.	Integer
VAMD	Variation td mode	.xx.	abrupt, adjust
VATD	Variation td (period)	.xx.	Integer
VATS	Variation ts (period)	.xx.	Integer
VAL	Variation Level (in %)	.xx.	Integer
VATI	Variation ti (period)	.xx.	Integer
NBR	Number of Cycles	.xx.	Integer

MF

VNOM	MF Level (in A/m)	.xx.	Integer
TTM	Test-Time (in sec)	.xx.	Integer
MO	0=MF1000-1, 1=MF1000-2, 2=MF1000-3, 3=special	.xx.	Integer or string

CM

VNOM	Nominal Voltage (in V)	.xx.	Integer
NBR	Duration (in sec)	.xx.	Integer
REP	Repetition (in sec)	.xx.	Integer
TTM	Test-Time (in sec)	.xx.	Integer
TRIG	Trigger Mode	.xx.	Auto,Man
MD	Freq. Range Frequency unit: "Hz", "kHz"	.xx.	String
ESF	Freq. Range Frequency (in Hz or kHz, see MD)	.xx.	Integer
EBD	Mains Frequency: "DC", "16.7Hz", "50Hz", "60Hz"	.xx.	String
MO	CM Test: "Mains Freq", "Freq. Range"	.xx.	String
MO2	Mains Freq disturbance: "Short", "Continuous"	.xx.	String
MO3	Freq. Range mode: "Fix", "Sweep"	.xx.	String

Coupling:

EFT

CTO	"Impulse-Out", "EUT-Power", "CDN-3phase"	.xx.	String
CL	EUT-Power: Coupling to L	.xx.	On,Off
CN	EUT-Power: Coupling to N	.xx.	On,Off
CP	EUT-Power: Coupling to PE	.xx.	On,Off
CLN	EUT-Power: Coupling to L,N	.xx.	On,Off
CLP	EUT-Power: Coupling to L,P	.xx.	On,Off
CNP	EUT-Power: Coupling to N,PE	.xx.	On,Off
CLNP	EUT-Power: Coupling to L,N,PE	.xx.	On,Off
CL1N	CDN-3phase: Coupling to L1	.xx.	On,Off
CL2N	CDN-3phase: Coupling to L2	.xx.	On,Off
CL3N	CDN-3phase: Coupling to L3	.xx.	On,Off
CN3	CDN-3phase: Coupling to N	.xx.	On,Off
CP3	CDN-3phase: Coupling to PE	.xx.	On,Off

11BRemote Ports

CNP3	CDN-3phase: Coupling to N,PE	.xx.	On,Off
COAL	CDN-3phase: Coupling to L1,L2,L3,N,PE	.xx.	On,Off

SURGE

CTO	"Impulse-Out", "EUT-Power", "CDN-3phase"	.xx.	String
CL	EUT-Power: 2xVpeak for L-PE, N-PE	.xx.	On,Off
CLN	EUT-Power: Coupling to L-N	.xx.	On,Off
CLP	EUT-Power: Coupling to L-PE	.xx.	On,Off
CNP	EUT-Power: Coupling to N-PE	.xx.	On,Off
CL12	CDN-3phase: Coupling to L1-L2	.xx.	On,Off
CL13	CDN-3phase: Coupling to L1-L3	.xx.	On,Off
CL23	CDN-3phase: Coupling to L2-L3	.xx.	On,Off
CL1N	CDN-3phase: Coupling to L1-N	.xx.	On,Off
CL2N	CDN-3phase: Coupling to L2-N	.xx.	On,Off
CL3N	CDN-3phase: Coupling to L3-N	.xx.	On,Off
CL1P	CDN-3phase: Coupling to L1-PE	.xx.	On,Off
CL2P	CDN-3phase: Coupling to L2-PE	.xx.	On,Off
CL3P	CDN-3phase: Coupling to L3-PE	.xx.	On,Off
CNP3	CDN-3phase: Coupling to N-PE	.xx.	On,Off

DIP AC

CTO	DIPAC: "EUT-Power", "PFS", "PFS-SRC"	.xx.	String
CL1N	PFS: DIP on L1	.xx.	On,Off
CL2N	PFS: DIP on L2	.xx.	On,Off
CL3N	PFS: DIP on L3	.xx.	On,Off
COAL	PFS: DIP on L1,L2,L3	.xx.	On,Off
CL12	SRC: DIP L1 L2	.xx.	On,Off
CL13	SRC: DIP L1 L3	.xx.	On,Off
CL23	SRC: DIP L2 L3	.xx.	On,Off

Power Control:

PON	EUT Power OFF/PWR1/PWR2	.xxx	0,1,2
PSV	Set Variac to voltage (in V)	.xx.	Integer
PONS	EUT Power ON Syncro (in Deg.)	.xx.	Integer
POFS	EUT Power OFF Syncro (in Deg.)	.xx.	Integer
POCL	EUT Power Current Limit	.xxx	Integer
PO1	EUT Power 1 selection	.xx.	No,Main,PS3
PO2	EUT Power 2 selection	.xx.	No,Main, Variac,PS3
POA	EUT Power auto	.xx.	on,off
POAB	EUT Power auto before test (in min.)	.xx.	Integer
POAA	EUT Power auto after test (in min.)	.xx.	Integer
PS10	PS3 output on PWR1: "230V/50Hz", "230V/16.7Hz", "115V/60Hz", "115V/400Hz", "DC"	.xx.	String
PS20	PS3 output on PWR2	.xx.	String
PS1V	PS3 DC voltage on PWR1 (in V)	.xx.	Integer
PS2V	PS3 DC voltage on PWR2 (in V)	.xx.	Integer
PS1I	PS3 ID on PWR1	.xx.	Integer
PS2I	PS3 ID on PWR2	.xx.	Integer
VAS	Variac selection: "Intern", "Extern"	.xx.	String

Ramps:

RAK	Ramp Kind N: No ramp V: V-Peak / V-Charge / Level F: Spike Freq D: Burst Dur. / Duration S: Syncro Deg P: Polarity B: Dip Begin E: Dip End	.xx.	N, V, S, P, F, D, B, E
RAST	EFT,ESD,SURGE,DIP: Ramp Start (not for polarity)	.xx.	Integer/float
RASP	EFT,ESD,SURGE,DIP: Ramp Stop (not for polarity)	.xx.	Integer/float
RASE	ESD,SURGE,DIP: Ramp Step (not for polarity)	.xx.	Integer/float
RACA	Change after	.xx.	Integer
RATM	EFT: Ramp Time (in sec)	.xx.	Integer
SPB	EFT: Spikes per Burst , for F Ramp	.xx.	Integer

EUT Control:

EUT	Action if EUT Failed	.xx.	Info,Next,Stop
VMAX	Failed Limit: Surge Max.Voltage (in V)	.xx.	Integer
VMIN	Failed Limit: Surge Min.Voltage (in V)	.xx.	Integer
IMAX	Failed Limit: Surge Max.Current (in A)	.xx.	Integer
IMIN	Failed Limit: Surge Min.Current (in A)	.xx.	Integer

Setup:

SETS	Store Setup	..x.	String [15]
SETR	Recall Setup	..x.	String [15] (old) 'TAB(0x09)' String [15] (new)
SETD	Delete Setup	..x.	String [15]
SETL	Load Setup	..x.	String [15]
SETM	Setup Media	.xx.	usb,intern

General Parameters:

BTR	Beep on Trigger	.xx.	On,Off
BOF	Beep on Failed	.xx.	On,Off
CONA	Company name	.xx.	String [40max]
OPNA	Operator name	.xx.	String [40max]
EUTD	EUT description	.xx.	String [40max]
EUTS	EUT Serial Number	.xx.	String [40max]
EUTC	EUT Comments	.xx.	String [40max]
LRN	Test parameters	xxx.	"current_test"; String [1000max]

Generator Control:

STOP	Stop RUN	..xx
STRT	Start RUN	..x.
IT	Initiate Trigger	..xx

Generator Supervision:

M	Generator Error Message Number (Integer)	xx.x
ST	Actual Status of Generator (S,B,R)	.x.x
LN	Surge: Number of last Pulse (Integer)	.x.x
LV	Surge: Nominal Voltage of last Pulse (in V)	.x.x
LS	Surge: Syncro of last Pulse (in Degree)	.x.x
LC	Surge: Coupling of last Pulse	.x.x

Measuring:

VPK	Surge: Peak Voltage of last Pulse (in V)	.x.x
IPK	Surge: Peak Current of last Pulse (in A)	.x.x

11BRemote Ports

V	Power Voltage RMS (in V, Integer)	.x.x
I	Power Current RMS (in A, Real)	.x.x

"Remote Mode" Control:

ID	Identify System and Version	xx..
IDN	Identify System and Version=ID	xx..
FID	Full System Name	xx..
REN	Go to Remote Mode	x.x.
GTL	Go to Local Mode	..x.
E	Get Communication Error Code (Byte)	xx.x
SIN	Get serial number	xx..
DELP	Delete protocols in memory(not recommended)	xx..

12.5 Software "GENECS" for TRA3000 E-F-S-D-V-C Remote Control

The GENECS software delivered on a CD (the CD can be found in the cover of the calibration report binder), can be used to control the TRA3000 E-F-S-D-V-C via the Ethernet port.

12.5.1 Setup GENECS

See instruction on the CD. Follow the instruction of the installer program. When the GENECS is installed and the TRA3000 E-F-S-D-V-C connected via the Ethernet cable (Art Nr. 104537, patch cord cat. 5e FTP type crossover to CTRL3000, red, 3m), the display of the TRA3000 E-F-S-D-V-C and the display of the GENECS must show the same figure.

12.5.2 GENECS Windows

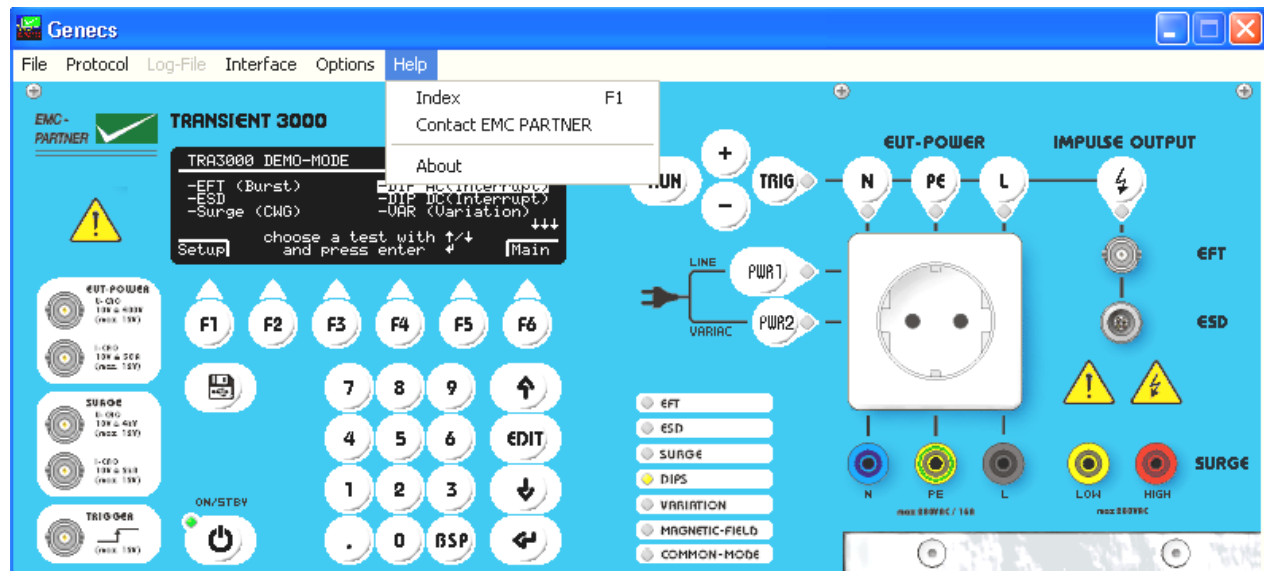

The GENECS windows is identical to the TRA3000 E-F-S-D-V-C front plate. Online the TRA3000 E-F-S-D-V-C can be remote controlled by pressing the buttons with the mouse cursor as on the real front plate.

Detailed information can be obtained from the "help index".

12.5.3 GENECS Library



In the file pull down menu press "open" and activate Library. The Library includes all test specified in the relevant basic and generic standards.

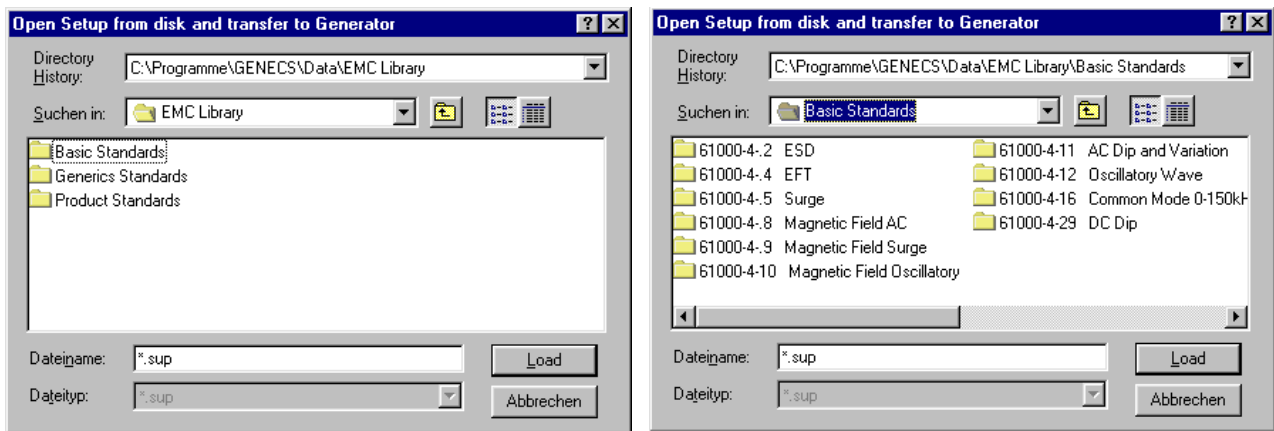

with "Load" the tests are loaded into the TRA3000 E-F-S-D-V-C. During the loading process a pointer indicator shows the loading status.

- Save test:** Saves a test in a test place 1 to 200
- Save Set-up:** Saves all 1 to 200 tests. 200 tests is equal a set-up
- Delete all test:** Deletes all 1 to 200 tests in the TRA3000 E-F-S-D-V-C

12.5.4 GENECS Protocol possibilities

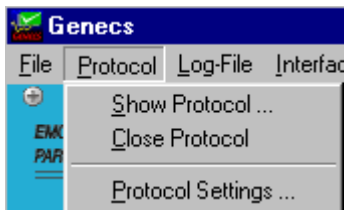

Show Protocol: Protocol can be opened as set

Close Protocol: Closes the protocol

Protocol setting: For each test the EUT operator etc. can be defined. The header of the test report will include the protocol setting

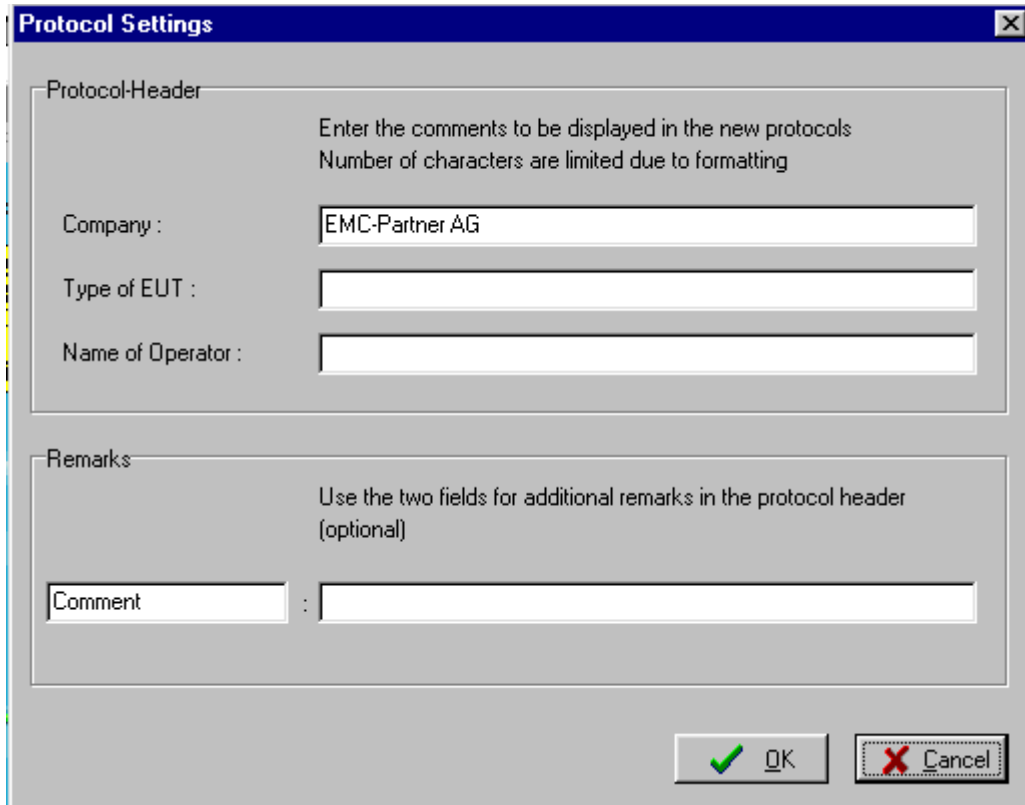

12.5.5 GENECS Log File

The log file automatically summarises the test results with the most important parameters.

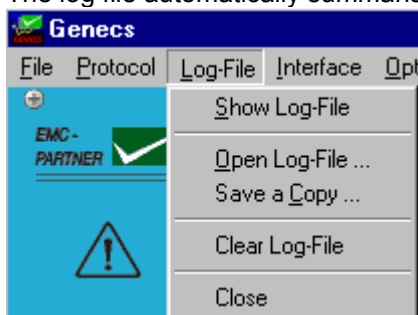

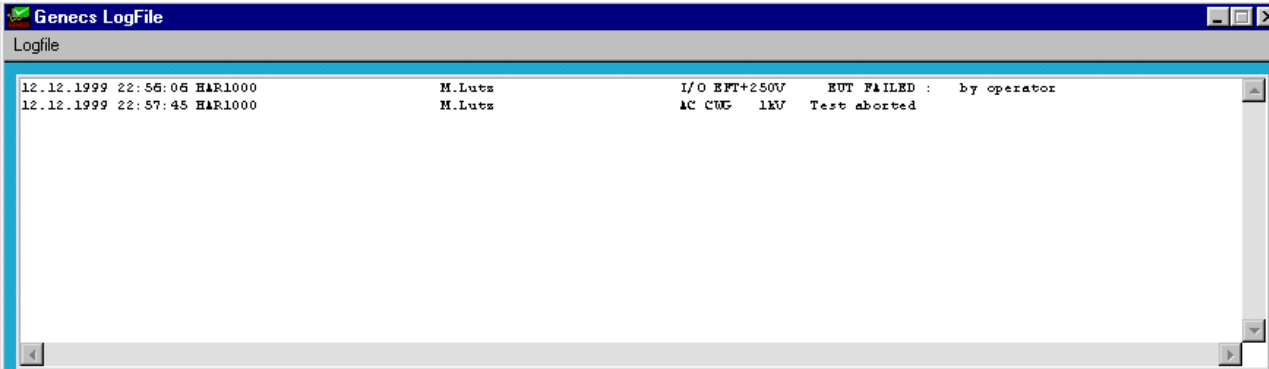

all started tests will be stored. With "Clear LogFile all stored tests are deleted.

12.5.6 GENECS Preferences

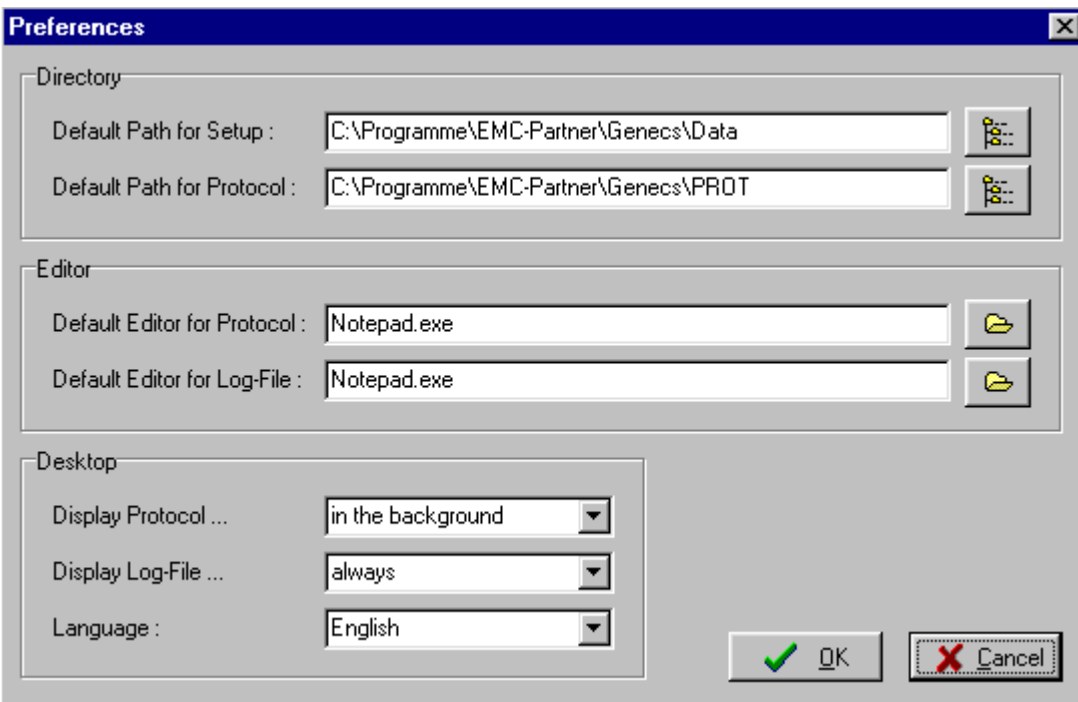

Default Editor for Protocols:

With the button ... a text program on your computer can be activated and automatically the test report will be loaded into this program. e.g. Word

Default Editor for LogFile:

With the button ... a data bank or calculation program on your computer can be activated and automatically the data will be loaded into this program. e.g. Access or Excel

Display LogFile:
it

When the logfile is not necessary on the monitor can be turned off. The Log file can be loaded with open logfile.

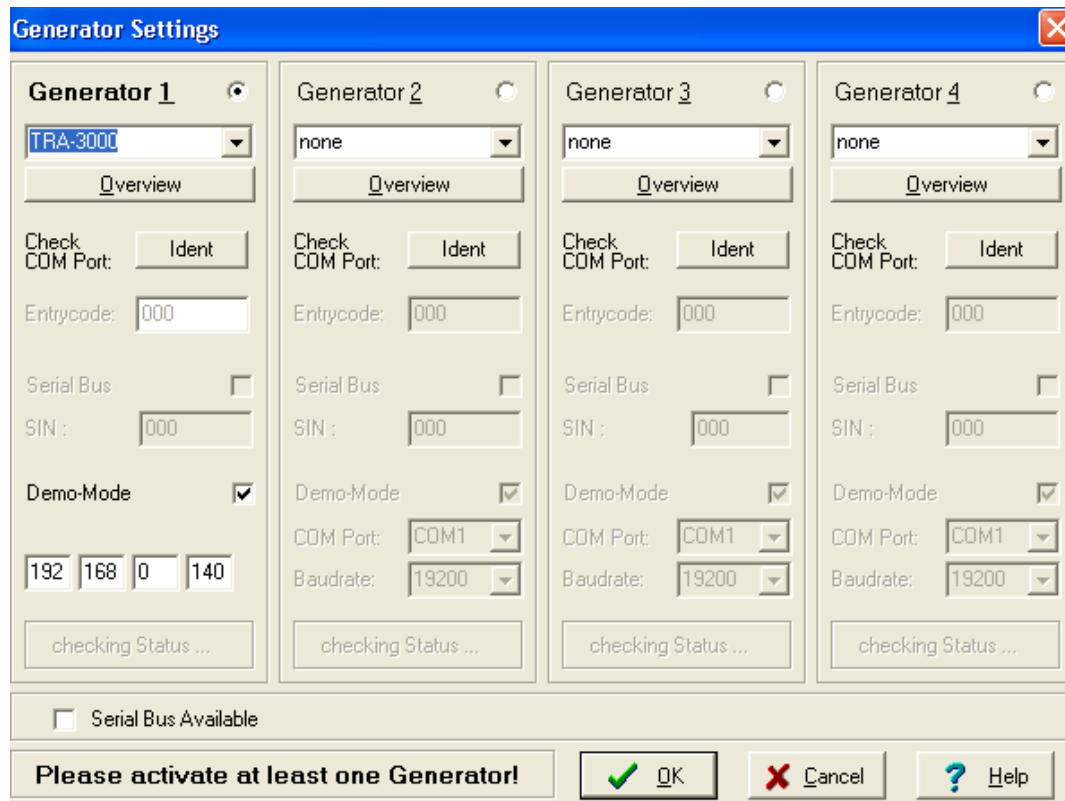

All Generators of EMCP can be loaded and demonstrated.

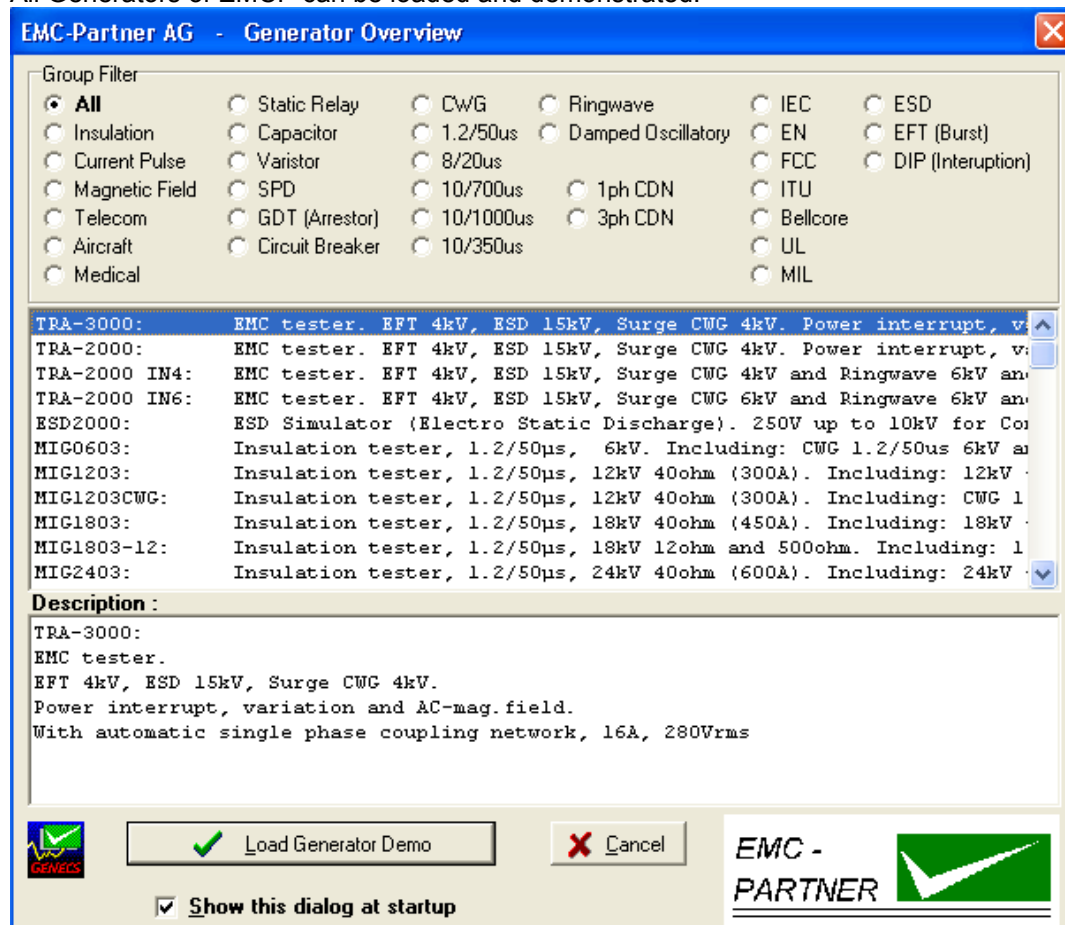

13 Appendix and Corrections

13.1 Appendix

13.1.1 Definition of the EFT Waveform

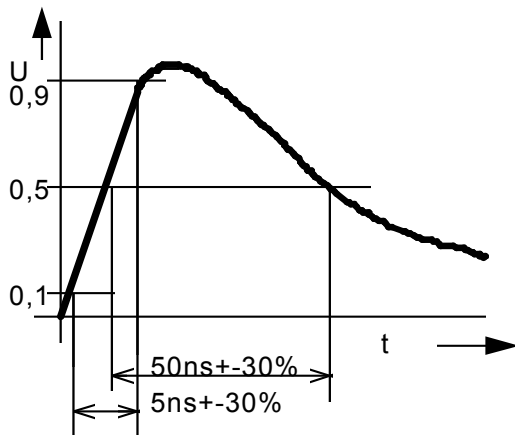

a) Spannungsform gemessen an 50 Ohm
Waveform measured at 50 Ohm

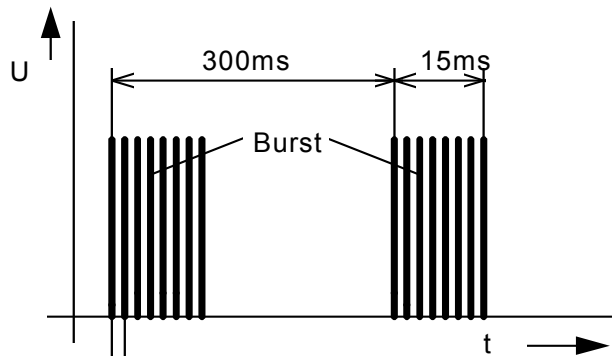

b) Burst Prüfsequenz
Burst test sequence
Abhängig von der Prüfspannung
depends on spike frequency

IEC 61000-4-4-Ed.2 specifies a verification of the waveform at 1000 Ohm

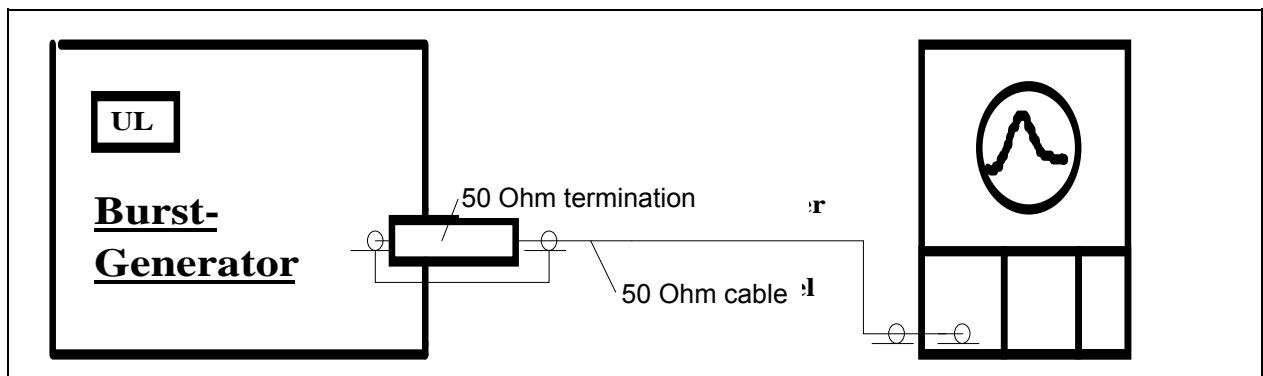

Memory oscilloscope
50 Ohm input

Checking the EFT tester. Checking procedure

1. The 50 Ohms terminating resistor, including the voltage divider, must be examined with a sinusoidal voltage (CW) between 100 kHz and 200 MHz
2. The rise time must be between 3.5 and 6.5 ns.
3. The time to half value must be between 35 and 65 ns.
4. The source impedance of the tester is 50 Ohm, providing the coefficient of $UL/U_{out} = 2$.
 UL = charging voltage
 U_{out} = output voltage into 50 Ohm

13.1.2 Definition of the ESD Waveform

IEC 61000-4-2 Ed.2

Level	Test voltage kV+/-5%	Peak current A+/-15%	Amplitude at 30ns A+/-30%	Amplitude at 60 ns A+/-30%	Current peak
1	2	7,5	4	2	
2	4	15	8	4	
3	6	22,5	12	6	
4	8	30	16	8	

It is only possible to check the impulse current by using very expensive measuring equipment. The price of such an instrument today lies at approx. 50 k\$. In addition, persons who carry out such tests must have some experience with high voltage and high frequency test work, so that they can interpret the measured values. The calibration and verification of the generators must be carried out by the manufacturer or the official calibration authorities.

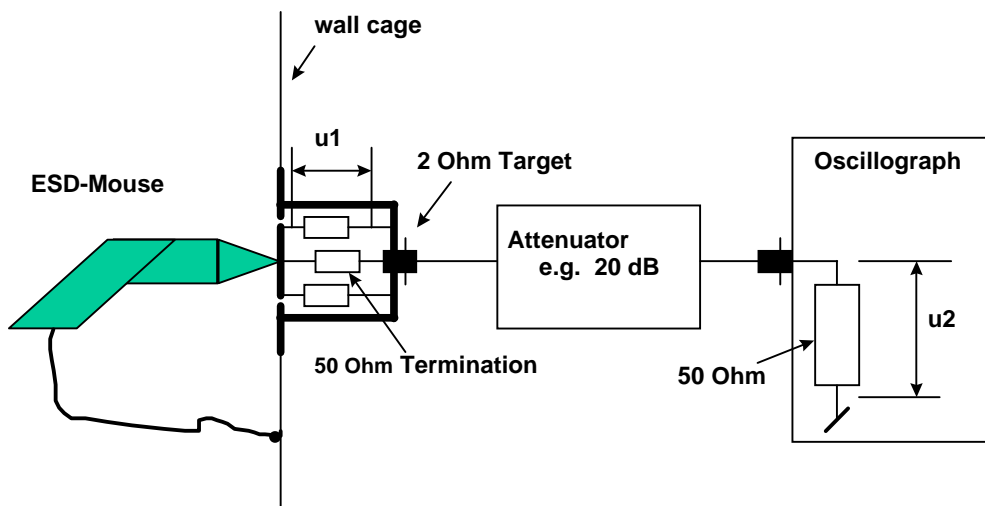

IEC 61000-4-2 Ed.1

The ESD-current produces on 2 Ohm Shunt a voltage drop u_1 . The 2 Ohm target is terminated with 50 Ohm to avoid reflection. With the 20 dB attenuator the 60V drop on the 2 Ohm will be reduced to the allowed input voltage of the oscilloscope. The memory oscilloscope must have a minimum bandwidth of 1 GHz. For all four levels (2,4,6,8 kV) the current wave-form must be within the tolerances as specified in the IEC standard 61000-4-2.

IEC 61000-4-2 Ed.2

The ESD-current produces on 2 Ohm Shunt a voltage drop u_1 . The 2 Ohm target is no longer terminated with 50 Ohm. To avoid reflection the attenuator must be inserted on the target side. With the 20 dB attenuator the 60V drop on the 2 Ohm will be reduced to the allowed input voltage of the oscilloscope. The memory oscilloscope must have a minimum bandwidth of 2.5 GHz. For all four levels (2,4,6,8 kV) the current wave-form must be within the tolerances as specified in the IEC standard 61000-4-2 Ed.2.

13.1.3 Definition of the SURGE Waveform

CWG Combination Wave Generator

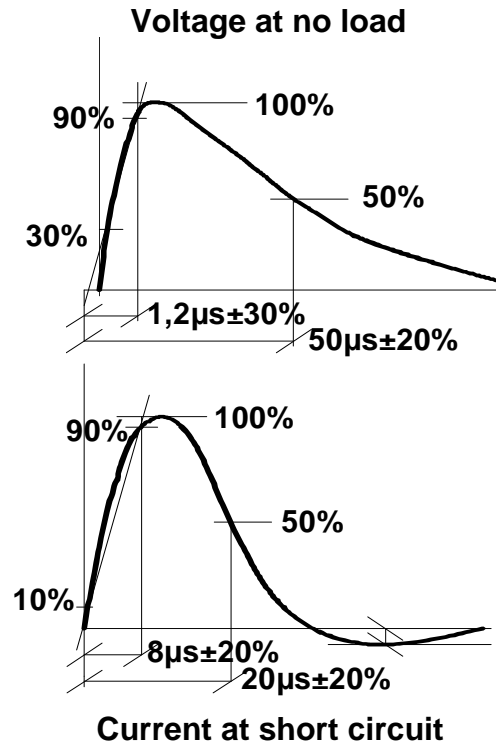
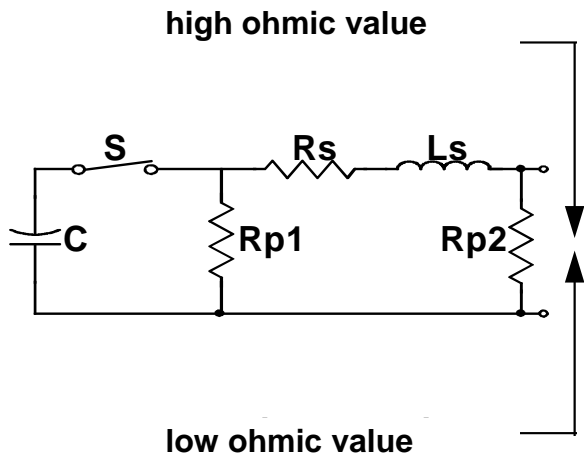

With this information the SURGE circuit of the TRA3000 E-F-S-D-V-C can be easily verified.

Example: "Voltage"

- choose 1 kV charging voltage
- measure the no load voltage at the generator output. Check whether the wave-form is within the tolerances or not.

Surge voltage front time $T_1=1.2 \mu s \pm 30\%$	0.84 - 1.56 μs
Time to half value $T_2= 50 \mu s \pm 20\%$	40 - 60 μs
measure U_{max} .	

Example "Current"

- choose 1 kV charging voltage
- measure the short circuit current at the generator output. Check whether the waveform is within the tolerances or not.

Surge current front time $T_1= 8 \mu s \pm 20\%$	6.4 - 9.6 μs
Time to half value $T_2=20 \mu s \pm 20\%$	16 - 22 μs
measure I_{max}	

Check the source impedance:

$$U_{max} / I_{max} = 2 \text{ Ohm} \pm 10\%$$

13.1.4 DIPS Specification

Test levels DIPS

Test Level % U_T	Voltage Dip/int % U_T	Duration (in period)
0	100	0.5*
40	60	5 10 25 50
70	30	x

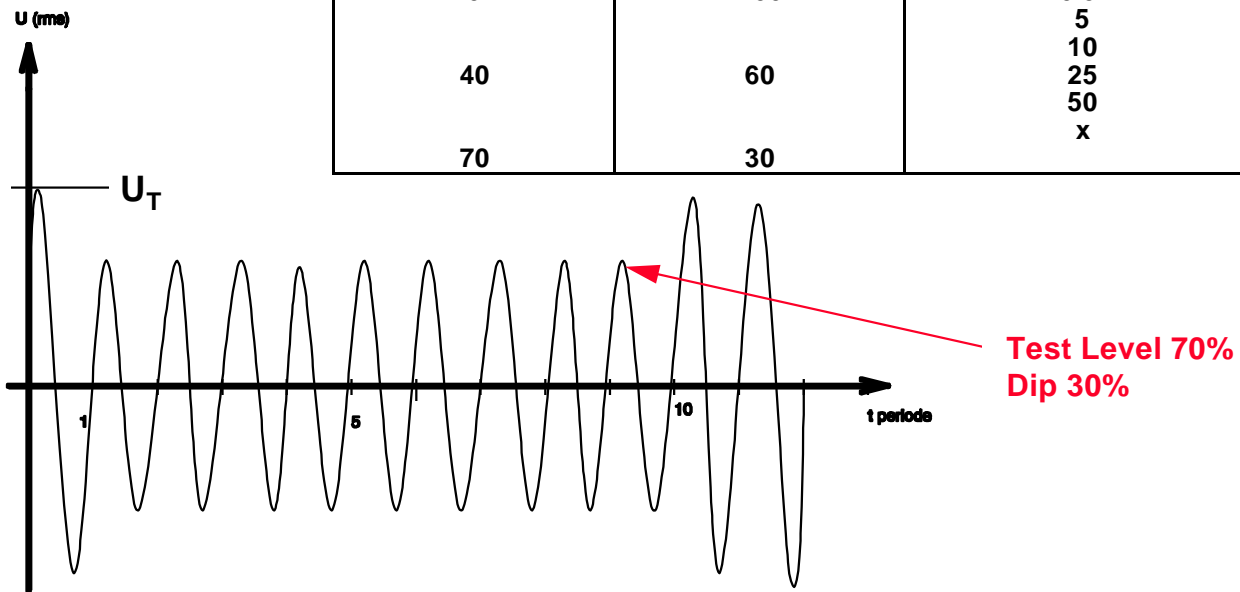

In addition to the data showed in the figure, such as test levels, duration of the interruption, transition time, etc., the inrush current must be tested. Electronic equipment very often contain inrush current limitation circuits. These inrush limiting circuits are often bypassed during interrupts at the turn on part. Consequences are defective power switching modules, or the equipment can not be turned on after the test because the software has not made a restart etc.

So that the test will cover this aspect, the inrush current capability of the generator must be at least 500 A peak. The verification of the generator inrush current is defined as follow:

Turn on the generator at a phase angle of 90 degrees. Using a current sensor, measure the current in a capacitor of several μF . The measured amplitude must be equal to/or greater than 500 A. When the tester can generate a current amplitude of 500 A, all equipment with current consuming up to 16 A can then be tested.

If the current amplitude of 500 A is not reached, then the inrush current of the EUT must be measured. The inrush current of the tester must be a minimum of 30 % higher than the inrush current of the EUT.

13.1.5 VARIATION Specification IEC 61000-4-11 Ed.1

Test levels Voltage variation

Voltage Test Level	Time for decreasing Voltage	Time at reduced voltage	Time for increasing voltage
40 % U_T	2 s \pm 20 %	1 s \pm 20 %	2 s \pm 20 %
0 % U_T	2 s \pm 20 %	1 s \pm 20 %	2 s \pm 20 %
	'x' 1)	'x' 1)	'x' 1)

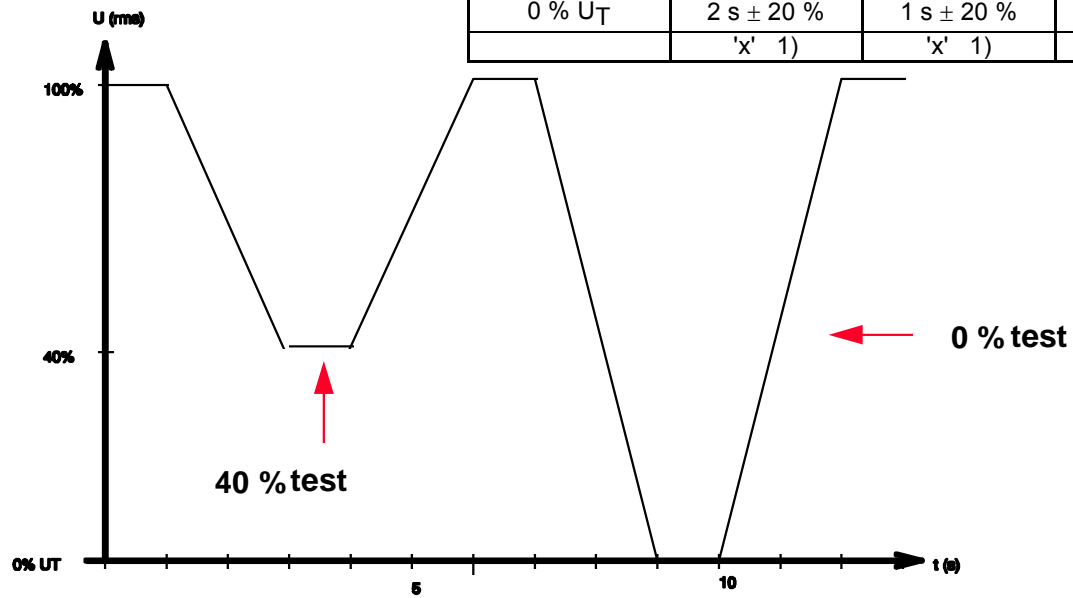

13.1.6 VARIATION Specification IEC 61000-4-11 Ed.2

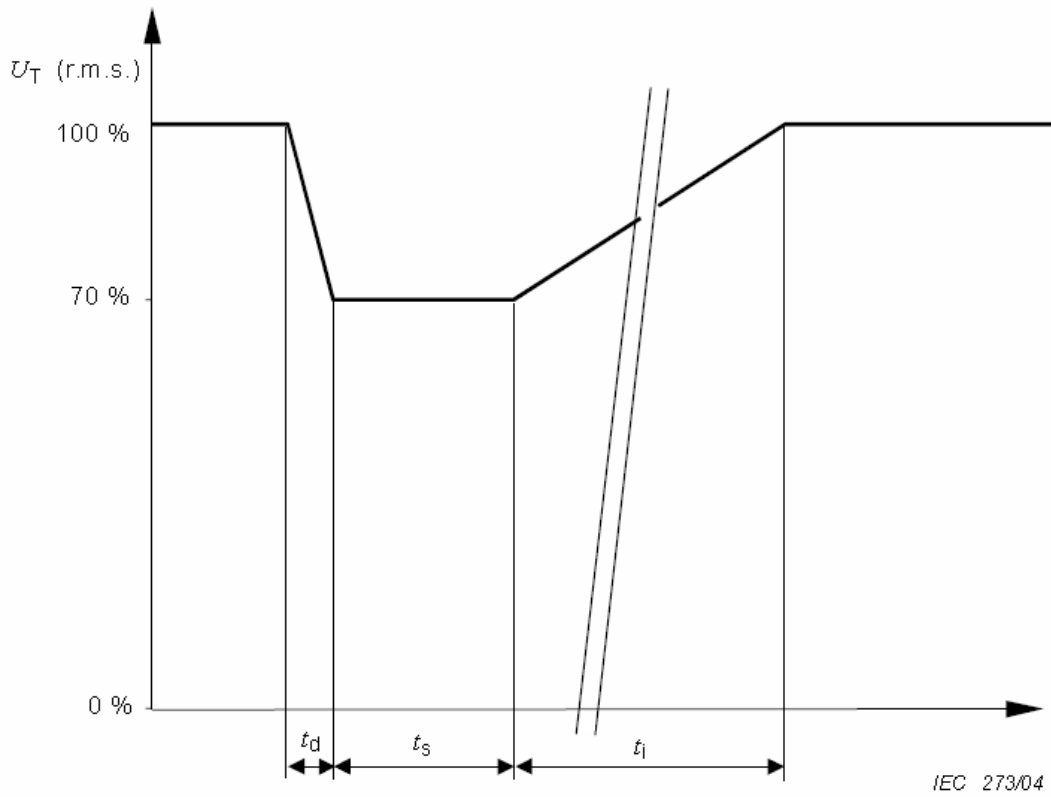

Key

- t_d Time for decreasing voltage
- t_i Time for increasing voltage
- t_s Time at reduced voltage

Voltage test level	Time for decreasing voltage (t_d)	Time at reduced voltage (t_s)	Time for increasing voltage (t_i) (50 Hz/60 Hz)
70 %	Abrupt	1 cycle	25/30 ^b cycles
X ^a	X ^a	X ^a	X ^a

^a To be defined by product committee.

^b "25/30 cycles" means "25 cycles for 50 Hz test" and "30 cycles for 60 Hz test".

13.2 Correction

13.2.1 Declaration of conformity to the EMC directive 89/336/EEC

see appendix at the end of this documents.

13.2.2 Declaration of conformity to the LV directive 93/68/EEC

see appendix at the end of this documents.

13.2.3 Declaration of conformity to the Basic Standards





see appendix at the end of this documents.

14 Glossary

Wherever possible, definitions in accordance with IEC 50 (IEV 161) are used.

EUT	Equipment under Test
EST	French abbreviation of EUT
EMV = EMC = CEM	Electro Magnetic Compatibility German: Elektromagnetische Verträglichkeit French: compatibilité elctromagnétique
Hybrid pulse	Voltage at no load 1.2 / 50 μ s and current at short circuit 8 / 20 μ s.
CWG	Definition in IEC 1000-4-5 used for Surge Tester Combination wave generator.
Coupling network	Electric circuit for transferring energy with low losses from one circuit into another circuit.
Decoupling network	Electric circuit to prevent transmitting energy from one circuit into another circuit.
CDN coupling decoupling network (single or three phase unit)	Consist of a coupling and a de-coupling network.
EFT	Electric Fast Transient (switched inductance)
ESD	Electric Static Discharge
SURGE	Transients with high energy content with relatively low frequency content as produced by lightning and switching of power lines.
DIP	Short voltage interruption or short voltage drop
IEC	International standardisation organisation for electronic technology
VARIAC	Voltage variable transformer
SPIKE	One pulse of the burst
CRO	oscilloscope
HV	High Voltage
rms.	root mean square; effective value

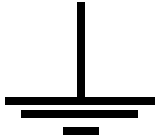
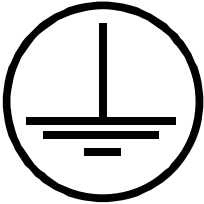
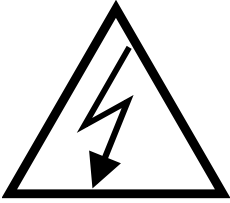
Used symbols:

	<p>Direct current</p>
	<p>Alternating current</p>
	<p>Three phase alternating current</p>
	<p>Earth (ground) terminal</p>
	<p>Protective conductor terminal IEC 417, No. 5019</p>
	<p>Caution, risk of electric shock ISO 3864, No. B.3.6</p>
	<p>Caution (refer to accompanying documents) ISO 3864, No. B.3.1</p>
	<p></p>

15 Index

A

Air discharge	70
Attention refer to manual	32, 34, 36, 45, 49
Attention refer to manual (45)	47

B

Bad parameter for this extension	101
Basis fault	101
Burst duration Ramp	79

C

Calibration at EMC PARTNER	97
Capacitor voltage to low	101
CDN16-450C	109
CDN2000-06-32	109
CDN2000A-06-32	109
CDN2000A-06-32 480V	109
CDN2000A-06-32 CMC	109
CDN2000A-06-63	110
CDN-A-3P100-480 F	110
CDN-A-3P100-480 F-S	110
CDN-A-3P100-690 F	110
CDN-KIT1000	111
CE mark	46
Check before operation	49
Climatic Condition	31
CN16	111
CN16T	111
CN2000-22-5	111
CN2000TT MC	111
CN-BALUN	111
CN-EFT1000	111
Command BOF	119
Command BTR	119
Command DEF	118
Command E	123
Command EUT	119
Command FID	122
Command GTL	123
Command ID	122
Command IMAX	119
Command IMIN	119
Command IPK	122
Command IT	120
Command LC	122
Command LN	121
Command LS	121
Command LV	121
Command NBR	117
Command PAU	120
Command POL	117
Command PON	118
Command REN	123
Command REP	117
Command ST	121
Command STOP	120

Command STRT	120
Command SYA	118
Command SYF	118
Command TRIG	118
Command TST	117
Command VMAX	119
Command VMIN	119
Command VNOM	117
Command VPK	122
Commands Format	115
Common Mode Disturbance source	12
Common Mode Test Technical data	25
Communication error	101
Contact Discharge	70
Control Indication and LED colours Technical Data	41 28
control keys Operation panel	44
Control panel Control part	41
Control Panel Front of the TRA3000 E-F-S-D-V-C	41
Coupling network	143
Coupling path	68
Coupling-Decoupling Network CWG	39 143

D

dc power on EUT	52
Decoupling network	143
delivered standard set-ups	59
DIP End	75
DIP Level Ramp	82
DIPS Begin Ramp Definition End Ramp Hints to test set-up Ramps Short Dip Run Mode Run Mode "Long Dip" source Technical data	83 74 83 56 82 89 89 11 23
DIPS fault	101
DIPS100E	111
Display (1)	42
Display messages	99
DN2000-22-5 down (15)	110 43

E

Earth connection (34)	45
Editing EFT test set-ups	67, 70, 71, 74
Editing of SURGE parameters	71
Editing short DIPS	74
EFT characteristics	11

Coupling path	68
coupling-decoupling network CDN	21
Hints to the test set-up	53
Quick verification by the user	95
Ramps	78
source	9
Synchro angle ramp	79
Technical data	21
EFT fault	101
EFT INSULATION	111
EFT Run Mode	86
Electromagnetic Compatibility	32
EMC	143
Emergency Stop	45, 48, 86
ENTER (14)	43
Error caused by incorrect inputs	99
Error on PWR1	101
Error on PWR2	101
ESD	
Air Discharge	70, 87
Contact Discharge	70, 87
Editing ESD test set-up	70
Ramps	79
Run Mode	87
source	9
Technical data	20
ESD characteristics	11
ESD fault	101
Ethernet	
Remote control	48
Ethernet port	113
EUT	143
EUT failed control	84
Failed input	48
EUT Power 1 Inputs	47
EUT Power 2	47
EUT Power measuring outputs	43
External Event	100
External Variac	51
EXT-TRA3000 C	109
EXT-TRA3000 C-SHORT	109
EXT-TRA3000 D	109
EXT-TRA3000 D-V-29D	109
EXT-TRA3000 D-V-29I	109
EXT-TRA3000 E	109
EXT-TRA3000 F	109
EXT-TRA3000 S	109
EXT-TRA3000 V	109

F

Forced cooling	48
----------------	----

H

Hardware power status fault	99
High voltage (29) and control plugs ESD (28)	45
High voltage pulse output EFT	45
High Z	77
High Z Mode	39
HV charge timeout	101
HV-Overshoot	101
HV-Regulation Fault	101

I

Important	
System Reset	104
Impulse output SURGE (30,31)	45
Impulsforming Network	38
Indication of voltage variation (25)	45
Input power N> 50V and L-N <N	99
Inquiry command	116
Interface	
PC	47
Printer	47
Internal Variac	51
Internal Variac connection	50

L

Leakage current	50
Local or remote control	114

M

Maintenance	95
Manual Trigger (20)	44
Measuring Circuit	38
Measuring circuits	
Technical Data (BNC-Connectors)	27
Mechanical dimension	28
Mechanical structure	
19" Insert version	37
Standard	37
With military box	37
Menu	
Ramp	78
MF1000-1	112
MF1000-2	112
MF1000-3	112
MF1STAND	112
MF3STAND	112

N

Neutral > 50 V	100
No Firing	101
No High Voltage	101
No Path Defined	99
No power input	99
No synchronisation signal	101
Numeric control panel (18)	43
NW-TRA-RAIL	111

O

Operational Conditions	31
------------------------	----

P

Packaging and shipment	105
Page up und Page down (7,8)	42
Pause	86

personal safety	31
PFS32	110
PFS63	110
PFS75	110
Power EUT (24)	45
Power line voltage, power consumption	28
Power must be 0	99
Power supply of the TRA3000 E-F-S-D-V-C	46
Push button ON/STBY (6)	42
Push buttons F1 to F4 (17)	43
Putting out of operation	104

Q

Quickstart	59
------------	----

R

Random Mode	69
Recycling/Disposal	107
Remote	115
Remote Control Commands	124
Remote-Control Commands	115
repetition < 100 ms	99
Repetition < 100 ms	99
RS 232C port	114
Run (19)	44
Run Mode	86

S

Safety	
Precautionary measure	32
Safety	
Standards	31
self Firing	101
Seminars	49
Separation signs:	115
Service, Repair	102
Signalling the EMC test type (20)	44
Single phase power output	44
Spike Frequency Ramp	79
Spike Rate	67
Spike Rate Limits	68
SRC32-18UH	110
SRC32-36UH	110
SRC63	110
SRC75	110
Standby Mode	86

SURGE	143
Coupling network	22
error message	85
hints to test set up	55
Ramps	81
Repetition	71
Run Mode	88
source	10
Synchronisation	73
Technical Data	22
SURGE fault	101
SURGE Measuring outputs	43
Symbols	144
Synchro	69
Synchro ON EUT Power (26)	45
Synchronisation on Output	73
Synchronisation on Power	72
Syncro	69

T

TEMA	112
TEMA DSO CONTROL	112
Test	143
test set-up for table top equipment	57
Timeout	100
TRA-Setup	111
Trigger output for oscilloscope (13)	43
Triggering	
External Measuring equipment	27

V

VAR-EXT1000	110
Variac Control	47
variac Fault	99, 101
VARIATION	
Editing the test set-up Variation	77
Ramps at variation	84
Run Mode	89
Technical Data	24
VERI1K EFT	111
VERI50 EFT	111
VERI-DIPS	111
Versions TRA3000 E-F-S-D-V-C	13

W

Warnings	46
----------	----

Declaration of Conformity to Standards

The EMC Tester

Type: TRA3000 E-F-S-D-V-C

complies with the following standards:

EFT
ESD
SURGE
a.c. MF
Surge MF
DIPS and INTERRUPTION on a.c. power
COMMON MODE

INTERRUPTION on d.c.

IEC/EN 61000-4-4 Ed.2
IEC/EN 61000-4-2 Ed.2
IEC/EN 61000-4-5 Ed.2
IEC/EN 61000-4-8 Ed.2 with antenna
IEC/EN 61000-4-5 Ed.1 with antenna
IEC/EN 61000-4-11 Ed.2 single phase
IEC/EN 61000-4-16 Ed.1 Amd2 with
accessories.
IEC/EN 61000-4-29 Ed.1



Laufen, 02. February 2010

EMC PARTNER AG



M. Lutz
Managing Director

EMC PARTNER AG



R. Henz
Manager Quality

Appendix to 14.2.3 Conformity declaration with basic standards



Manufacturer Declaration Of Conformity LV

Directive 73/23/EWG; with table VI 2006/95/EG

The EMC Tester

Type: TRA3000 E-F-S-D-V-C

is designed and manufactured complying with the following harmonised standards:

Harmonised:
EN 61010-1: 2001

international
IEC 61010-1

in accordance with the regulation of LV - directive of the members states 73/23/EWG and with table VI 2006/95/EG

EMC PARTNER authorised representative established within the EC Community

H+H High Voltage
Technology GmbH
Im kurzen Busch 15
DE - 58640 Iserlohn

Laufen, 05.August 2009

EMC PARTNER AG



M. Lutz
Managing Director

EMC PARTNER AG



R. Henz
Manager Quality Department

Appendix to 14.2.2 Conformity declaration with Low Voltage Directive 93/68/EEC and with table VI 2006/95/EG



Manufacturer Declaration Of Conformity EMC

Directive 89/336/EEG with table VII 2004/108/EG

The EMC Tester

Type: TRA3000 E-F-S-D-V-C

has been tested in accordance with the following standards:

harmonised:
EN 61000-6-3: 2007
EN 61326: 2006

international
IEC 61000-6-3
IEC 61326-1

Fulfilling the directions of the EMC - Directive 89/336/EEG and with table VII 2004/108/EG

EMC PARTNER authorised representative established within the EC Community

H+H High Voltage
Technology GmbH
Im kurzen Busch 15
DE - 58640 Iserlohn

Laufen: 02.Februar 2010

EMC PARTNER AG



M. Lutz
Managing Director

EMC PARTNER AG



R. Henz
Manager Quality Department

Appendix to 14.2.2 K Conformity declaration with the EMC directive

