



# RADIATING LOOP ANTENNA & SENSOR SET LAS 6120

USER MANUAL



# **RADIATING LOOP ANTENNA & SENSOR SET LAS 6120**

**USER MANUAL**

# CONTENT

<b>1.</b>	<b>Safety advice</b> .....	<b>5</b>
1.1.	Safety and warning symbols .....	5
1.2.	Safety Aspects .....	6
1.3.	Connection to the mains and PE .....	6
1.4.	Connections to other ports with dangerous voltages (AE, EUT, RF port ...)	6
1.5.	Connection to the ground plane or Faraday cage .....	6
1.6.	Disconnection from the mains, PE, ground and control devices.....	7
1.7.	Use proper fuses .....	7
1.8.	Risk of electric shock.....	7
1.9.	Operating Environment .....	7
1.10.	Test execution .....	8
1.11.	Dangers concerning the generator.....	8
1.12.	Dangers concerning the EUT .....	8
1.13.	Applicable safety standards.....	8
1.14.	Intended use .....	9
1.15.	Warranty Terms .....	9
1.16.	Prohibition of unauthorized conversions and modifications.....	9
1.17.	Specific accessories required for safety reason .....	9
1.18.	Procedure in case of hazard .....	9
<b>2.</b>	<b>Unpacking, storage and transport</b> .....	<b>10</b>
2.1.	General .....	10
2.2.	Storage and transport .....	10
2.3.	Unpacking .....	10
2.4.	Scope of delivery .....	10
<b>3.</b>	<b>Application and standard requirements</b> .....	<b>12</b>
3.1.	Test level setting.....	12
3.2.	Testing.....	14
3.3.	Influence of the distance on the magnetic field strength .....	15
3.4.	Expected correlations for selected test levels .....	16
<b>4.</b>	<b>Construction of the product</b> .....	<b>19</b>
<b>5.</b>	<b>Correction factor and Conversion</b> .....	<b>20</b>
5.1.	Magnetic field .....	20
5.2.	Current .....	23
<b>6.</b>	<b>Technical specification</b> .....	<b>25</b>
<b>7.</b>	<b>Maintenance</b> .....	<b>28</b>
7.1.	General.....	28
7.2.	Cleaning .....	28
<b>8.</b>	<b>Disposal</b> .....	<b>28</b>

## PICTURES

Figure 1: Set up example for test level setting .....	12
Figure 2: Example for test level setting.....	13
Figure 3: Set up example for testing .....	14
Figure 4: Example for typical power requirements using NSG 4070-LFCP .....	18
Figure 5: Construction of the product.....	19
Figure 6: FSL 6040-51 Field Sensor Loop typical correction factor .....	25

## TABLES

Table 1: Calculated field strength deviation in relation to the distance .....	15
Table 2: Expected correlations for test level 1 A/m.....	16
Table 3: Expected correlations for test level 3 A/m.....	16
Table 4: Expected correlations for test level 10 A/m.....	17
Table 5: Expected correlations for test level 30 A/m.....	17
Table 6: Expected correlations for test level 8 A/m at 30 kHz and 65 A/m at 134.2 kHz .....	18
Table 7: Conversion example for the receiving antenna.....	21
Table 8: Conversion example for the transmitting antenna.....	22
Table 9: Conversion example in 50 $\Omega$ system.....	24
Table 10: FSL 6040-51 Field Sensor Loop typical correction factor .....	26







# 1. SAFETY ADVICE



Observe all precautions to assure your personal safety. Read the user manual carefully. Pay special attention to safety and operation details!

## 1.1. Safety and warning symbols

Please take note of the following explanations of the symbols used in order to achieve the optimum benefit from this manual and to ensure safety during operation of the equipment.

	This symbol warns of a potential risk of shock hazard. Use standard safety precautions to avoid personal contact with these voltages.
	This symbol indicates where a caution is required. Refer to the operating instructions located in the manual in order to protect against personal injury or damage the equipment. It calls attention to a procedure, practice or condition which, if not followed, could possibly cause damage to equipment. Such damage may invalidate the warranty. Do not proceed until its conditions are fully understood and met.
	This symbol indicates non-ionizing radiation. Non-ionizing radiation may pose a health hazard to operators. Protective measures such as switching off the RF before entering the Faraday cage, level limitation and/or spatial distance are common measures.
	This symbol indicates access of persons with pacemakers prohibited.
	This symbol indicates the ground terminal.
	This symbol indicates the protective earth terminal.

## 1.2. Safety Aspects

These operating instructions form an integral part of the equipment and must be available to the operating personnel at all times. The user must obey all safety instructions and warnings.

Neither AMETEK CTS Europe GmbH nor any of its subsidiary sales organizations can accept any responsibility for personal, material or consequential injury, loss or damage that results from improper use of the equipment and accessories.



WARNING

Improper or careless handling can be fatal!  
Use of the generator is restricted to authorized and trained specialists

## 1.3. Connection to the mains and PE

- ▶ Before switching on the device, check whether the selected voltage matches the supply voltage. The position of the voltage selector must correspond with the mains. If you change the mains voltage, replace the fuses according to the recommended value.
- ▶ A proper protective earth connection through the connector of the power cord is essential for safe operation.
- ▶ High leakage currents can cause the residual current circuit breaker of the mains to trip. In this case, the use of an isolating transformer is required.
- ▶ Handle the power cord carefully. Hold the plug when unplugging the cord.
- ▶ Never use the product if the power cord or the plug is damaged.
- ▶ Use only power cords and connector specified for your product.
- ▶ Do not abuse the cord. Never use the cord for carrying, pulling or unplugging the unit. Keep cord away from heat, oil, sharp edges or moving parts.
- ▶ Prevent the device from being switched on or energized unintentionally. Make sure that the switch is in the off position before connecting the device to the mains.
- ▶ Disconnect the power plug if you are not going to use the device for a long period of time.

## 1.4. Connections to other ports with dangerous voltages (AE, EUT, RF port ...)

- ▶ Only use the connection cables and plugs specified for your product which enable safe working. They must comply with the required classification and have suitable voltage and current ratings for the application.
- ▶ Handle the connection cable carefully. Hold the plug when unplugging the cable.
- ▶ Never use the product if the connection cable or plug is damaged.
- ▶ Avoid touching conductive parts unless they have been de-energized by suitable means and secured against being switched on again for the period of handling. Industrial connectors often have insufficient protection against electric shock due to their application.

## 1.5. Connection to the ground plane or Faraday cage

- ▶ Remove the protective foil from under the device and adapter housing to ensure good electrical contact.
- ▶ Light equipment should be weighted down, clamped to the base plate or other measures should be taken to ensure good electrical contact over a wide surface area and on a permanent basis.



- ▶ Connect the device with the ground plane before using.
- ▶ The operation without a second, only with a tool removable earth leakage connection is prohibited.
- ▶ Check the ground connection at regular intervals.

- ▶ Ensure that a reliable return path for the interference current is provided between the equipment under test (EUT) and the generator. The reference ground plane and the earth connections to the instrument as described in the relevant test standard serve this purpose well.

#### 1.6. Disconnection from the mains, PE, ground and control devices

- ▶ Always set the power switch to the "Off" position and wait few seconds before disconnecting the power cord.
- ▶ Disconnect the power cord and all connection cords when moving the unit.

#### 1.7. Use proper fuses

- ▶ To avoid fire hazard, use only fuses as specified in the parts listing for your product - matching type, voltage and current rating.

#### 1.8. Risk of electric shock



WARNING

- ▶ To reduce the risk of electric shock, do not remove parts from the housing.
- ▶ There are no user serviceable parts inside the unit. Certain parts inside the instrument work at mains voltage or at high frequency and are not provided with any protection against being touched.
- ▶ Only approved accessory items, connectors, adapters, etc. are to be used to ensure safe operation.



WARNING

- ▶ Not all lines, especially EUT supply lines, inside the device are protected by a fuse. Therefore, the user must implement the protection of the device against short-circuits by means of suitable fuses / circuit breakers.
- ▶ Avoid an overload by taking suitable precautions.
- ▶ In the event of a fault, dangerous and unexpected voltages may occur. Avoid touching conductive parts unless they have been de-energized by suitable means and secured against being switched on again for the period of handling.

#### 1.9. Operating Environment

- ▶ Operate the equipment only in dry surroundings. Allow any condensation that occurs to evaporate before putting the instrument into operation. Do not exceed the permissible ambient temperature, humidity or altitude above sea level. Operate the unit not in explosive surroundings.
- ▶ No objects filled with liquids, such as coffee cups, shall be placed on the unit.
- ▶ Do not insert foreign objects in the ventilation holes.
- ▶ Do not obstruct the ventilation holes (also on the underside). Ventilation should not be impeded by covering the ventilation openings with items or other equipment.
- ▶ Avoid high temperatures. Allow for sufficient heat dispersion when installed in a rack. Do not place the product on radiators or fan heaters. The ambient temperature must not exceed the maximum specified temperature of this product.
- ▶ Keep the test area clean and well lit. Cluttered or dark areas invite accidents.

### 1.10. Test execution

- ▶ Check once again that all connections are proper including the ground and protective earth.
- ▶ Remove any adjusting key or wrench before switching on or energizing the device.
- ▶ The test area must be organized that no unauthorized persons have access during execution of a test.
- ▶ Operating the product requires special training and intense concentration. Make certain that persons who use the products are physically, mentally and emotionally fit enough to operate the products; otherwise injuries or material damage may occur.
- ▶ EUTs together with all accessories and cables are to be regarded as being live during the execution of a test.
- ▶ The safety instructions concerning all the instruments and associated equipment involved in the test setup are to be observed.
- ▶ The configuration of the test setup is to be strictly in compliance with the methods described in the relevant standard to ensure that the test is executed in a compliant manner.
- ▶ Working with high voltages alone is dangerous and prohibited by law.
- ▶ The high voltages must be switched off when nobody is present.

### 1.11. Dangers concerning the generator

- ▶ Local regulations for the protection of radio services must be observed. The interference generated by the generator can cause both conducted and radiated interference.
- ▶ If the radiated energy exceeds the permissible level, a shielded chamber with filtering of the supply lines or similar must be used. Decisive for the measures are the used levels, the geometry of the setup, the frequency range and the distance to the neighbor.
- ▶ Depending on the level used, the effectiveness of the connected antenna, TEM cell or similar, fields can be generated using appropriate power amplifiers, from which the operating personnel must be protected by suitable measures.
- ▶ Localized burning, arcing or ignition of explosive gases.
- ▶ Disruption of unrelated electronic, telecommunications or navigational installations or heart pacemakers through intentional and unintentional radiation of RF energy.



**WARNING**

Persons fitted with a heart pacemaker must not operate the instrument nor approach the test setup while it is in operation.

### 1.12. Dangers concerning the EUT

- ▶ EUTs are frequently simply functional samples that have not previously been subjected to any safety tests. Therefore, in some cases, the EUT is quickly damaged through internal overloads caused by the control electronics being disrupted. The EUT may even begin to burn.
- ▶ As soon as the EUT shows signs of damage the test should be stopped and the equipment under test should be switched off.
- ▶ Possible erroneous behavior by the EUT for example, a robotic device may misbehave, or a temperature regulator may fail.
- ▶ Even when power is off, capacitors may retain an electrical charge.

### 1.13. Applicable safety standards

- ▶ Development and manufacture of the instrument complies with ISO 9001.
- ▶ The equipment conforms with the essential requirements of the Low Voltage Directive (LVD) 2014/35/EU based on DIN EN 61010-1.



#### 1.14. Intended use



The purpose of this instrument is the coupling of defined interferences signals for EMI immunity testing. Depending on the test stand layout, configuration, wiring, and the characteristics of the EUT itself, a significant amount of electromagnetic radiation may be generated that can affect people as well as other equipment and systems. Likewise, this device can be used to decouple interfering signals for emission measurements.



WARNING

The device is designed for operation in industrial as well as home environment. For the intended operation, electromagnetic fields are generated by the connection of coupling devices (antennas, clamps, CDN etc.) or by the injection on lines. The operator, persons in the vicinity and the environment must be protected by suitable measures, e.g. Faraday cage.

#### 1.15. Warranty Terms

AMETEK CTS provides this written warranty covering the product stated above, and if the buyer discovers and notifies AMETEK CTS in writing of any defect in material or workmanship within the applicable warranty period stated above, then AMETEK CTS may, at its option: repair or replace the product; or issue a credit note for the defective product; or provide the buyer with replacement parts for the product.

The buyer will, at its expense, return the defective product or parts thereof to AMETEK CTS in accordance with the return procedure specified below. AMETEK CTS will, at its expense, deliver the repaired or replaced product or parts to the buyer. Any warranty of AMETEK CTS will not apply if the buyer is in default under the purchase order agreement or where the product or any part thereof:

- is damaged by misuse, accident, negligence or failure to maintain the same as specified or required by AMETEK CTS;
- is damaged by modifications, alterations or attachments thereto which are not authorized by AMETEK CTS;
- is installed or operated contrary to the instructions of AMETEK CTS;
- is opened, modified or disassembled in any way without AMETEK CTS's consent; or
- is used in combination with items, articles or materials not authorized by AMETEK CTS.

The buyer may not assert any claim that the products are not in conformity with any warranty until the buyer has made all payments to AMETEK CTS provided for in the purchase order agreement.

#### 1.16. Prohibition of unauthorized conversions and modifications

The user is not entitled to the device to perform its own modifications and adaptations. Modifying parts on the generator by unauthorized persons will void the warranty of the device and the correct functioning cannot be guaranteed.

#### 1.17. Specific accessories required for safety reason

Only use accessories approved by AMETEK CTS for these generators and intended as accessories for these devices. Measuring instruments for the measurement of instrument parameters shall be designed for the maximum voltage and current from the generator. Otherwise safety cannot be guaranteed.

#### 1.18. Procedure in case of hazard

If a hazard could exist due to an unintended condition of the device, the following procedure is recommended: Disconnect the device- and EUT power supplies from the power supply and ensure that the device is always earthed via the supply lines or a different ground connection. Wait at least 15 minutes and ground all outputs via a 10 k $\Omega$ , 15 W resistor. Call an AMETEK service center.

## 2. UNPACKING, STORAGE AND TRANSPORT

### 2.1. General

Save all packing materials! They will be needed in order to safely package the equipment for calibration service or repair.

Packaging materials

- Carton: Cardboard
- Padding: CFC-free polystyrene foam
- Plastic bags: Polyethylene





▶ Avoid the risk of condensation!

If a large temperature difference has occurred, allow time for the temperature to stabilize. This may take several hours.

### 2.2. Storage and transport

- ▶ Do not stack, either packaged or unpacked.
- ▶ Do not stand on end; arrows on the packaging must always point upwards.
- ▶ Protect from dampness, heat, cold and rain.
- ▶ Do not throw.
- ▶ Do not sit or stand on the instrument and packaging.

### 2.3. Unpacking

- Is the packaging damaged? If YES  transportation company
- Are all the packages present and correct? If NO  transportation company
- Open the packaging, remove the accessories.
- Grip the instrument at the sides and lift it from the packaging.
- Are the instrument or accessories damaged? If YES  transportation company
- Are the contents of the package complete? If NO  Teseq sales office
- Keep the instruction manual with the instrument.
- Keep the packaging.

### 2.4. Scope of delivery

RLA 6120-20(radiating loop antenna),
Spacer,
Radiation area panel (100 mm x 100 mm plate),
TPF 6120 (tripod fixture),
FSL 6040-51 (field sensing loop antenna),
CSP 9160A (current sensor),
LE 273 (two wire cable, with 4 mm banana plugs, 3 m),
2x RF cable (BNC(m)-BNC(m) 1 m, RG58),
2x N-BNC adaptor,
Banana to BNC adaptor,
ISO 17025 traceable calibration certificate (scope of calibration FSL 6040-51 and CSP 9160A)
User manual



The cables 2x RF cable (BNC(m)-BNC(m) 1 m, RG58) are behind the foam insert in the lid of the transport case.

### 3. APPLICATION AND STANDARD REQUIREMENTS

The Loop Antenna Set LAS 6120 is designed to generate and verify magnetic fields in close proximity to test the immunity of electrical equipment exposed to RF fields as required by the IEC 61000-4-39, IEC 60601-1-2 and MIL-STD-461 RS101 standards.

The LAS 6120 antenna set consists of a radiating loop antenna RLA 6120-20, field sensor loop FSL 6040-51 and a current sensor CSP 9160A, and guarantees the required distance of 50 mm needed to comply with the standard requirements.

FSL 6040-51 loop sensor with a diameter of 40 mm, offers electrostatic shielding and is supplied with the correction factor.

CSP 9160A is a clamp on probe used for verification of r.m.s current measurement as defined in the standard.

#### 3.1. Test level setting

For the operation of the Loop Antenna Set LAS 6120, the correct test level must be performed in the setup shown below before the actual test.

1. Connect the amplifier output via the N to BNC adapter and BNC to banana adapter with the banana cable to the transmitting antenna.
2. Feed one conductor of the banana cable through the current clamp (Do not lead both conductors through the current clamp!). Connect the current clamp via the BNC cable with the power meter. The current clamp must be connected to power meter channel 2 when using the NSG 4070.
3. Move the receive antenna to the 5 cm distance from the transmit antenna using the spacer.
4. Connect the receiving antenna with the BNC cable to the power meter. In case of NSG 4070 it is power meter channel 1.
5. Configure the test parameters in the software. Avoid damaging the power meters by calculating the expected levels beforehand. Use attenuators if necessary. Use the valid correction factors for current probe and receive antenna.
6. Perform the test level setting procedure save the result.

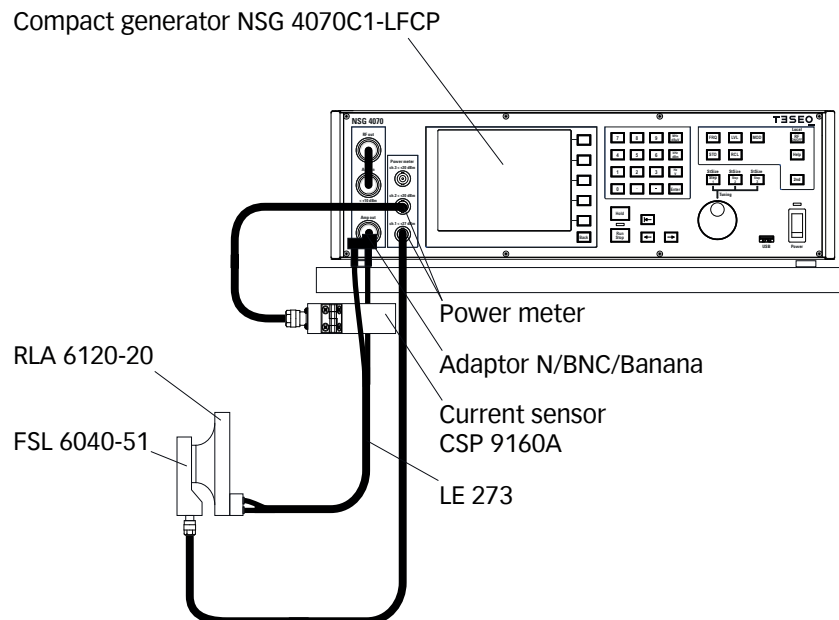

Figure 1: Set up example for test level setting

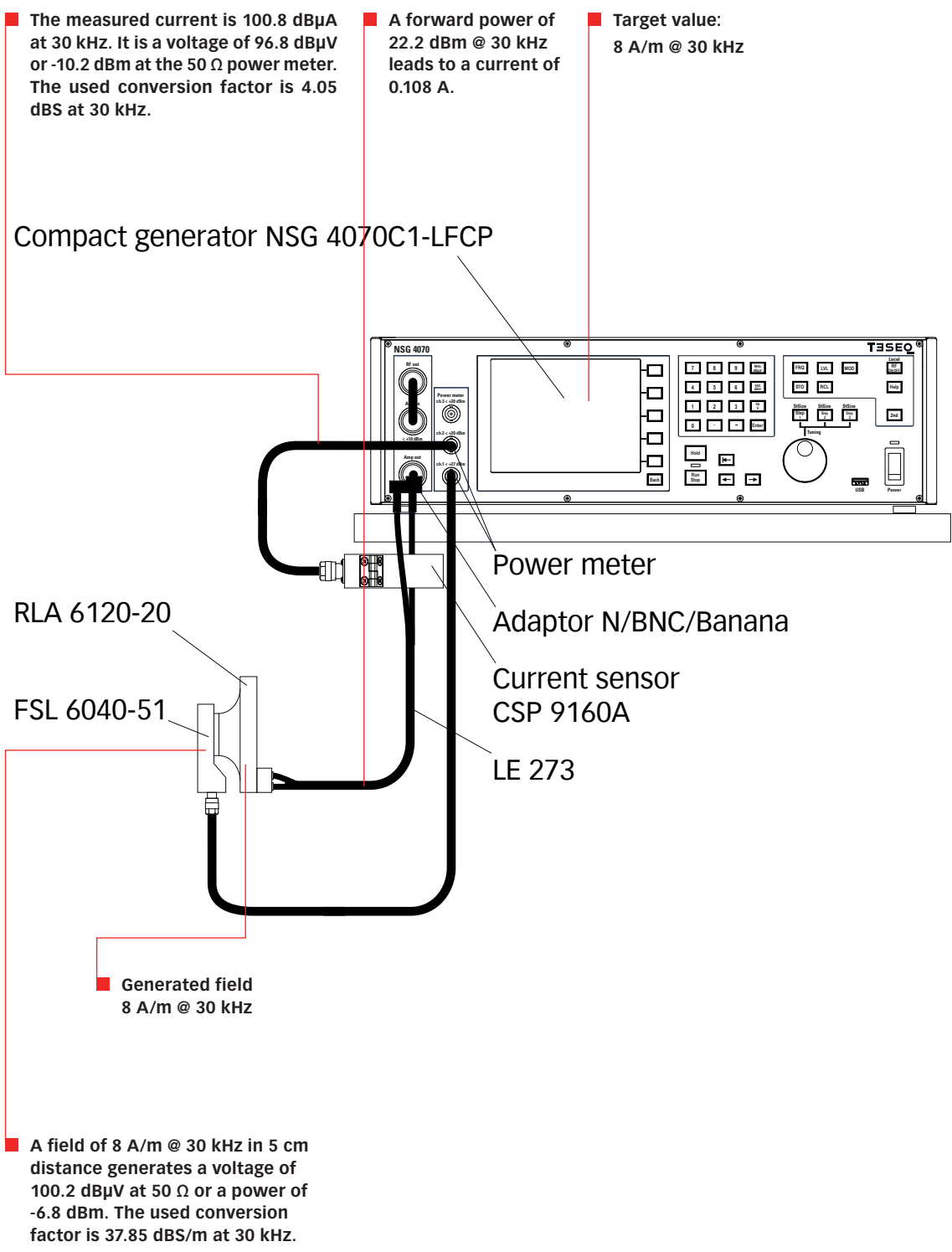
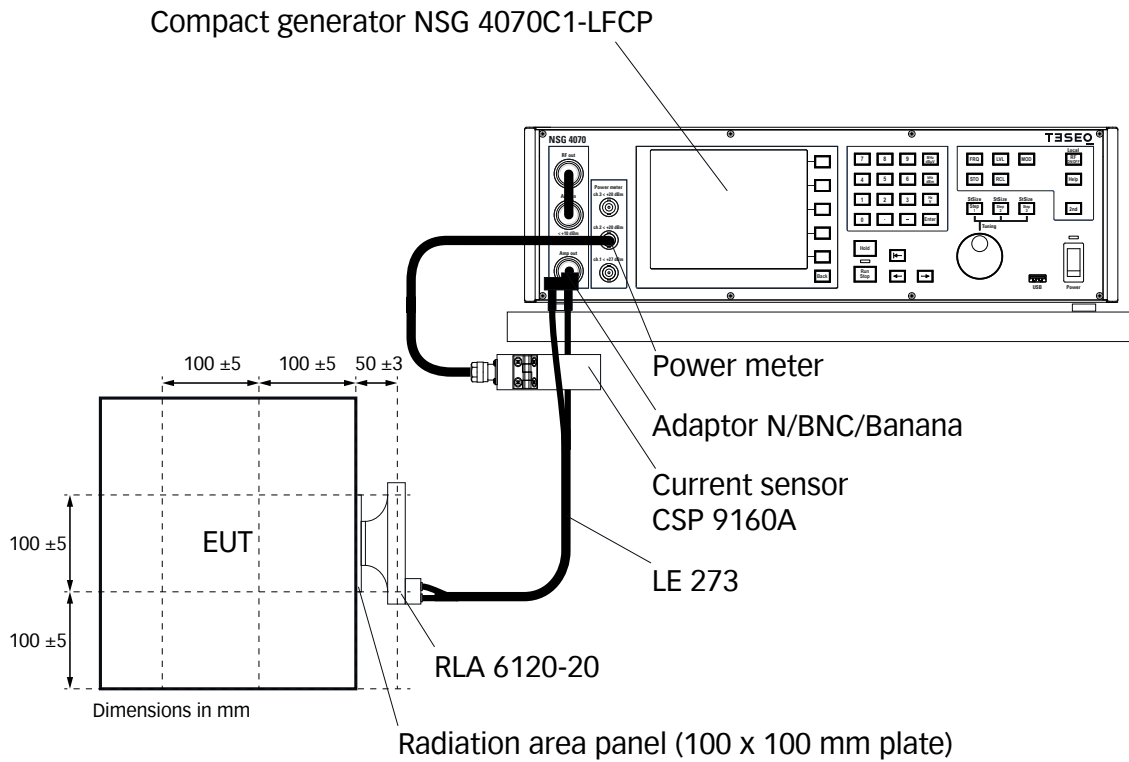

Figure 2: Example for test level setting

### 3.2. Testing

For the operation of the Loop Antenna Set LAS 6120, the test level setting procedure must have been performed beforehand.

1. Connect the amplifier output via the N to BNC adapter and BNC to banana adapter with the banana cable to the transmitting antenna.
2. Feed one conductor of the banana cable through the current clamp (Do not lead both conductors through the current clamp!). Connect the current clamp via the BNC cable with the power meter. The current clamp must be connected to power meter channel 2 when using the NSG 4070. To improve the accuracy, the forward power is not controlled as usual, but the current.
3. Remove the receiving antenna and place the radiation area panel at a distance of 5 cm from the transmitting antenna using the spacer.
4. Recall the test parameters and calibration result in the software. Avoid damaging the power meters by calculating the expected levels beforehand. Use attenuators if necessary. Use the valid correction factors for the current probe.
5. Perform the test.



**Figure 3: Set up example for testing**

### 3.3. Influence of the distance on the magnetic field strength

The following table shows the influence of the distance on the magnetic field strength. From this, conclusions can be drawn about the measurement uncertainty. Furthermore, the table helps to estimate the danger on the human body, e.g. when the antenna is held in the hand. For example, the Federal Office for Radiation Protection in Germany limits (26.BIMSCHV) a magnetic flux density of 27  $\mu\text{T}$  above 3 kHz. Based on the example shown below, the user's hand would have to be at least 10 cm away from the antenna.



**WARNING**

Avoid staying in the immediate vicinity of the antenna at field strengths above permissible values for the human body. For hand-held positioning, increase the distance to the antenna by suitable means (wooden stick). Note the dependencies in the table shown below.

Current in A	Distance in m	Field strength in A/m	Field strength in dB $\mu\text{A}/\text{m}$	Magnetic flux density in $\mu\text{T}$
1	0	166.67	164.44	208.33
1	0.01	159.96	164.08	199.94
1	0.02	142.30	163.06	177.88
1	0.03	119.26	161.53	149.07
1	0.04	96.01	159.65	120.01
1	0.05	75.56	157.57	94.45
1	0.06	58.93	155.41	73.66
1	0.07	45.94	153.24	57.42
1	0.08	36.00	151.13	45.00
1	0.09	28.45	149.08	35.56
1	0.1	22.70	147.12	28.37
1	0.11	18.30	145.25	22.88
1	0.12	14.91	143.47	18.63
1	0.13	12.27	141.77	15.33
1	0.14	10.19	140.16	12.73
1	0.15	8.54	138.63	10.67
1	0.16	7.21	137.16	9.02
1	0.17	6.14	135.77	7.68
1	0.18	5.27	134.44	6.59
1	0.19	4.55	133.16	5.69
1	0.2	3.95	131.94	4.94
1	0.21	3.46	130.77	4.32
1	0.22	3.04	129.65	3.79
1	0.23	2.68	128.56	3.35
1	0.24	2.38	127.52	2.97
1	0.25	2.12	126.52	2.65

**Table 1: Calculated field strength deviation in relation to the distance**

### 3.4. Expected correlations for selected test levels

Frequency in MHz	Field strength in A/m	Correction factor FSL 6040-51 in dBS/m	FSL 6040-51 on power meter in dB $\mu$ V	FSL 6040-51 on power meter in dBm	CSP 9160A on power meter in dBm	CSP 9160A on power meter in dB $\mu$ V	Correction factor CSP 9160A in dBS	Current in dB $\mu$ A	Current in A
0.009	1	47.4	72.6	-34.4	-36.6	70.4	12.5	82.9	0.01
0.01	1	46.5	73.5	-33.5	-35.7	71.3	11.6	82.9	0.01
0.02	1	40.9	79.1	-27.9	-30.7	76.3	6.5	82.8	0.01
0.03	1	37.8	82.2	-24.8	-28.3	78.7	4.1	82.8	0.01
0.04	1	36.0	84.0	-23.0	-27.1	79.9	2.7	82.7	0.01
0.05	1	34.7	85.3	-21.7	-26.4	80.6	2.0	82.6	0.01
0.06	1	33.9	86.1	-20.9	-26.0	81.0	1.5	82.5	0.01
0.07	1	33.2	86.8	-20.2	-25.8	81.2	1.2	82.5	0.01
0.08	1	32.8	87.2	-19.8	-25.6	81.4	1.0	82.4	0.01
0.09	1	32.4	87.6	-19.4	-25.5	81.5	0.9	82.4	0.01
0.1	1	32.2	87.8	-19.2	-25.3	81.7	0.8	82.4	0.01
0.11	1	32.0	88.0	-19.0	-25.3	81.7	0.7	82.3	0.01
0.12	1	31.8	88.2	-18.8	-25.3	81.7	0.6	82.4	0.01
0.13	1	31.7	88.3	-18.7	-25.3	81.7	0.6	82.3	0.01
0.14	1	31.6	88.4	-18.6	-25.2	81.8	0.5	82.3	0.01
0.15	1	31.5	88.5	-18.5	-25.2	81.8	0.5	82.2	0.01

**Table 2: Expected correlations for test level 1 A/m**

Frequency in MHz	Field strength in A/m	Correction factor FSL 6040-51 in dBS/m	FSL 6040-51 on power meter in dB $\mu$ V	FSL 6040-51 on power meter in dBm	CSP 9160A on power meter in dBm	CSP 9160A on power meter in dB $\mu$ V	Correction factor CSP 9160A in dBS	Current in dB $\mu$ A	Current in A
0.009	3	47.4	82.1	-24.9	-27.1	79.9	12.5	92.4	0.04
0.01	3	46.5	83.0	-24.0	-26.2	80.8	11.6	92.4	0.04
0.02	3	40.9	88.7	-18.3	-21.1	85.9	6.5	92.4	0.04
0.03	3	37.8	91.7	-15.3	-18.7	88.3	4.1	92.3	0.04
0.04	3	36.0	93.6	-13.4	-17.5	89.5	2.7	92.2	0.04
0.05	3	34.7	94.8	-12.2	-16.9	90.1	2.0	92.1	0.04
0.06	3	33.9	95.7	-11.3	-16.5	90.5	1.5	92.1	0.04
0.07	3	33.2	96.3	-10.7	-16.2	90.8	1.2	92.0	0.04
0.08	3	32.8	96.8	-10.2	-16.0	91.0	1.0	92.0	0.04
0.09	3	32.4	97.1	-9.9	-15.9	91.1	0.9	92.0	0.04
0.1	3	32.2	97.4	-9.6	-15.8	91.2	0.8	92.0	0.04
0.11	3	32.0	97.6	-9.4	-15.8	91.2	0.7	91.9	0.04
0.12	3	31.8	97.7	-9.3	-15.7	91.3	0.6	91.9	0.04
0.13	3	31.7	97.9	-9.1	-15.7	91.3	0.6	91.9	0.04
0.14	3	31.6	98.0	-9.0	-15.7	91.3	0.5	91.8	0.04
0.15	3	31.5	98.1	-8.9	-15.7	91.3	0.5	91.8	0.04

**Table 3: Expected correlations for test level 3 A/m**



Frequency in MHz	Field strength in A/m	Correction factor FSL 6040-51 in dBS/m	FSL 6040-51 on power meter in dB $\mu$ V	FSL 6040-51 on power meter in dBm	CSP 9160A on power meter in dBm	CSP 9160A on power meter in dB $\mu$ V	Correction factor CSP 9160A in dBS	Current in dB $\mu$ A	Current in A
0.009	10	47.4	92.6	-14.4	-16.6	90.4	12.5	102.9	0.14
0.01	10	46.5	93.5	-13.5	-15.7	91.3	11.6	102.9	0.14
0.02	10	40.9	99.1	-7.9	-10.7	96.3	6.5	102.8	0.14
0.03	10	37.8	102.2	-4.8	-8.3	98.7	4.1	102.8	0.14
0.04	10	36.0	104.0	-3.0	-7.1	99.9	2.7	102.7	0.14
0.05	10	34.7	105.3	-1.7	-6.4	100.6	2.0	102.6	0.13
0.06	10	33.9	106.1	-0.9	-6.0	101.0	1.5	102.5	0.13
0.07	10	33.2	106.8	-0.2	-5.8	101.2	1.2	102.5	0.13
0.08	10	32.8	107.2	0.2	-5.6	101.4	1.0	102.4	0.13
0.09	10	32.4	107.6	0.6	-5.5	101.5	0.9	102.4	0.13
0.1	10	32.2	107.8	0.8	-5.3	101.7	0.8	102.4	0.13
0.11	10	32.0	108.0	1.0	-5.3	101.7	0.7	102.3	0.13
0.12	10	31.8	108.2	1.2	-5.3	101.7	0.6	102.4	0.13
0.13	10	31.7	108.3	1.3	-5.3	101.7	0.6	102.3	0.13
0.14	10	31.6	108.4	1.4	-5.2	101.8	0.5	102.3	0.13
0.15	10	31.5	108.5	1.5	-5.2	101.8	0.5	102.2	0.13

**Table 4: Expected correlations for test level 10 A/m**

Frequency in MHz	Field strength in A/m	Correction factor FSL 6040-51 in dBS/m	FSL 6040-51 on power meter in dB $\mu$ V	FSL 6040-51 on power meter in dBm	CSP 9160A on power meter in dBm	CSP 9160A on power meter in dB $\mu$ V	Correction factor CSP 9160A in dBS	Current in dB $\mu$ A	Current in A
0.009	30	47.4	102.1	-4.9	-7.1	99.9	12.5	112.4	0.42
0.01	30	46.5	103.0	-4.0	-6.2	100.8	11.6	112.4	0.42
0.02	30	40.9	108.7	1.7	-1.1	105.9	6.5	112.4	0.41
0.03	30	37.8	111.7	4.7	1.3	108.3	4.1	112.3	0.41
0.04	30	36.0	113.6	6.6	2.5	109.5	2.7	112.2	0.41
0.05	30	34.7	114.8	7.8	3.1	110.1	2.0	112.1	0.40
0.06	30	33.9	115.7	8.7	3.5	110.5	1.5	112.1	0.40
0.07	30	33.2	116.3	9.3	3.8	110.8	1.2	112.0	0.40
0.08	30	32.8	116.8	9.8	4.0	111.0	1.0	112.0	0.40
0.09	30	32.4	117.1	10.1	4.1	111.1	0.9	112.0	0.40
0.1	30	32.2	117.4	10.4	4.2	111.2	0.8	112.0	0.40
0.11	30	32.0	117.6	10.6	4.2	111.2	0.7	111.9	0.39
0.12	30	31.8	117.7	10.7	4.3	111.3	0.6	111.9	0.39
0.13	30	31.7	117.9	10.9	4.3	111.3	0.6	111.9	0.39
0.14	30	31.6	118.0	11.0	4.3	111.3	0.5	111.8	0.39
0.15	30	31.5	118.1	11.1	4.3	111.3	0.5	111.8	0.39

**Table 5: Expected correlations for test level 30 A/m**

Fre- quency in MHz	Field strength in A/m	Cor- rection factor FSL 6040-51 in dBS/m	FSL 6040-51 on power meter in dBµV	FSL 6040-51 on power meter in dBm	CSP 9160A on power meter in dBm	CSP 9160A on power meter in dBµV	Cor- rection factor CSP 9160A in dBS	Current in dBµA	Current in A
0.03	8	37.8	100.2	-6.8	-10.2	96.8	4.1	100.8	0.11
0.1342	65	31.6	124.6	17.6	11.0	118.0	0.6	118.6	0.85

**Table 6: Expected correlations for test level 8 A/m at 30 kHz and 65 A/m at 134.2 kHz**

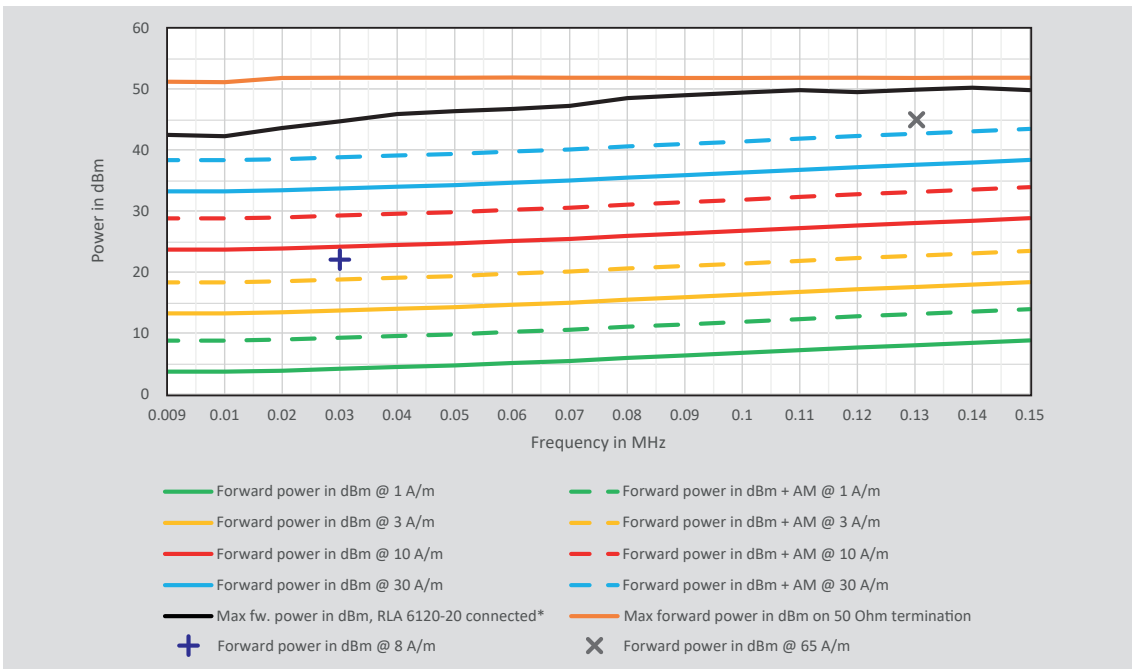

\* The display of the forward power via a 50 Ohm power meter at the directional coupler is distorted by the strong mismatch. It can therefore only be used to a limited extent. Likewise, the output power of an amplifier is dependent on the connected load.

**Figure 4: Example for typical power requirements using NSG 4070-LFCP**

## 4. CONSTRUCTION OF THE PRODUCT

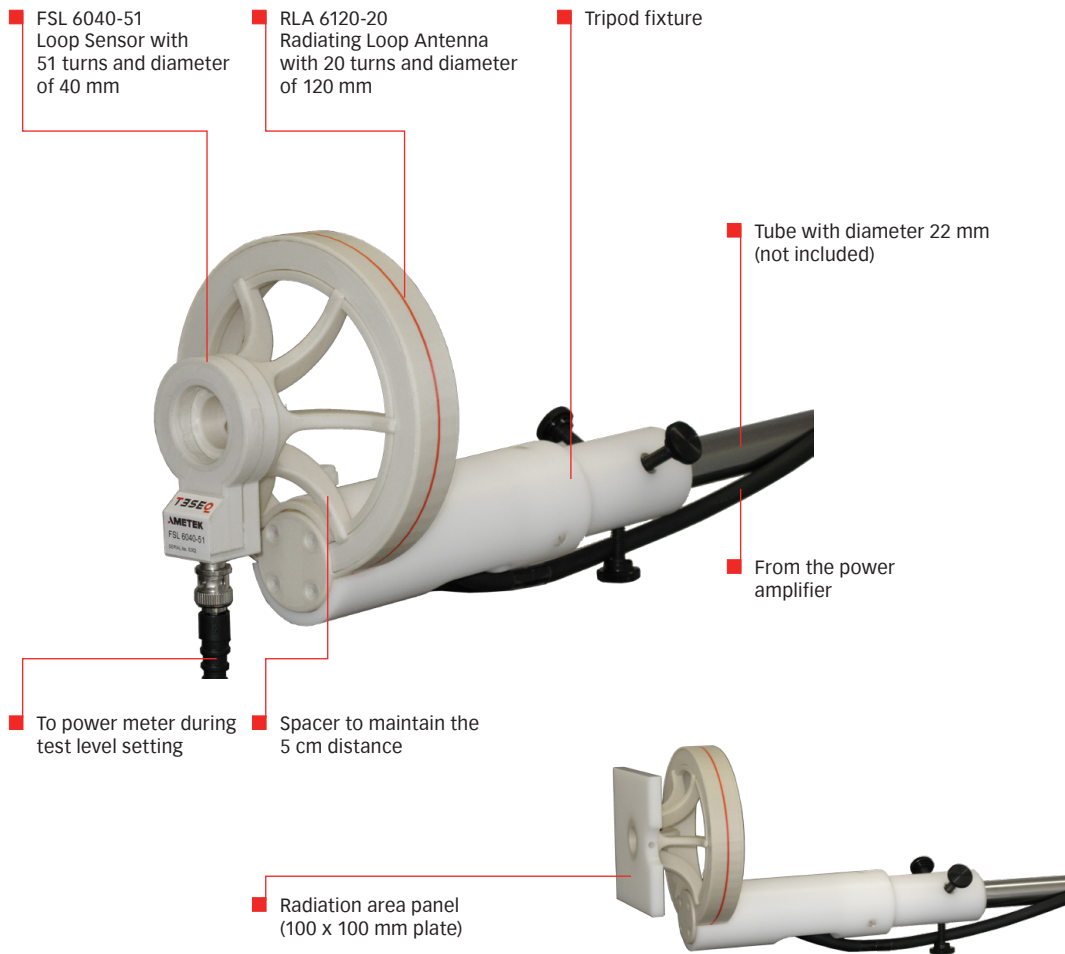

Figure 5: Construction of the product

## 5. CORRECTION FACTOR AND CONVERSION

### 5.1. Magnetic field

The receiving antenna is connected to a 50 ohm power meter and positioned 5 cm away from the transmitting antenna. The measured voltage or power is converted into magnetic field strength according to the following formula:

$$H = V_0 + k$$

with H = magnetic field strength in dB $\mu$ A/m  
 with  $V_0$  = voltage in dB $\mu$ V  
 with k = correction factor in dBS/m, dB1/( $\Omega^*$ m), dBA/(V\*m) or dB $\mu$ A/( $\mu$ V\*m)

The following formulas show the relation.

$$\text{dBS/m} = \text{dB1}/(\Omega^*m) = \text{dBA}/(V^*m) = \text{dB}\mu\text{A}/(\mu\text{V}^*m)$$

$$\text{dBA} = 20\log(A)$$

$$\text{dB}\mu\text{A} = 20\log(A) + 120$$

$$\text{dB}\mu\text{A} = \text{dBm} + 73$$

$$\text{dBm} = \text{dB}\mu\text{A} - 73$$

For example:

Voltage measured at 150 kHz = 116.8 dB $\mu$ V

Correction factor at 150 kHz = 31.5 dBS/m

Magnetic field strength = 116.8 dB $\mu$ V + 31.5 dBS/m = 148.3 dB $\mu$ A

Converting dB $\mu$ A/m in A/m:  $A/m = 10^{((\text{dB}\mu\text{A}/m) - 120)/20}$

Converting A/m in dB $\mu$ A/m:  $\text{dB}\mu\text{A}/m = 20 \log (A/m + 120)$

50 Ω Power meter		K factor (example)	Field strength		
dBμV	dBm		dBS/m	dBμA/m	A/m
60	-47	40	100	0.10	102
65	-42	40	105	0.18	107
70	-37	40	110	0.32	112
75	-32	40	115	0.56	117
80	-27	40	120	1.00	122
85	-22	40	125	1.78	127
90	-17	40	130	3.16	132
95	-12	40	135	5.62	137
100	-7	40	140	10.00	142
105	-2	40	145	17.78	147
110	3	40	150	31.62	152
115	8	40	155	56.23	157
120	13	40	160	100.00	162
125	18	40	165	177.83	167
130	23	40	170	316.23	172
135	28	40	175	562.34	177
140	33	40	180	1000.00	182

**Table 7: Conversion example for the receiving antenna**

The transmitting antenna is connected to a current source. With the help of the correction factor, the generated field strength can be calculated.

$$H = I + k$$

with H = magnetic field strength in A/m

with I = current in A

with k = factor of 120 mm coil in 1/m

Coil current	Coil factor (example)	Field strength		
		A/m	dB $\mu$ A/m	dBpT
0.001	75.6	0.076	97.6	99.6
0.05	75.6	3.8	131.5	133.5
0.1	75.6	7.6	137.6	139.6
0.5	75.6	37.8	151.5	153.5
1	75.6	75.6	157.6	159.6
2	75.6	151.2	163.6	165.6
3	75.6	226.8	167.1	169.1
4	75.6	302.4	169.6	171.6
5	75.6	378.0	171.5	173.5
6	75.6	453.6	173.1	175.1
7	75.6	529.2	174.5	176.5
8	75.6	604.8	175.6	177.6
9	75.6	680.4	176.7	178.7
10	75.6	756.0	177.6	179.6
11	75.6	831.6	178.4	180.4
12	75.6	907.2	179.2	181.2
13	75.6	982.8	179.8	181.8
14	75.6	1058.4	180.5	182.5
15	75.6	1134.0	181.1	183.1
16	75.6	1209.6	181.7	183.7
17	75.6	1285.2	182.2	184.2
18	75.6	1360.8	182.7	184.7
19	75.6	1436.4	183.1	185.1
20	75.6	1512.0	183.6	185.6

**Table 8: Conversion example for the transmitting antenna**

## 5.2. Current

The use of the current clamp requires the conversion via the transfer impedance or a correction factor.

### Transfer impedance in $\Omega$

The transfer impedance versus frequency allows the calculation of an unknown current in linear units using the following formula:

$$I = V_0 / Z_t$$

with  $I$  = current in A  
 with  $V_0$  = voltage in V  
 with  $Z_t$  = transfer impedance in  $\Omega$

For example:

Voltage measured at 100 kHz = 13 mV

Transfer impedance at 100 kHz = 4.53  $\Omega$

Current = 13 mV / 4.53  $\Omega$  = 2.87 mA

Relation of transmission factor S21, special example with transfer impedance of 1  $\Omega$  in a 50  $\Omega$  system:

$$S21 = 20 * \log_{10} (1 \Omega / 50 \Omega) = -33.98 \text{ dB}$$

with S21 in dB  
 with  $Z_t = 1 \Omega$ ,  $Z_t$  = transfer impedance in  $\Omega$   
 with  $Z_0 = 50 \Omega$ ,  $Z_0$  = system impedance in  $\Omega$

Relation transmission factor S21 and transfer impedance:

$$Z_t = 10^{((S21+33.98)/20)}$$

with S21 in dB  
 with  $Z_t$  = transfer impedance in  $\Omega$

Relation transmission factor S21 and insertion loss IL:

$$S21 = -IL$$

with S21 in dB  
 with IL in dB

Relation transmission factor S21 and correction factor k in dBS, dB1/ $\Omega$ , dB $\mu$ A/ $\mu$ V:

$$k = -S21 + 20 * \log_{10} (1 \Omega / 50 \Omega)$$

with S21 in dB

### Correction factor in dBS, dB1/ $\Omega$ , dB $\mu$ A/V

The correction factor is used when calculating an unknown current in the logarithmic scale. The following formula shows the relation.

$$I = V_0 + k$$

with  $I$  = current in dBA, dB $\mu$ A, etc.  
 with  $V_0$  = voltage in dBV, dB $\mu$ V, etc.  
 with  $k$  = correction factor in dBS, dB1/ $\Omega$ , dB $\mu$ A/ $\mu$ V

For example:

Voltage measured at 100 kHz = 78 dB $\mu$ V

Correction factor at 100 kHz = -13.13 dBS

Current = 78 dB $\mu$ V -13.13 dBS = 64.87 dB $\mu$ A

S21	Insertion loss	Transfer impedance	Correction factor	Transfer admittance	Correction factor
dB	dB	$\Omega$	dB $\Omega$	S, 1/ $\Omega$	dBs, dB1/ $\Omega$
14	-14	250	48	0.004	-48
0	0	50	34	0.02	-34
-14	14	10	20	0.1	-20
-20	20	5	14	0.2	-14
-34	34	1	0	1	0
-40	40	0.5	-6	2	6
-54	54	0.1	-20	10	20

**Table 9: Conversion example in 50  $\Omega$  system**



## 6. TECHNICAL SPECIFICATION

<b>RLA 6120-20 Radiating Loop Antenna</b>	
Frequency range	25 Hz to 150 kHz
Conversion factor	75.6 (current to magnetic field, example: 1 A generates 75.6 A/m or $9.5 \cdot 10^7$ pT/A)
Test distance	50 mm
Current	$\leq 15$ A (range DC to 150 kHz)
Loop diameter	120 mm
No. of turns	20
Wire diameter	approx. 2 mm, AWG12
Connector type	4 mm safety banana socket
Dimensions (W x H x D):	135 mm x 148 mm x 48 mm
Weight	approx. 360 g

<b>FSL 6040-51 Field Sensor Loop</b>	
Frequency range	25 Hz to 150 kHz
Loop diameter	40 mm
No. of turns	51
Wire diameter / type	approx. 0.07 mm / 7 strand, 41 AWG
Connector type	BNC, 50 $\Omega$
Correction factor	see graph and table
Dimensions (W x H x D):	51 mm x 90 mm x 25 mm
Weight	approx. 45 g

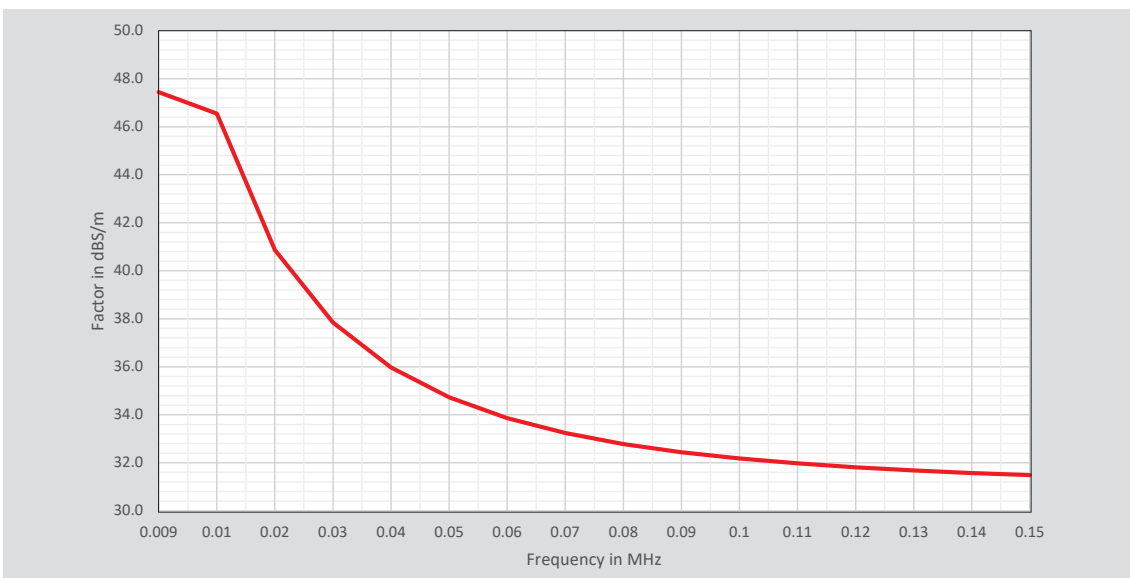

**Figure 6: FSL 6040-51 Field Sensor Loop typical correction factor**

f/kHz	dBS/m	f/kHz	dBS/m	f/kHz	dBS/m	f/kHz	dBS/m
0.009	47.44	0.045	35.29	0.081	32.74	0.117	31.86
0.01	46.55	0.046	35.17	0.082	32.71	0.118	31.84
0.011	45.74	0.047	35.05	0.083	32.67	0.119	31.83
0.012	45.01	0.048	34.94	0.084	32.63	0.12	31.81
0.013	44.35	0.049	34.83	0.085	32.60	0.121	31.80
0.014	43.73	0.05	34.72	0.086	32.57	0.122	31.78
0.015	43.17	0.051	34.62	0.087	32.53	0.123	31.77
0.016	42.64	0.052	34.53	0.088	32.50	0.124	31.76
0.017	42.15	0.053	34.43	0.089	32.47	0.125	31.74
0.018	41.69	0.054	34.34	0.09	32.44	0.126	31.73
0.019	41.26	0.055	34.25	0.091	32.41	0.127	31.72
0.02	40.86	0.056	34.17	0.092	32.38	0.128	31.71
0.021	40.48	0.057	34.09	0.093	32.35	0.129	31.69
0.022	40.12	0.058	34.01	0.094	32.33	0.13	31.68
0.023	39.78	0.059	33.93	0.095	32.30	0.131	31.67
0.024	39.46	0.06	33.86	0.096	32.27	0.132	31.66
0.025	39.16	0.061	33.79	0.097	32.25	0.133	31.65
0.026	38.87	0.062	33.72	0.098	32.22	0.134	31.64
0.027	38.59	0.063	33.65	0.099	32.20	0.135	31.63
0.028	38.33	0.064	33.59	0.1	32.18	0.136	31.62
0.029	38.08	0.065	33.52	0.101	32.15	0.137	31.61
0.03	37.85	0.066	33.46	0.102	32.13	0.138	31.60
0.031	37.62	0.067	33.40	0.103	32.11	0.139	31.59
0.032	37.40	0.068	33.35	0.104	32.09	0.14	31.58
0.033	37.20	0.069	33.29	0.105	32.07	0.141	31.57
0.034	37.00	0.07	33.24	0.106	32.05	0.142	31.56
0.035	36.81	0.071	33.19	0.107	32.03	0.143	31.55
0.036	36.63	0.072	33.13	0.108	32.01	0.144	31.54
0.037	36.45	0.073	33.09	0.109	31.99	0.145	31.53
0.038	36.29	0.074	33.04	0.11	31.97	0.146	31.52
0.039	36.13	0.075	32.99	0.111	31.96	0.147	31.51
0.04	35.97	0.076	32.95	0.112	31.94	0.148	31.51
0.041	35.82	0.077	32.90	0.113	31.92	0.149	31.50
0.042	35.68	0.078	32.86	0.114	31.90	0.15	31.49
0.043	35.55	0.079	32.82	0.115	31.89		
0.044	35.41	0.08	32.78	0.116	31.87		

**Table 10: FSL 6040-51 Field Sensor Loop typical correction factor**

<b>CSP 9160A Current Sensor</b>	
Frequency range:	9 kHz to 250 MHz
Insertion loss:	34 dB $\pm$ 2 dB (50 $\Omega$ system, 100 kHz to 120 MHz) typical $\pm$ 1 dB, see also the graphs
Transfer impedance, transducer factor:	as given in the graphs
Insertion impedance:	<1 $\Omega$
Signal output:	BNC socket
Max. primary current (aperture)	50 A <sub>RMS</sub> (CW), DC – 60 Hz 1.5 A <sub>RMS</sub> (CW), 9 kHz - 250 MHz
Window diameter (aperture):	25.4 mm
Dimensions (L x H x W) in mm:	105 x 80 x 38
Weight:	approx. 525 g
Dimensions of the storage case in mm:	260 x 70 x 210
Weight:	approx. 350 g

### CSP 9160A Typical transducer factor and insertion loss, --- limit

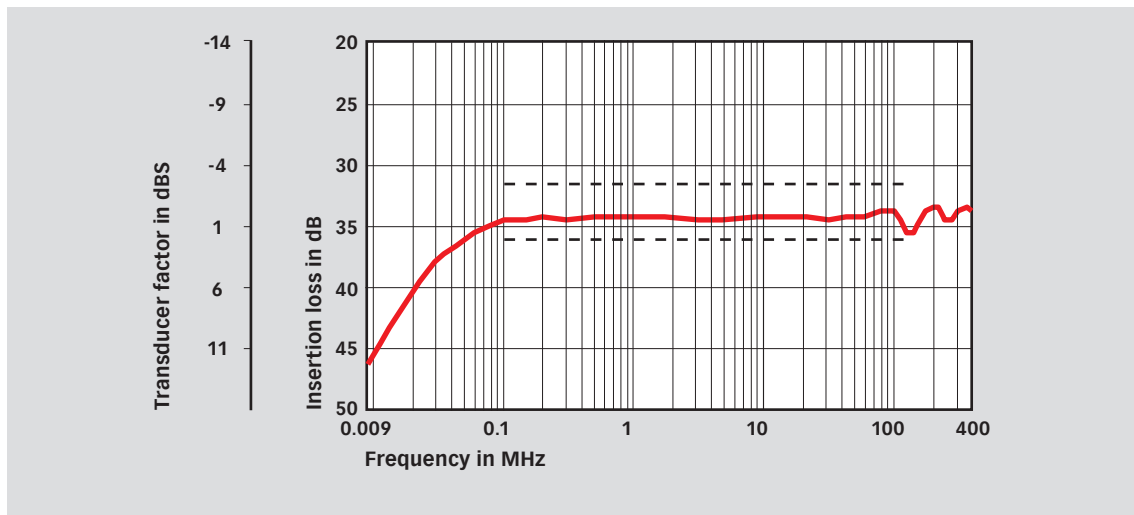

### Environment specifications

Classification	Indoor use only
Operation temperature	0 °C to +40 °C
Storage and transport temperature	-10 °C to +60 °C
Relative humidity	up to 90 % (no moisture condensation)

### Mechanical dimensions of the LAS 6120

Dimensions (W x H x D):	350 mm x 125 mm x 275 mm
Weight:	approx. 2.0 kg

## **7. MAINTENANCE**

### **7.1. General**

The LAS 6120 needs no special maintenance. The maintenance is limited to the cleaning of the contacts. The life time of the connectors is limited because of the contact durability. Teseq can replace the worn out connectors.

No modifications are to be carried out on the LAS 6120 and accessories by the user.  
It is recommended to send the unit to a AMETEK Service Centre once a year for recalibration.

### **7.2. Cleaning**

The cleaning shall be done with dry cloth. If a wet cleaning would become necessary, make sure that no humidity will enter inside of the unit and clean the instrument housing with a damp cloth using a little mild, non-abrasive household cleanser if necessary.

Chemicals must not be used for cleaning purposes

## **8. DISPOSAL**

The unit is constructed that it can be dismantled right down to the component level.

**Manufacturer****AMETEK CTS Europe GmbH**

12623 Berlin, Germany  
 Landsberger Str. 255  
 T +49 30 5659 8835  
 F +49 30 5659 8834  
 customercare.cts@ametek.com  
**www.ametek-cts.com**

**China****AMETEK Commercial Enterprise (Shanghai) Co., Ltd. Beijing Branch**

T +8610 8526 2111  
 F +8610 8526 2141  
 sales.cts.cn@ametek.com

**Japan****AMETEK Co., Ltd. Nagoya Office**

T +81 52 709 5501  
 cts-japan.sales@ametek.com

**Taiwan****AMETEK Taiwan Corp. Ltd**

T +886 3 575 0099  
 taiwansales.cts@ametek.com

**USA****AMETEK CTS US**

T +1 732 417 0501  
 Toll free +1 888 417 0501  
 usasales.cts@ametek.com

**Europe****AMETEK CTS Europe GmbH**

T +49 2307 26070-0  
 sales.cts.eu@ametek.com

**Singapore****AMETEK Singapore Pte Ltd**

T +65 6484 2388  
 singapore.sales.cts@ametek.com

To find your local partner within  
 Teseq's global network, please go to  
**www.ametek-cts.com**



© August 2022 Teseq®  
 Specifications subject to change without notice.  
 All trademarks recognized.

AMETEK CTS Europe GmbH is an ISO-registered company. Its products are designed and manufactured under the strict quality requirement of the ISO 9001.

This document has been carefully checked. However, AMETEK CTS Europe GmbH does not assume any liability for errors or inaccuracies.