

Model 3810/2

Line Impedance Stabilization Network (LISN)

User Manual



ETS-Lindgren L.P. reserves the right to make changes to any product described herein in order to improve function, design, or for any other reason. Nothing contained herein shall constitute ETS-Lindgren L.P. assuming any liability whatsoever arising out of the application or use of any product or circuit described herein. ETS-Lindgren L.P. does not convey any license under its patent rights or the rights of others.

© Copyright 1996–2010 by ETS-Lindgren L.P. All Rights Reserved. No part of this document may be copied by any means without written permission from ETS-Lindgren L.P.

Trademarks used in this document: The *ETS-Lindgren* logo is a trademark of ETS-Lindgren L.P.

Revision Record | MANUAL 3810/2 | Part #399197, Rev. D



Revision	Description	Date
A–C	<ul style="list-style-type: none">• Initial Release• Edits/updates• Edits/updates	February, 1996
D	Rebrand; added <i>EC Declaration of Conformity</i>	July, 2010

Table of Contents

Notes, Cautions, and Warnings.....	v
Safety Symbol Definitions.....	v
1.0 Introduction	7
ETS-Lindgren Product Information Bulletin	7
2.0 Maintenance	9
Service Procedures	10
3.0 Specifications.....	11
Electrical Specifications	11
Physical Specifications	12
4.0 Installation and Application.....	13
Front Panel Connectors and Controls	15
BNC Connector.....	15
Line Select Switch	15
RF Ground.....	15
Earth Line Choke Switch	16
AC Receptacle.....	16
Artificial Hand.....	16
Back Panel Connectors	17
Power Input.....	17
RF Ground.....	17
5.0 Data	19
6.0 Schematic	21
Appendix A: Warranty	23
Appendix B: EC Declaration of Conformity	25

This page intentionally left blank.

Notes, Cautions, and Warnings

	<p>Note: Denotes helpful information intended to provide tips for better use of the product.</p>
	<p>Caution: Denotes a hazard. Failure to follow instructions could result in minor personal injury and/or property damage. Included text gives proper procedures.</p>
	<p>Warning: Denotes a hazard. Failure to follow instructions could result in SEVERE personal injury and/or property damage. Included text gives proper procedures.</p>



See the ETS-Lindgren *Product Information Bulletin* for safety, regulatory, and other product marking information.

Safety Symbol Definitions

	<p>EQUIPOTENTIALITY</p> <p>Identifies the terminals, when connected together, to bring various parts of a system to the same potential, not necessarily being the earth (ground) potential, e.g. for local bonding.</p>
---	--



See the ETS-Lindgren *Product Information Bulletin* for safety, regulatory, and other product marking information.

This page intentionally left blank.

1.0 Introduction

The ETS-Lindgren **Model 3810/2 Line Impedance Stabilization Network (LISN)** is a two-channel low pass filter network designed to isolate the Equipment Under Test from an external power source while steering any radio frequency signals from the power line to a 50-ohm port.



Model 3810/2 Front View

The conducted emissions measurements may be made in accordance with regulatory compliance standards



The Model 3810/2 was designed and tested in accordance with IEC Publication 1010, Safety Requirements for Electronic Measuring Apparatus, and is supplied in a safe condition.

ETS-Lindgren Product Information Bulletin

See the ETS-Lindgren *Product Information Bulletin* included with your shipment for the following:

- Warranty information
- Safety, regulatory, and other product marking information
- Steps to receive your shipment
- Steps to return a component for service
- ETS-Lindgren calibration service
- ETS-Lindgren contact information

This page intentionally left blank.

2.0 Maintenance

CAUTION

Before performing any maintenance, follow the safety information in the ETS-Lindgren Product Information Bulletin included with your shipment.

WARNING

Only trained service personnel should perform adjustments and/or service procedures.



Inside the Model 3810/2 are **LETHAL** voltages with which you could come into contact. Capacitors inside the unit may still be **CHARGED** even when the unit is disconnected from power.

Before Servicing contact ETS-Lindgren. Servicing (or modifying) the unit yourself may void your warranty. If you attempt to service the unit yourself, disconnect all electrical power before starting. There are voltages at many points in the instrument which could, if contacted, cause personal injury. Only trained service personnel should perform adjustments and/or service procedures upon this instrument.



Maintenance of the Model 3810/2 is limited to external components such as cables or connectors.

Clean the exterior of the cabinet using a damp cloth and mild cleaner. Always unplug the unit before cleaning.

To prevent electrical shock, do not remove cover.

If you have any questions concerning maintenance, contact ETS-Lindgren Customer Service.

Service Procedures

For the steps to return a system or system component to ETS-Lindgren for service, see the *Product Information Bulletin* included with your shipment.

3.0 Specifications

Electrical Specifications

Frequency Range:	9 kHz–30 MHz (VDE 0876 specified curve \pm 20%)
Network Inductance:	50 μ H / 250 μ H
Network Impedance:	50 Ω
Current Rating:	10 Amperes
Maximum AC Voltage	
3810/2NM:	125 VAC 60 Hz
3810/2BR:	250 VAC 50 Hz
3810/2SH:	250 VAC 50 Hz
3810/2AS:	250 VAC 50 Hz
Output Connectors	
3810/2NM:	NEMA 5-15R
3810/2BR:	British BS1363
3810/2SH:	Schuko CEE 7/7
3810/2AS:	AS 3112
Input Connector:	IEC-320 Type 3-wire Inlet
Environmental	
Installation:	Indoor use only
Altitude:	15000 ft (4572 m) max
Temperature:	0°C to 40°C (32°F to 104°F)
Relative Humidity:	80% up to 31°C (87.8°F) decreasing linearly to 50% at 40°C (104°F)

Physical Specifications

Height:	124 mm (4.9 in)
Width:	218 mm (8.6 in)
Depth:	381 mm (15.0 in)
Weight:	5.4 kg (12.0 lb)

4.0 Installation and Application

CAUTION

Before connecting any components, follow the safety information in the ETS-Lindgren *Product Information Bulletin* included with your shipment.

CAUTION

Overcurrent protection is not provided in the Model 3810/2. The unit must be connected to a power mains which has appropriately rated mains protection installed.



The Model 3810/2 is provided with a protective earthing ground integral to the power cord. The mains plug should only be connected to an outlet which incorporates a protective earth contact. Due to the high leakage current to ground inherent in this type of equipment, it is necessary to install a supplemental protective earthing wire from the protective earth terminal on the rear panel to an appropriate earthing point on the power mains. This earthing point should be determined by an electrician authorized to perform such work by appropriate code or law. Any interruption of the protective conductor inside or outside of the unit is likely to make the Model 3810/2 dangerous. Intentional interruption is prohibited. The supplemental ground wire is supplied with the unit.

CAUTION

The Model 3810/2 is provided with resistors to help bleed off high voltage transients, but it is advisable to connect the input and output connectors to their proper power lines and loads before connecting the monitor port to the measurement instrumentation; otherwise, power surges or transients can damage the test instrumentation mixers or attenuators.

The Model 3810/2 Line Impedance Stabilization Network (LISN) is designed for use in Installation Category II and Pollution Degree II per IEC-1010 and IEC-664. When installing in a cabinet, make sure that the convection around the product is not restricted. The ambient temperature outside the cabinet must be less than the maximum operating temperature of the Model 3810/2 by 4°C for every 100 watts dissipated in the cabinet. If the total power dissipated in the cabinet is greater than 800 watts, then forced convection must be used.

The Model 3810/2 is nominally designed for a 10 ampere current capacity. Maximum line-to-line voltage must not exceed the voltage rating of the power outlet provided on the front panel. See *Specifications* on page 11 for the applicable maximum value.

Front Panel Connectors and Controls

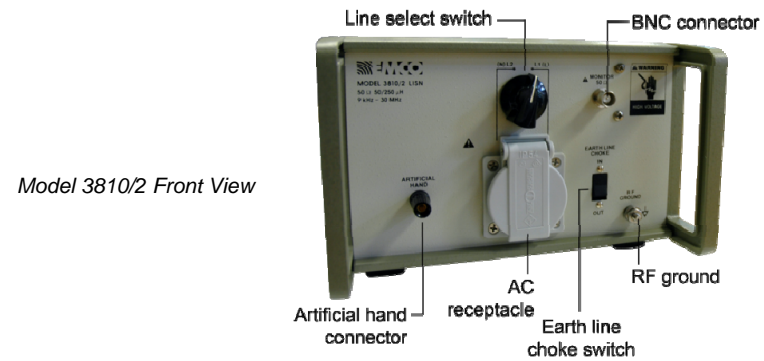

BNC CONNECTOR

Connect the Model 3810/2 to the spectrum analyzer or EMI receiver through the BNC connector.

LINE SELECT SWITCH

Select the line to be monitored by the two-position selector switch. The line not selected is internally terminated into 50 ohms. Switching between the two lines will not generate transients.



Remove the BNC connection before disconnecting power.

RF GROUND

The Model 3810/2 is provided with an RF bonding stud on both the front and rear panels. The unit should be bonded to a ground plane in normal operation.

EARTH LINE CHOKE SWITCH

The safety ground isolation choke selector switch switches the 1.6 mH earth line choke IN and OUT of the safety ground circuit. The ground choke is designed and manufactured with sufficient capacity to conduct the maximum current rating of the Model 3810/2 and at no time is the safety ground of the unit compromised. The earth line choke avoids a double RF ground connection (safety ground and measurement ground) in the conducted emissions test setup.

AC RECEPTACLE

Connect the Equipment Under Test (EUT) to the panel-mounted AC receptacle. The style of receptacle is determined by the model specified. Following are the standard output receptacle types:

- NEMA (Type 5-15R)
- Schuko (Type CEE 7/7)
- British Standard (BS 1363)
- Australian (AS 3112)

ARTIFICIAL HAND

In conformance with EN55014 and BS800, the artificial hand connection is used to test handheld equipment that is provided without earth connections.

Back Panel Connectors

Model 3810/2 Back View

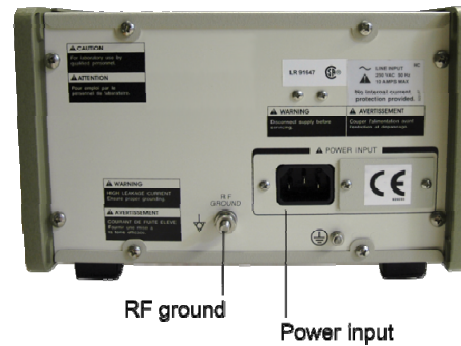

POWER INPUT

The input power connection is made through the IEC-320 type power inlet. This three-wire input power connector is rated at 10 amperes maximum. In case of emergency, power can be removed from the unit by removing the power connection at the Model 3810/2 input. Alternately, a properly rated circuit breaker or switch which removes mains power from the unit can be installed in proximity to the unit.

RF GROUND

See description on page 15.

This page intentionally left blank.

5.0 Data

Graphs of the calibration data for each measurement port of the Model 3810/2 Line Impedance Stabilization Network (LISN) are included with the unit. The graphs provide individual plots of both impedance and insertion loss data. Impedance is plotted in a semi-log format where frequency is displayed on the horizontal from 9 kHz to 30 MHz. The vertical has a range of 0 ohms to 100 ohms and represents the measured impedance of the unit. The insertion loss is also plotted with frequency on the horizontal from 9 kHz to 30 MHz. The vertical of the graph has a range of -9 dB to 1 dB and represents the measured insertion loss of the Model 3810/2.

A *Certificate of Calibration Conformance* is provided with each Model 3810/2.

This page intentionally left blank.

6.0 Schematic



- Resistance values shown in ohms.
- Ground choke select switch (S1) shown in the IN position.
- Line monitor select switch (S2) shown in the L2 (NTL) position.
- NEMA type output connector shown.

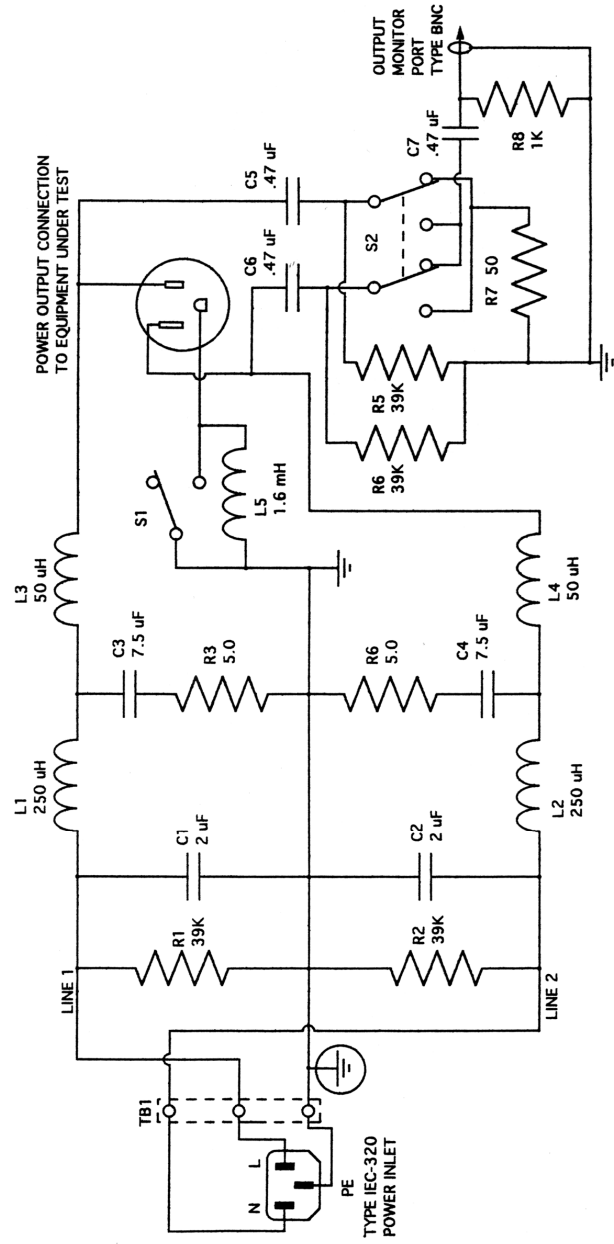

Appendix A: Warranty



See the *Product Information Bulletin* included with your shipment for the complete ETS-Lindgren warranty for your Model 3810/2.

DURATION OF WARRANTIES FOR MODEL 3810/2

All product warranties, except the warranty of title, and all remedies for warranty failures are limited to two years.

Product Warranted	Duration of Warranty Period
Model 3810/2 Line Impedance Stabilization Network (LISN)	2 Years

This page intentionally left blank.

Appendix B: EC Declaration of Conformity



EUROPEAN COMMUNITY DECLARATION OF CONFORMITY

The EC Declaration of Conformity is the method by which EMC Test Systems, L.P. declares that the equipment listed on this document complies with the EMC directive.

Factory:

EMC Test Systems, L.P.
P.O. Box 80589
Austin, Texas USA
78708-0589

Issued by:

EMC Test Systems, L.P.
P.O. Box 80589
Austin, Texas USA
78708-0589

The products manufactured under the EMCO product name and listed below are eligible to bear the EC Mark:

Model 3810/2SH Line Impedance Stabilization Network
Model 3810/2BR Line Impedance Stabilization Network
Model 3810/2NM Line Impedance Stabilization Network
Model 3810/2AS Line Impedance Stabilization Network

Applicable Requirements:

Standard	Criteria
IEC1010	Safety requirements for electrical equipment for measurement, control and laboratory use
EN55022	Passive device. EMC testing is not required.

Authorized Signatories

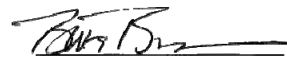
Bruce Butler, General Manager

Charles Garrison, Quality Assurance

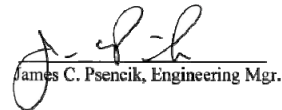
James C. Psencik, Engineering Mgr.

Date of Declaration

The authorizing signature on the EC Declaration of Conformity document authorizes EMC Test Systems, L.P. to affix the CE mark to the indicated product. CE marks placed on these products will be distinct and visible. Other marks or inscriptions liable to be confused with the CE mark will not be affixed to these products. EMC Test Systems, L.P. has ensured that appropriate documentation shall remain available on premises for inspection and validation purposes for a period of no less than 10 years.