

# User Manual CDN2000-06-25

Coupling Network for:

- Surge: 1.2/50 $\mu$ s up to 6 kV and 8/20 current up to 3 kA
- Ring Wave: up to 6 kV
- EFT: up to 4.4 kV, common and differential mode
- Damped Oscillatory Wave: up to 3kV

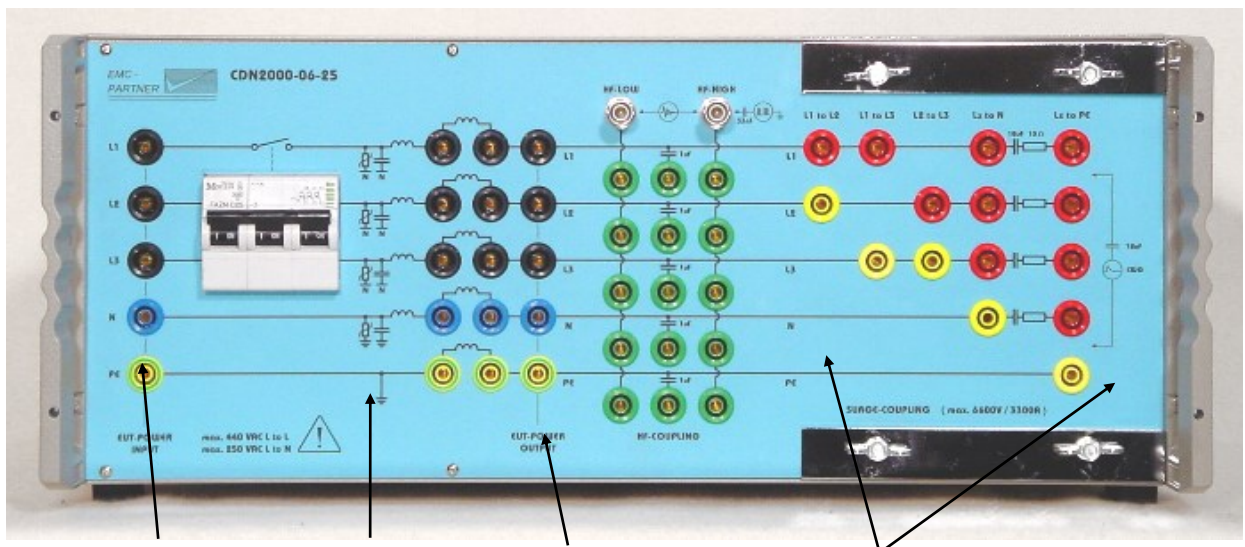

Supply input

Filter and  
overcurrent trip

Supply output

Switch field coupling  
impedance and path

**Title:**  
**Date:**  
**Division Manager:**  
**Quality Manager:**  
**Revised**

CDN2000-06-25 Coupling Network  
16.07.99  
M. Lutz  
R. Henz  
**06. May 2011**

Three Phase Coupling Decoupling Network - Manually Operated  
**For EFT, SURGE, RING WAVE, OSCI Coupling**

|          |  |           |
|----------|--|-----------|
| <b>1</b> | <b>DESCRIPTION</b>   | <b>5</b>  |
| 1.1      | <b>The different application of the CDN2000-06-25</b>                        | <b>5</b>  |
| 1.1.1    | "CWG Combination Wave Generator"   | 5         |
| 1.1.2    | Ring wave test 0,5 $\mu$ s / 100 kHz   | 7         |
| 1.1.3    | Electric fast transient 5/50 ns  | 10        |
| 1.1.4    | Damped Oscillatory Wave 100 kHz or 1 MHz                                     | 10        |
| 1.2      | <b>Impulse testers useably with CDN2000-06-25</b>                            | <b>12</b> |
| 1.2.1    | MIG testers with 6 kV output voltage   | 12        |
| 1.2.2    | Impulse testers TRA  | 12        |
| 1.3      | <b>Technical data</b>  | <b>13</b> |
| 1.3.1    | CDN2000-06-25  | 13        |
| 1.3.2    | Block diagram CDN2000  | 15        |
| 1.4      | <b>Mechanical dimensions</b>   | <b>16</b> |
| 1.4.1    | CDN2000-06-25 Tester   | 16        |
| 1.5      | <b>Power supply</b>  | <b>16</b> |
| 1.6      | <b>Accessories delivered with the CDN2000-06-25</b>                          | <b>17</b> |
| <b>2</b> | <b>SAFETY</b>  | <b>19</b> |
| 2.1      | <b>Safety standards</b>  | <b>19</b> |
| 2.2      | <b>Climatic Conditions</b>   | <b>19</b> |
| 2.3      | <b>Precautionary measure during use</b>                                      | <b>20</b> |
| 2.4      | <b>Electromagnetic Compatibility</b>   | <b>20</b> |
| 2.5      | <b>The manual is an integral part of the equipment. Refer to the manual.</b> | <b>20</b> |
| <b>3</b> | <b>MECHANICAL STRUCTURE</b>  | <b>21</b> |
| 3.1      | <b>General</b>   | <b>21</b> |
| <b>4</b> | <b>PANELS OF THE CDN2000-06-25</b>   | <b>23</b> |
| 4.1      | <b>Front panel of the CDN2000-06-25</b>                                      | <b>23</b> |
| <b>5</b> | <b>PREPARATION FOR OPERATION</b>   | <b>25</b> |
| 5.1      | <b>Attention, Refer to Manual</b>  | <b>25</b> |
| 5.2      | <b>Operators and Service Personnel</b>                                       | <b>25</b> |
| 5.3      | <b>Checks before operation</b>   | <b>25</b> |
| 5.3.1    | Optical verification of the CDN2000-06-25                                    | 25        |
| 5.3.2    | EUT Power, Power source for the EUT  | 26        |

---

|           |  |           |
|-----------|--|-----------|
| 5.3.3     | I/O lines coupling                                   | 26        |
| 5.3.4     | SURGE coupling set up                                | 27        |
| 5.3.5     | Ring Wave coupling set up                            | 27        |
| 5.3.6     | EFT coupling set up                                  | 28        |
| 5.3.7     | Damped oscillatory coupling set up                   | 29        |
| <b>6</b>  | <b>TESTING WITH THE CDN2000-06-25</b>                | <b>31</b> |
| 6.1       | Quickstart of TRA or MIG together with CDN2000-06-25 | 31        |
| 6.1.1     | MIG0603Inx Operation with CDN2000-06-25              | 31        |
| <b>7</b>  | <b>MAINTENANCE AND SERVICING</b>                     | <b>33</b> |
| 7.1       | Maintenance  | 33        |
| 7.2       | Verification of the CDN2000-06-25 by the user        | 33        |
| 7.2.1     | Combination Wave Tester                              | 33        |
| 7.2.2     | Ring Wave Tester                                     | 34        |
| 7.3       | Verification of the CDN2000-06-25 at EMC PARTNER     | 34        |
| <b>8</b>  | <b>WHAT MUST BE DONE FOLLOWING FAILED OPERATION</b>  | <b>35</b> |
| 8.1       | Service; Repairs                                     | 35        |
| 8.2       | Spare parts list                                     | 35        |
| 8.3       | Hints when varistors have been damaged in a CDN      | 35        |
| 8.4       | Service department of EMC PARTNER AG                 | 37        |
| 8.5       | Information for dismantling                          | 37        |
| 8.6       | Parts which can be recycled                          | 37        |
| 8.7       | Parts which can not be recycled                      | 37        |
| <b>9</b>  | <b>RECYCLING / DISPOSAL</b>                          | <b>39</b> |
| 9.1       | RoHS directive 2002/95/EG                            | 39        |
| 9.2       | WEEE directive 2002/96/EG                            | 39        |
| 9.3       | Information for dismantling                          | 39        |
| 9.4       | Parts which can be recycled                          | 39        |
| 9.5       | Parts which can not be recycled                      | 39        |
| <b>10</b> | <b>APPENDIX AND CORRECTION</b>                       | <b>41</b> |
| 10.1      | Appendix   | 41        |
| 10.1.1    | Verification of the 1,2/50; 8/20 $\mu$ s waveform    | 41        |

|             |  |           |
|-------------|--|-----------|
| <b>10.2</b> | <b>Correction</b>                                    | <b>42</b> |
| 10.2.1      | TRA2000 with CDN2000 SURGE Synchronisation           | 42        |
| <b>11</b>   | <b>GLOSSARY</b>                                      | <b>43</b> |
| <b>12</b>   | <b>INDEX</b>   | <b>45</b> |
| <b>13</b>   | <b>ANNEX</b>   | <b>48</b> |
| 13.1        | Damped oscillatory on power supply                   | 48        |
| 13.2        | Damped oscillatory on I/O lines                      | 48        |
| 13.3        | Assembly Instruction to MC Connectors                | 49        |
| 13.4        | Wire connection between MIG0603OMI and CDN2000-06-25 | 51        |

## 1 Description

The impulse testers MIG0603IN, MIG0603-OS, MIG1203-CWG, TRA1000, etc. can be extended with a manual operated three-phase coupling network CDN2000. With regard to its price and dimensions, the three-phase coupling network is a genuine alternative to mains coupling filters available on the market today. The CDN2000 can be used for SURGE, Ring Wave, EFT, Damped oscillation superimposing. The desired coupling path must be plugged on the front panel by hand. The coupling network fulfils the requirements laid down in the IEC61000-4-4, IEC 61000-4-5, IEC 61000-4-12, IEC 61000-4-18 standards.

The most important characteristics of the three-phase coupling network are

- Simple, clear selection of coupling path for SURGE for common and differential mode coupling
- Simple, clear selection of coupling path for EFT and Damped Oscillatory Waves
- Handy coupling network for up to 25 A per phase.
- The units can be placed below MIG or TRANSIENT testers.
- Contact-protected construction.
- All plug connections to power supply and EUT are arranged on the front plate.

### 1.1 The different application of the CDN2000-06-25

#### 1.1.1 "CWG Combination Wave Generator"

The combination wave generator has been defined first for **Electro Magnetic Compatibility** EMC tests up to 4 kV in the document IEC 61000-4-5 or IEEE 587. EMC test must be carried out on powered equipment. There are several reasons for performing powered test:

- From a standpoint of a good practice, it is best to perform laboratory tests in a manner that most closely simulates the actual service environment.
- It is the applied ac that furnishes the energy following the surge, that can establish sustained arcing faults, tracking on insulation, destruction of printed wiring, and so on
- The application of normal ac power generally rises the EUT to an initial level of stress. Without power current following a surge-induced flashover, the resulting defect might not be detected.

The CWG tester generate a waveform 1,2/50  $\mu$ s or a current waveform of 8/20  $\mu$ s at clamping status of the protection circuit. Traditionally, the 1,2/50  $\mu$ s voltage waveform was used for testing the basic impulse level of insulation, which is approximately an open circuit until the insulation fails. The 8/20  $\mu$ s current waveform was used to inject large currents into surge protective devices. Since both the open circuit voltage and short circuit current are different aspects of the same phenomenon, such as an overstress caused by lightning, it was necessary to combine them to a single waveform when the load is not known in advance.

Generators to carry out combination wave tests

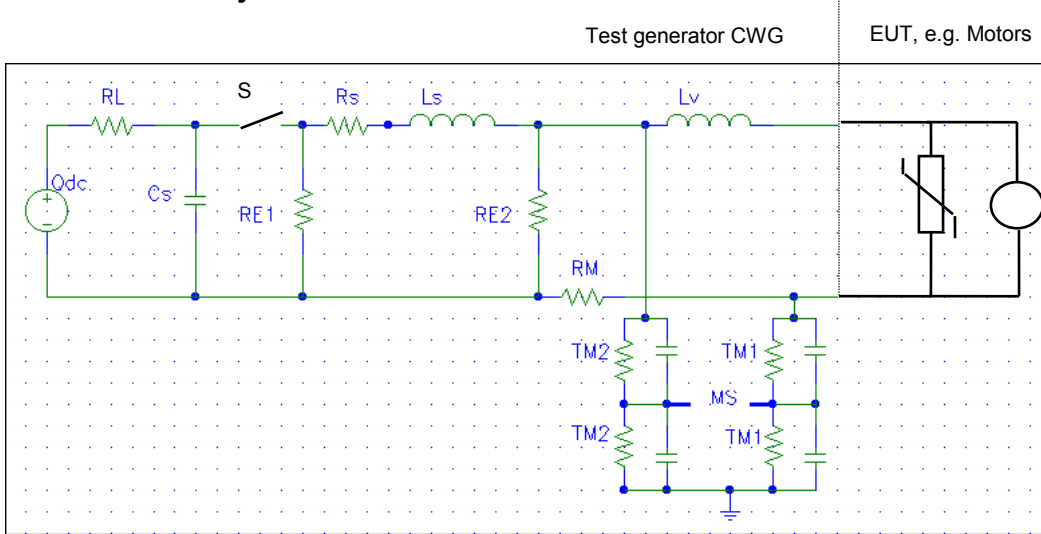

Figure: 1.0.3-1

Legend:

|     |                              |     |                             |     |                     |
|-----|------------------------------|-----|-----------------------------|-----|---------------------|
| RL  | Charging resistor            | Cs  | Impulse capacitor           | S   | High voltage switch |
| RE1 | Discharge resistor           | Ls  | Inductance of the generator | Rs  | Serial resistor     |
| RM  | Shunt                        | RE2 | Discharge resistor          | TM1 | Divider             |
| Lv  | Inductance of the connection | MS  | Measurement equipment       | TM2 | Divider             |

A dc source charges the capacitors within the different modules via the charging resistors. Closing the switch S discharge the capacitors into the parallel branches RE1, RE2 and EUT. When the EUT has a high impedance the CWG generates a voltage rise defined by the serial inductance Ls and by the parallel resistor RE2. The half value time is determined by Cs and the both RE1 // RE2. When the EUT has a low impedance the generated current is determined by the elements Cs, Ls, Rs and the EUT.

The current and voltage waveforms are defined in IEC 61000-4-5 as follows:

Waveshapes and tolerances

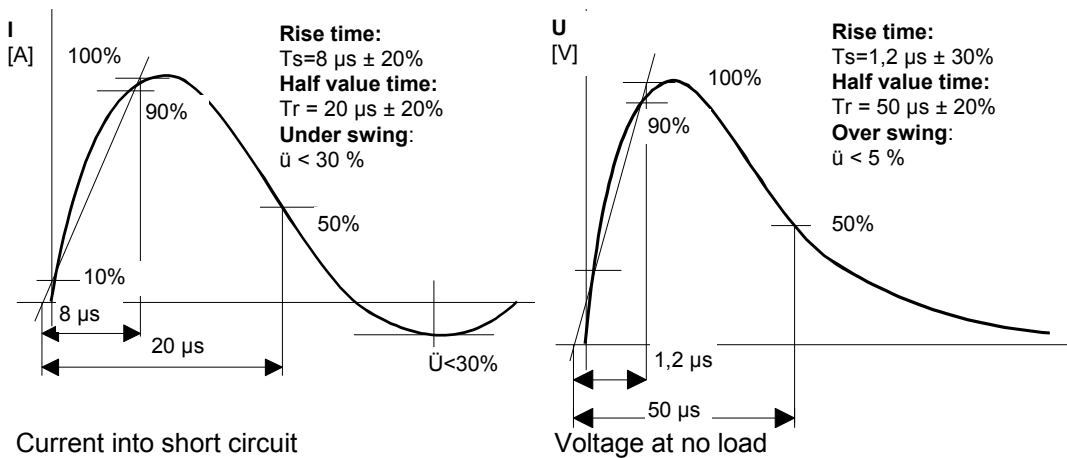

Figure: 1.0.1-2

The waveforms are verified in open circuit (voc) and short circuit (isc). No load limitation exists, because for different load impedance (EUT) the waveforms are within the open circuit voltage waveform and the short circuit current waveform.

### Superimposing surge onto power supply

To superimpose the surge pulses onto power line supply, coupling filters must be used. The aim of the coupling filter is to couple the generated surge waveform without deformation of rise time, half value time and amplitude onto the operated EUT and to protect the auxiliary equipment from surge pulses.

When surges are superimposed onto power supply lines, the synchronisation angle must be chosen to correspond to the half wave of the power supply. The picture below shows that pseudo tests can be carried out, when the synchronisation angle is not correctly selected. When a positive surge is superimposed at  $270^\circ$ , the clamping voltage of the varistor is not reached and no real test is carried out.

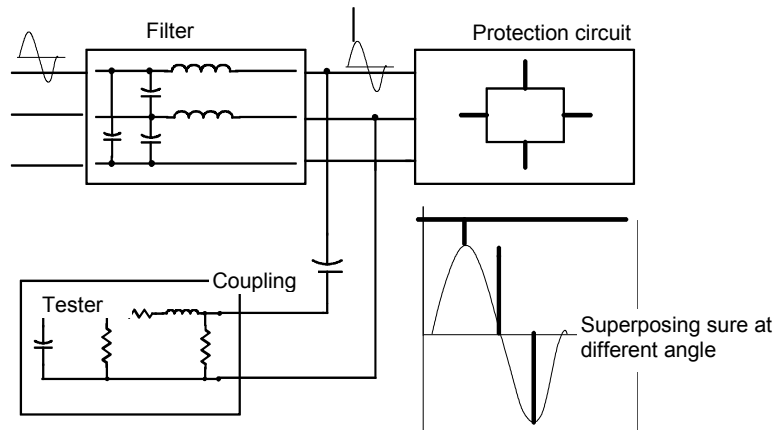

Figure: 1.0.1-3

### 1.1.2 Ring wave test 0,5 $\mu$ s / 100 kHz

#### Introduction:

The ring wave is a typical oscillatory transient, induced in low voltage cables due to the switching of electrical networks and reactive loads, faults and insulation breakdown of power supply circuits or lightning. The ring wave is representative of a wide range of electromagnetic environments of residential, as well as industrial, installations; it is suitable for checking the immunity of equipment in respect of the above mentioned phenomena.

Another cause of the ring wave, lightning, is characterised by a unidirectional waveform (standards 1,2/50; 8/20  $\mu$ s); the circuits subjected to its indirect effect ( inductive coupling among lines) are mainly influenced by the derivative of the primary pulse; the coupling mechanism, from its original frequency spectrum, gives rise to oscillations, the characteristics of which depend on the reactive parameters of the ground circuits, on metal structures involved in the lightning current flow, in addition to the propagation in the low voltage lines involved (see figure below).

ANSI / IEEE; IEC 61000-4-12  
CWG versus Ring wave

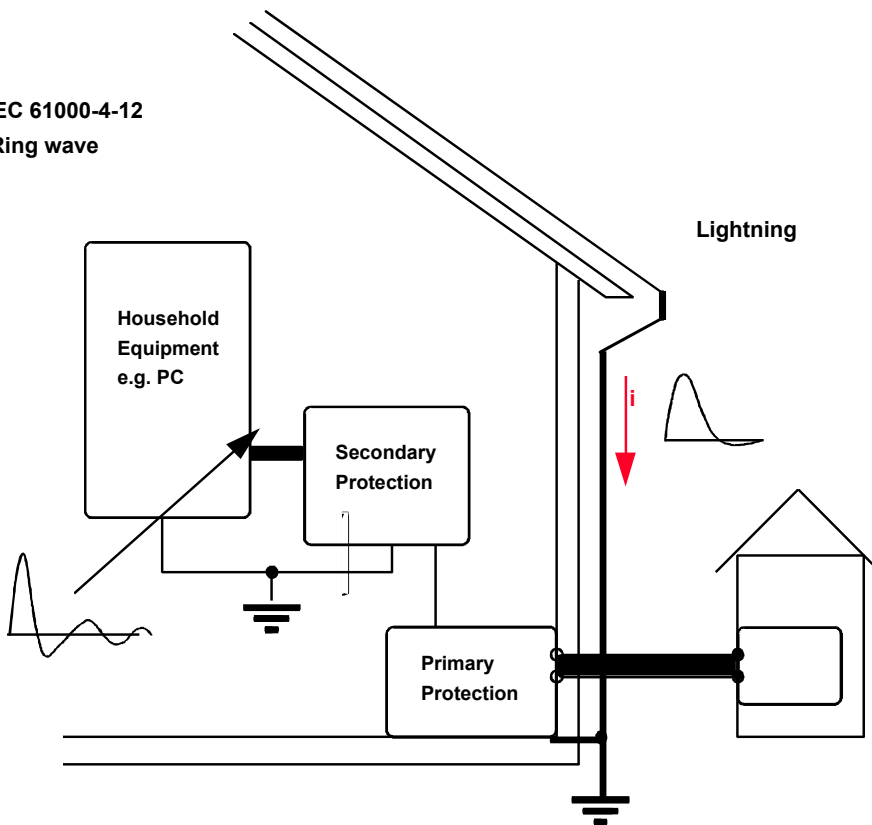

Figure: 1.0.2-1

The ring wave appears at the terminals of equipment (equipment ports) as a consequence of switching in power and control lines, as well as a consequence of lightning. The single event type and the decaying oscillatory waveform are the most significant parameters of this test.

Ring Wave Generator

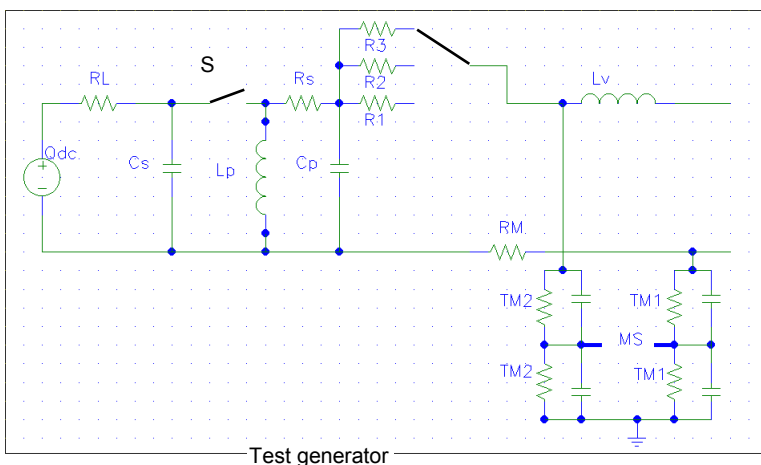

Figure: 1.0.2-2

Legend:

- |    |                     |    |                              |      |                            |
|----|---------------------|----|------------------------------|------|----------------------------|
| RL | Charging resistor   | Cs | Impulse capacitor            | S    | High voltage switch        |
| MS | Measuring equipment | Lp | Inductance of the generator  | Rs   | Serial resistor            |
| RM | Shunt               | Lv | Inductance of the connection | R1-3 | Current limiting resistors |
| TM | Dividers            | Cp | Parallel capacitor           |      |                            |



A dc source charges the impulse capacitor  $C_s$  to a programmed voltage. The high voltage switch  $S$  links impulse capacitor to the impulse shaping network. Depending on energy and voltages it can be a mechanical or an electronic switch. The waveform is mainly influenced by the network of the generator.

### Voltage and Current waveform and tolerances

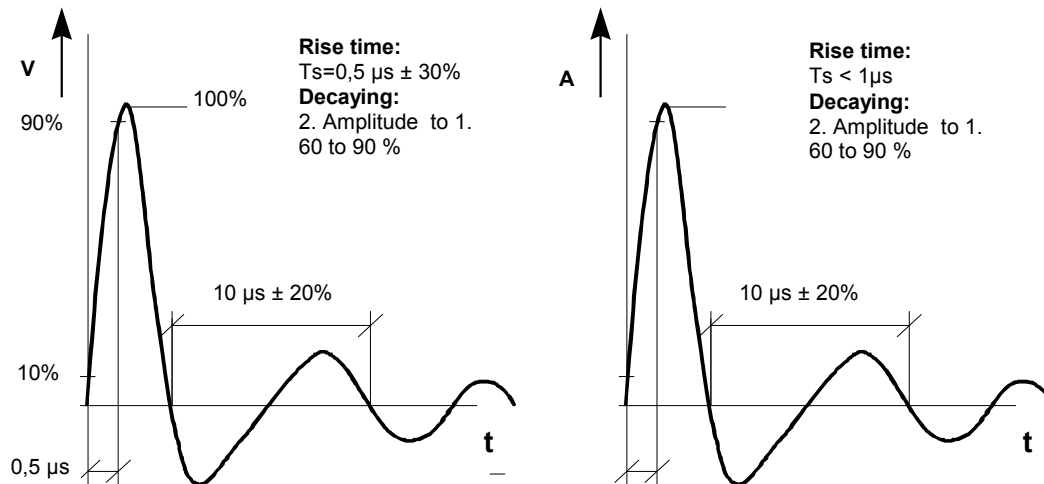

Figure: 1.0.2-3

### Relevant parameters for testing.

- **Repetition rate**

The repetition rate of the transient is directly related to the frequency of occurrence of the primary phenomenon; it is higher whenever the primary cause is the load switching in control lines, and less frequent in the case of faults and lightning; the occurrence may range from 1/s to 1/month

- **Phase angle**

Equipment failures related to ring wave on power supply sources can depend on the phase angle of the a.c. voltage sine wave at which the transients are applied. When a protection element sparks over during a ring wave test, power-follow might occur. Power-follow is the current from the connected power source that flows through a protective element, or from any sparkover in the EUT, during and following the passage of test discharge current.

For semiconductors, the phenomenon appears related to conduction state of the EUT semiconductor devices at the time the ring wave occurs. Semiconductors parameters that might be involved include forward and reverse recovery characteristics and secondary breakdown performance.

The device most likely to fail in a phase-related way are semiconductors involved in the power input circuitry. Other devices, in different areas of the EUT, might also exhibit such failure modes in the EUT power-input circuits, if some or all of the transient pass through them.

- **Polarity reversal**

The sensitivity of semiconductors to the timing and polarity of a transient is one of the reason for selecting an oscillatory waveform to represent the environment; it will be more likely to provoke undue semiconductor failures than an unidirectional wave.

The breakdown of semiconductors under various conditions of load and transient overvoltages applications has been investigated.

The results below are related to the effect of transient polarity reversal on diode e.g. 1N679. The ring wave has been applied to the diode at the peak of the reverse voltage and the measured average breakdown voltage resulting being 1'800 V. The application of the ring wave at 30° and 90° after start of conduction has given a reduction of the average breakdown voltage of about 33% and 50% respectively.

The same investigation put in evidence that reverse voltage applied during the conduction period of the power frequency produces lower breakdown voltage than the application of the transient with no load or during blocking.

**1.1.3 Electric fast transient 5/50 ns**

Industrial measurement and control equipment practically always operates in conjunction with conventional control units (relays, contactors). Fluorescent lamp ballast units, insufficiently suppressed coffee grinders, vacuum cleaners, drilling machines, hair dryers, universal motors, etc. can be found everywhere in the power supply system. All these primarily inductive loads produce interference when switched on and off. A wide range of switching transients, also called bursts, are produced with the following waveform.

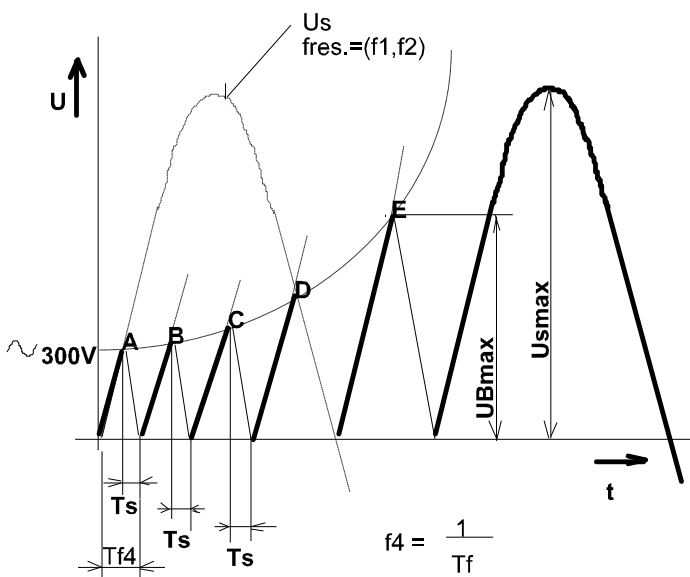

Figure: 1.0.3.1

The parameters which define the burst are:

- Rise time of the spike  $T_s$  in ns
- Repetition frequency  $f_4$  in the range of kHz up to MHz
- Energy, some mJ
- Voltage amplitude  $U_{Bmax}$ . up to some kV
- Duration of a burst several milliseconds

The different EFT sources generate different bursts waveforms. A typical waveform of a burst is shown in the next figure:

The impedance of the EFT source is generally high, therefore the capacitance of connected cables influences the rise time.

**1.1.4 Damped Oscillatory Wave 100 kHz or 1 MHz**

**Introduction:**

The damped oscillatory wave is a typical oscillatory transient, induced in low voltage supply of measuring cables due to the switching of three phase electrical networks in HV/N·MV open air station.

In electrical stations, the opening and closing operations of HV isolators give rise to sharp front-wave transients, with time of the order of some tens of nanoseconds. The voltage front-wave has an evolution that includes reflection, due to mismatching of the characteristic impedance of HV circuits involved. In this

respect, the resulting transient voltage and current in HV busbars are characterised by a fundamental oscillation frequency that depends on the length of the circuit and on the propagation time.

The oscillation frequency ranges from about 100 kHz to a few megahertz, depending on the influence of the parameter mentioned above and the length of the busbars, which may vary from some tens of meters to hundreds of meters. In this respect, the oscillation frequency of 1 MHz may be considered representative of most situations, but 100 kHz has been considered appropriate for large HV substations.

The repetition frequency is variable and a function of the distance between the switching contacts. The minimum repetition frequency in respect of each phase, is twice the power frequency. The repetition rates selected, 40/s and 400/s represent therefore a compromise, taking into account the different duration of the phenomena, the suitability of the different frequencies considered and the problem related to the energy to which the circuits under test are subjected.

**Impedance of the test generator**

For testing the input/output ports of measuring relays, the selection of the 200 Ohm impedance is a compromise. This takes into account that the characteristic impedance of cables used for this purpose (twisted pairs) has a value ranging from 120 to 150 Ohm in the frequency range above 100 kHz and for a length of the order of 100 m.

**Relevant standards:**

IEC 605-4, IEC 605-22-1, IEC 61000-4-18, IEC834-1, VDE 435 Teil 303, ANSI/IEEE C37.90.1

**Damped oscillatory wave  
Generator**

**Voltage at no load**

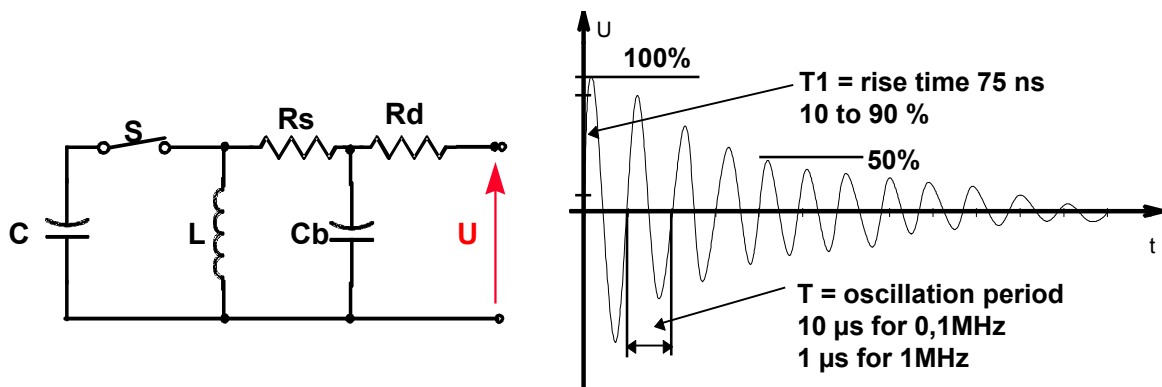

## 1.2 Impulse testers useably with CDN2000-06-25

### 1.2.1 MIG testers with 6 kV output voltage

#### **MIG0603 Combination Tester 6 kV and 3 kA without any coupling network**

The first two digit indicates the maximum output voltage of the tester and the next two digit the maximum output current.

#### **MIG0603IN**

Surge, Ring wave tester with single phase coupling decoupling network included. The CDN2000-06-25 can be used for three phase application with both waveforms up to 6 kV.

#### **MIG1203-CWG**

The MIG1203-CWG includes a a hybrid or combination circuit with a voltage wave shape 1,2/50  $\mu$ s and a current wave shape 8/20  $\mu$ s up to 6 kV.

#### **MIG0603-OS**

The MIG0603-OS includes a hybrid or combination circuit with a voltage wave shape 1,2/50  $\mu$ s and a current wave shape 8/20  $\mu$ s up to 6 kV. Additionally damped oscillatory wave circuits 1MHz and 100 kHz are included.

### 1.2.2 Impulse testers TRA

#### **TRA1000**

The SURGES and the Electric Fast Transients EFT can be superimposed on three phase power line with the CDN2000-06-25.

#### **Versions of TRA1000**

For all TRA versions with EFT or SURGE the CDN2000-06-25 can be used.

### 1.3 Technical data

#### 1.3.1 CDN2000-06-25

##### SURGE:

|                     |  |  |
|---------------------|--|--|
| <b>Coupling:</b>    | Connection between the impulse tester and the power supply line to the EUT.                    |  |
| Coupling path       | Manual selection of the coupling path on the front panel, coupling impedance see tester manual |  |
| IEC 61000-4-5       | L1-PE, L2-PE, L3-PE, N-PE  | 10 $\Omega$ 9 $\mu$ F plus 2 $\Omega$ within generator |
|                     | L1-L2, L2-L3, L1-L3, L1-N, L2-N, L3-N  | 2 $\Omega$ generator plus 18 $\mu$ F                   |
| Maximum Voltage     | 6'000 V  | Wave form 1,2/50 $\mu$ s                               |
| Damping             | corresponds to IEC 1000-4-5  | see test report  |
| <b>De-Coupling:</b> |  |  |
|                     | corresponds to IEC 1000-4-5  | see test report  |

##### EFT:

|                     |  |                                |
|---------------------|--|--------------------------------|
| <b>Coupling:</b>    | Connection between the impulse tester and the power supply line to the EUT.                    |                                |
| Coupling path       | Manual selection of the coupling path on the front panel, coupling impedance see tester manual |                                |
| IEC 61000-4-4       | L1-PE, L2-PE, L3-PE, N-PE<br>L1+L2+L3+N,to PE  | Tester 33 nF, filter 1 $\mu$ F |
| Maximum Voltage     | 4'400 V  | Wave form 5/50 ns              |
| Damping             | corresponds to IEC 61000-4-4   | see test report                |
| <b>De-Coupling:</b> |  |                                |
|                     | corresponds to IEC 61000-4-4   | see test report                |

##### Damped Oscillatory Wave

|                                |  |                           |
|--------------------------------|--|---------------------------|
| <b>Coupling:</b>               | Connection between the impulse tester and the power supply line to the EUT.                    |                           |
| Coupling path                  | Manual selection of the coupling path on the front panel, coupling impedance see tester manual |                           |
| IEC 61000-4-18 or IEC 60255-22 | differential mode  | Tester                    |
|                                | common mode  |                           |
| Maximum Voltage                | 3'300 V  | Wave form 1MHz or 100 kHz |
| Damping                        | corresponds to IEC 61000-4-18  | see test report           |
| <b>De-Coupling:</b>            |  |                           |
|                                | corresponds to IEC 61000-4-18  | see test report           |

**Ring Wave**

|                     |  |  |
|---------------------|--|--|
| <b>Coupling:</b>    | Connection between the impulse tester and the power supply line to the EUT.                    |  |
| Coupling path       | Manual selection of the coupling path on the front panel, coupling impedance see tester manual |  |
| IEC 61000-4-12      | L1-PE, L2-PE, L3-PE, N-PE<br>L1-L2, L2-L3, L1-L3, L1-N, L2-N, L3-N                             | Tester:<br>Z = 12 Ω - 10 μF<br>Z = 32 Ω - 3 μF |
| Maximum Voltage     | 6'000 V  | Wave form 0.5/100 kHz                          |
| Damping             | corresponds to IEC 61000-4-12  | see test report                                |
| <b>De-Coupling:</b> |  |  |
|                     | corresponds to IEC 61000-4-12  | see test report                                |

|                                |   |                                  |
|--------------------------------|---|----------------------------------|
| <b>Power supply EUT/ ac</b>    |   |                                  |
| Nominal voltage                | Phase - Phase                                 | 480 V +8% -15%                   |
|                                | Phase - Null                                  | 277 V +8% -15%                   |
|                                | Phase - Earth                                 | 277 V +8% -15%                   |
| Synchronisation                | onto different phases possible L1, L2 and L3. |                                  |
| Nominal current                | Continuous current:<br>pro Phase              | 25 A                             |
| Over current protection switch | Short time current:                           | 125 up to 250 A switching at <1s |

|                             |   |              |
|-----------------------------|---|--------------|
| <b>Power supply EUT/ dc</b> |   |              |
| Supply EUT/dc               | <b>with over current trip connected</b> |              |
| Supply voltage              | Phase to Phase<br>Phase to Null         | 115V<br>60V  |
| Nominal current             | L to L/N<br>L1//L2 to L3//N             | 25 A<br>50 A |
| Supply EUT/dc               | <b>with over current trip bypassed</b>  |              |
|                             | (d.c. supply input on the rear panel)   |              |
| Supply voltage              | Phase - Phase or Phase - Null           | 220V         |
| Nominal current             | L to L/N<br>L1//L2 to L3//N             | 25 A<br>50 A |



For interruption in accordance with IEC 61000-4-11 see technical data of the used generator.

1.3.2 Block diagram CDN2000

Original drawings see appendix of the manual

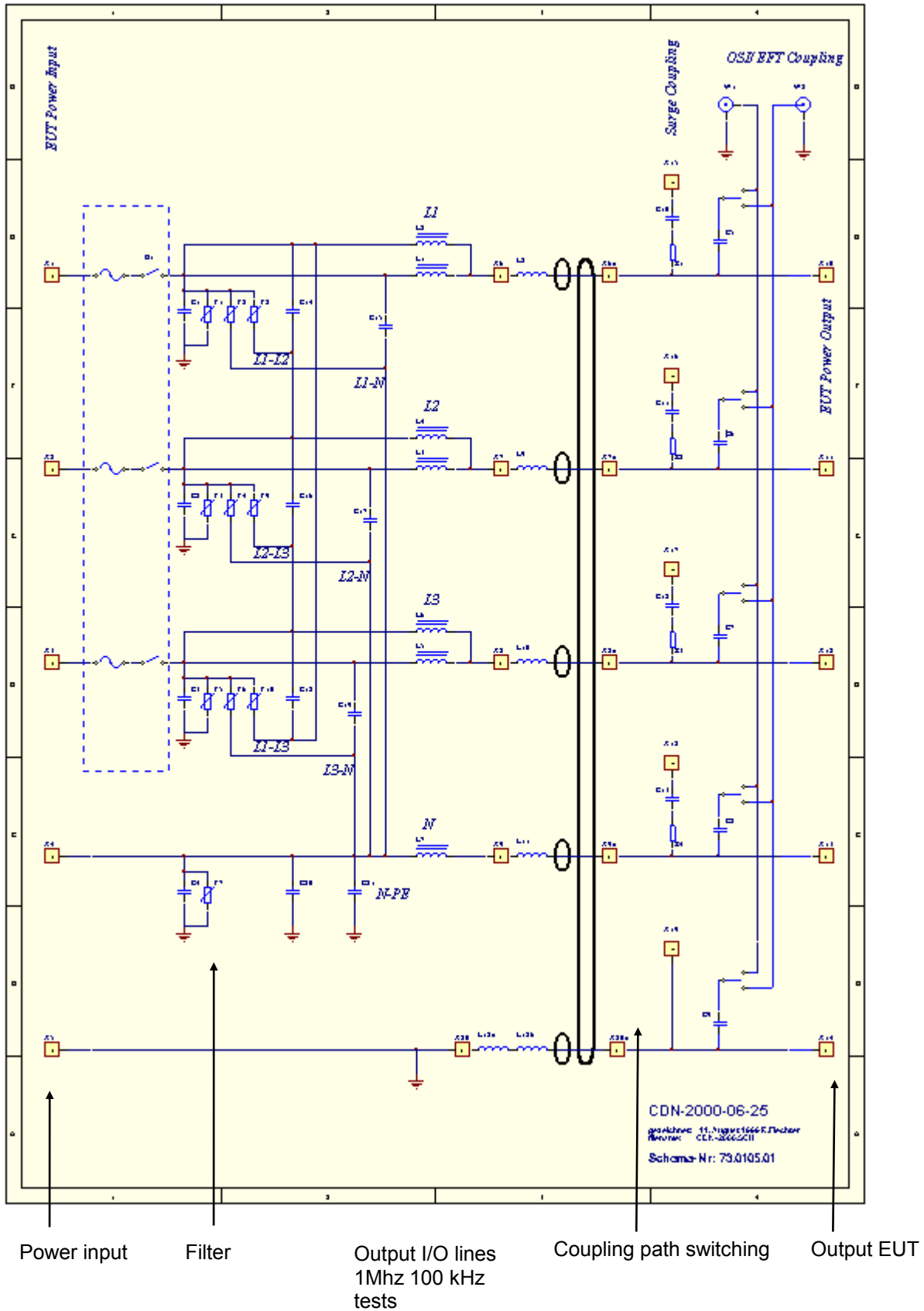

## 1.4 Mechanical dimensions

### 1.4.1 CDN2000-06-25 Tester

| Type          | Dimensions [mm]<br>l x w x h | Weight [kg] | Versions      |
|---------------|------------------------------|-------------|---------------|
|               | width x depth x height       |             |               |
| CDN2000-06-25 | 450 x 500 x 190              | 26          | 19" Rack 4 UH |

## 1.5 Power supply

No power supply is necessary.



## 1.6 Accessories delivered with the CDN2000-06-25

### 1.6.1 Included articles

CDN2000-06-25 (Article No. 103476)

#### Mechanical Dimensions

|              |       |
|--------------|-------|
| Unit Height: | 4     |
| Length:      | 57 cm |
| Width:       | 45 cm |
| Height:      | 19 cm |
| Net Weight:  | 29 kg |

#### Included Articles

According to STL-Variante 20, STL-Version 1

| Qty | PN     | Description   |
|-----|--------|---|
| 1   | 104801 | Brochure TRANSIENT 3000   |
| 1   | 104821 | Standard calibration report(s) for built-in EXT-TRA3000   |
| 1   | 103191 | Standard accessories pack   |
| 1   | 103194 | CD-UM-IN-ALL includes all User Manuals and Instruction sheets of all EMC PARTNER AG sales products. |

### 1.6.2 Standard accessories

Accessories to CDN2000-06-25 (Article No. 103476)

| Qty | PN     | Description  | Weight (kg) | Length (cm) | Width (cm) | Height (cm) |
|-----|--------|--|-------------|-------------|------------|-------------|
| 2   | 100261 | MC protected banana plug, yellow/green                               | 0           | 0           | 0          | 0           |
| 2   | 100279 | MC protected banana plug, blue                                       | 0           | 0           | 0          | 0           |
| 6   | 100281 | MC protected banana plug, black                                      | 0           | 0           | 0          | 0           |
| 8   | 100284 | MC bridge black  | 0           | 3.8         | 2.8        | 0.8         |
| 1   | 103027 | Accessory plastic pack   | 0           | 0           | 0          | 0           |
| 1   | 103063 | MC safety cable with protected banana plug, blue                     | 0           | 25          | 0          | 0           |
| 1   | 103065 | MC safety cable with protected banana plug, yellow/green             | 0           | 25          | 0          | 0           |
| 1   | 103070 | MC safety cable with protected banana plug, black                    | 0           | 50          | 0          | 0           |
| 1   | 103073 | MC safety cable with protected banana plug, blue                     | 0           | 200         | 0          | 0           |
| 1   | 103074 | MC safety cable with protected banana plug, yellow/green             | 0           | 200         | 0          | 0           |
| 3   | 103077 | MC safety cable with protected banana plug, black                    | 0           | 200         | 0          | 0           |
| 1   | 103078 | Coaxial cable 50 Ohm HV-BNC f/f                                      | 0           | 25          | 0          | 0           |
| 1   | 103084 | MC safety cable with protected banana plug, brown                    | 0           | 25          | 0          | 0           |
| 1   | 103085 | MC safety cable with protected banana plug, black                    | 0           | 100         | 0          | 0           |
| 1   | 103100 | MC safety cable with protected banana plug, white                    | 0           | 25          | 0          | 0           |
| 1   | 104366 | HV-BNC 50 Ohm cable, length 1m to connect Generator with accessories | 0           | 100         | 0          | 0           |
| 1   | 104516 | Galvanized copper plate  | 0           | 14          | 3          | 0           |



## 2 Safety

The CDN2000-06-25 belongs to safety class 1

### 2.1 Safety standards

The CDN2000-06-25 fulfils the requirements of the safety standards IEC 1010 „Safety requirements for electrical equipment for measurement, control and laboratory use and the safety standard VDE 0104 ( Safety circuits, warning lamps or connector for warning lamps ). Based on EN 61010 (IEC 1010) the declaration of conformity to low voltage directive LVD 73/23/EEC (O.J. N° L77, 1973-03-26) is given.

**This manual is a integral part of the CDN2000-06-25. The instructions contained in the manual regarding operation and the test set up are to be strictly observed.**

### 2.2 Climatic Conditions

The CDN2000-06-25 contain high voltage circuits in integrated form. EMC PARTNER only guarantees a correct functioning of the CDN2000-06-25 and the associated accessories, if the CDN2000-06-25 is operated in the climatic condition specified.

|                      |   |                    |
|----------------------|---|--------------------|
| Temperature          | 15 °C to 35 °C  |                    |
| Relative humidity    | 45 % to 75 %  |                    |
| Atmospheric pressure | 86 kPa to 106 kPa   | (860 to 1060 mbar) |
| Not influenced by:   | direct solar radiation, rain or condensate water, dust or larger electro magnetic fields as specified in the EMC compatibility chapter. |                    |

Tab. 2.2

The CDN2000-06-25 should be operated in a dry, clean room. If for any reason water condenses in the CDN2000-06-25, then no CDN2000-06-25 operation should be started before the unit is dry.

**It is strictly forbidden to operate the CDN2000-06-25 generators in rooms with of gas explosion risk. The high voltage of the CDN2000-06-25 can generate sparks, which can ignite the gas.**



**People with heart pacemakers should not be in the vicinity of the test set up during operation.**

### 2.3 Precautionary measure during use

The energy content of the SURGE impulse is high and can be dangerous with improper use. It is wise to observe the following rules:

|   |
|---|
| • Never touch the EUT when a test is in operation.  |
| • Touch no connectors of connection cable when a EMC test is in operation.  |
| • The high voltage of the CDN2000-06-25 and the power on the EUT must turned off before a manipulation on the EUT is carried out. |
| • For all services, e.g. check of the fuses, the power cord must first be unplugged.  |

Tab. 2.3

The CDN2000-06-25 must be connected to power line with a safety ground. Connect always first the protective earth and neutral before the phases.

### 2.4 Electromagnetic Compatibility

The CDN2000-06-25 fulfils the following immunity requirements:

|                           |                |                |
|---------------------------|----------------|----------------|
| • Electrostatic discharge | Level 4 (8 kV) | (IEC 1000-4-2) |
| • Burst EFT               | Level 4 (4 kV) | (IEC 1000-4-4) |
| • SURGE                   | Level 3 (2 kV) | (IEC 1000-4-5) |



### 2.5 The manual is an integral part of the equipment. Refer to the manual.

|  |
|--|
| <p><b>This manual is an integral part of the CDN2000-06-25. The safety rules and precautions in the manual must be observed. EMC PARTNER and their representatives are not responsible for damage to persons and equipment by not observance the safety rules and precautions in the manual.</b></p> |
|--|

### 3 Mechanical Structure

#### 3.1 General

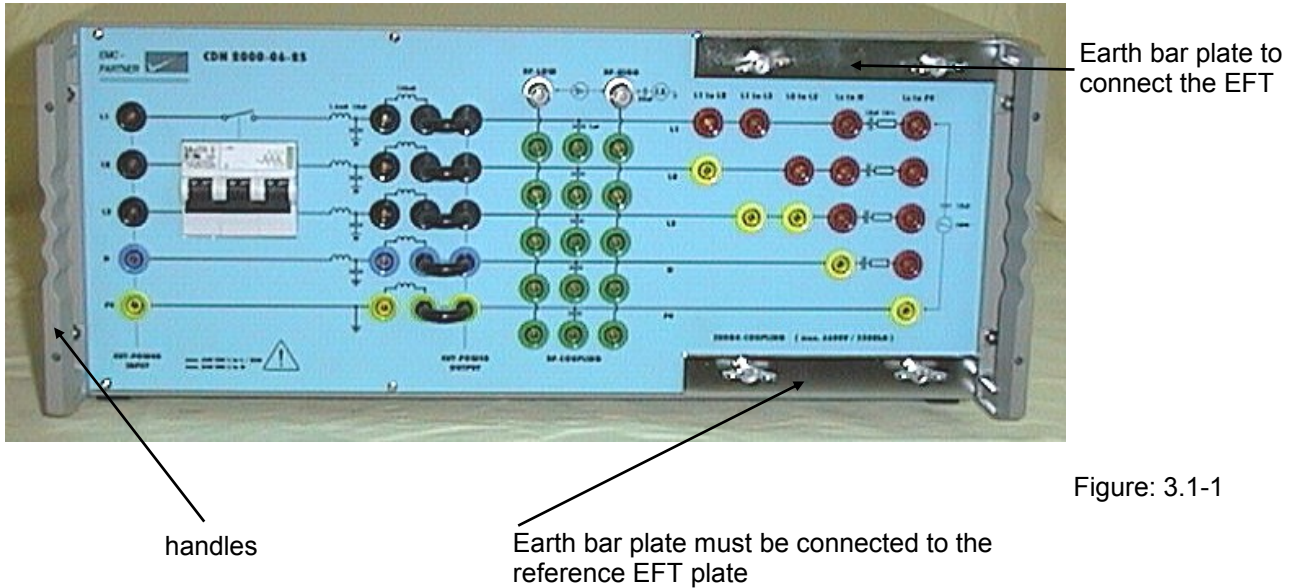

Figure: 3.1-1

During continuous operation of the three-phase coupling network with a current of 25 A per phase, the housing of the coupling network can become warm.

The following connection cables are supplied with the three-phase coupling network:

#### **Mains feed and Test Object connection**

3 black banana plug cables, length 2 m (for the three phases)

1 blue banana plug cable, length 2 m (for the neutral)

1 green/yellow banana plug cable, length 2 m (for the protective earth connection)

These 5 cables are to be cut in the middle. One half of the cables must be fitted with a mains plug corresponding to the public mains connection. The other half is to be connected to the test object.



#### **Caution!**

Only the delivered cable and accessories are allowed to use with the CDN-2000! The weight of the filter is 28 kg.



## 4 Panels of the CDN2000-06-25

### 4.1 Front panel of the CDN2000-06-25

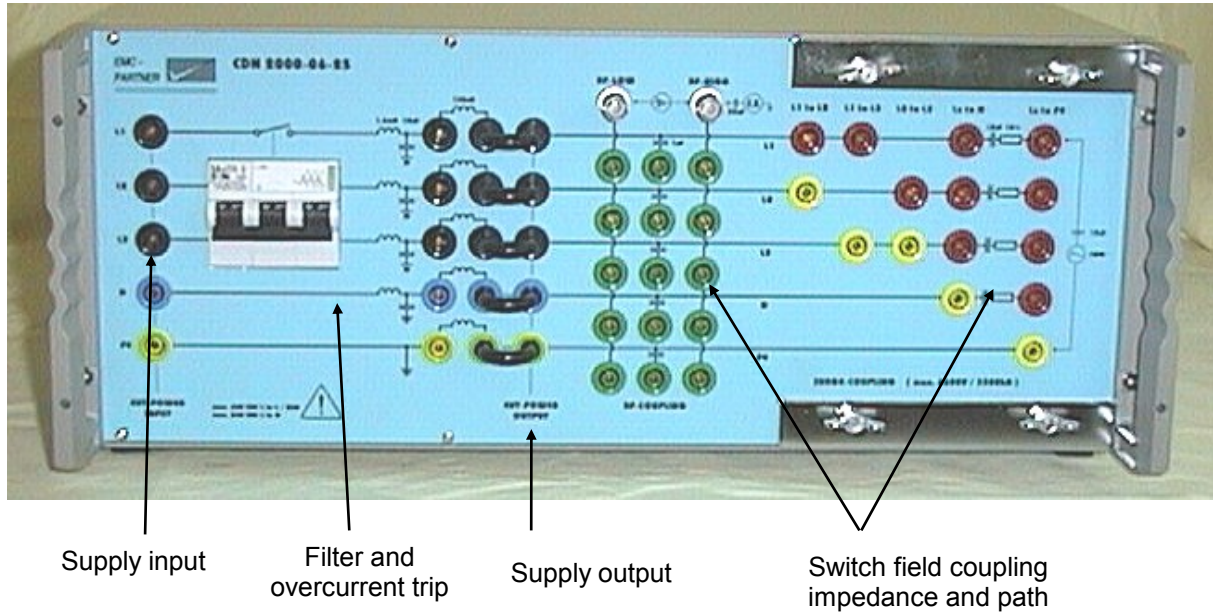

For fusing, a combined circuit breaker is built in. The trip point lies slightly above the nominal current level and therefore only causes a separation by a moderate continuous overload. The magnetic trips are set for a switching point at 5 to 10 times the nominal current, so that they do not inadvertently react to the high start-up currents of motors or to current peaks from transformers.

The SURGE coupling is clearly organised as shown in the above photograph. For couplings between the phases or phase and neutral, 18  $\mu\text{F}$  is switched in as a coupling element. For couplings against the protective earth, the coupling impedance changes to 10 Ohm with 9  $\mu\text{F}$  in series.





## 5 Preparation for Operation

### 5.1 Attention, Refer to Manual

**This manual is an integral part of the equipment CDN2000-06-25. The safety rules and precautions in the manual must be observed. EMC PARTNER and their representatives accept no responsibility not responsible for damages to persons and equipment as a results of non-observation of the safety rules and precautions in this manual.**

Before connecting the CDN2000-06-25 to a public power line, Chapter 3 „Safety must be carefully studied.

### 5.2 Operators and Service Personnel

Only trained personnel should carry out EMC tests. EMC PARTNER recommends its own seminars. For small groups of maximum 10 persons EMC PARTNER AG offers the following in-house seminars in English or German at the customer's location:

1. EMV Introduction
2. EMV Standardisation
3. EMC „ESD“ immunity test
4. EMC „EFT“ immunity test
5. EMC „SURGE“ immunity test
6. EMC „DIPS“ immunity test
7. EMC „HARMONICS“ immunity test
8. EMC „MAGNETIC FIELD“ immunity test
9. EMC „CW CURRENT INJECTION“ immunity test
10. EMC „CE-MARK“ transient immunity tests
11. „NEMP“ immunity test
12. „AC, DC, IMPULSE“ insulation test
13. Flicker

### 5.3 Checks before operation

#### 5.3.1 Optical verification of the CDN2000-06-25

Before you unpack the CDN2000-06-25, please check whether the packing is deformed or damaged. When the CDN2000-06-25 is unpacked, also check whether the tester is damaged. If you detect a damage, please inform EMC PARTNER and the shipping organisation immediately.



Figure: 5.3.1-1

Please keep the shipping box on stock. The must be used in case of shipment for verification or repair.

5.3.2 EUT Power, Power source for the EUT

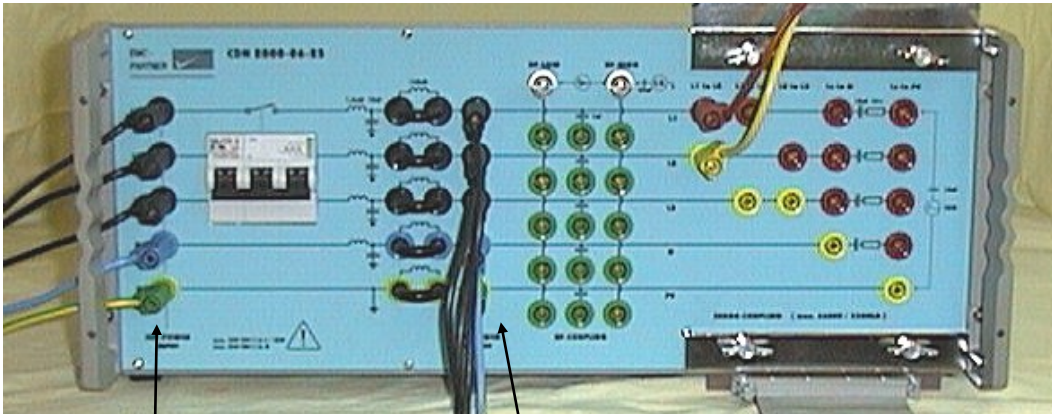

Power Supply input

Power Supply EUT

To connect the EUT Power Input with the public power supply please cut the three black, blue and green/yellow cables supplied into two halves of the same length. One half used for the EUT Power connection to the CDN2000-06-25, and the other half for supplying the EUT.

5.3.3 I/O lines coupling

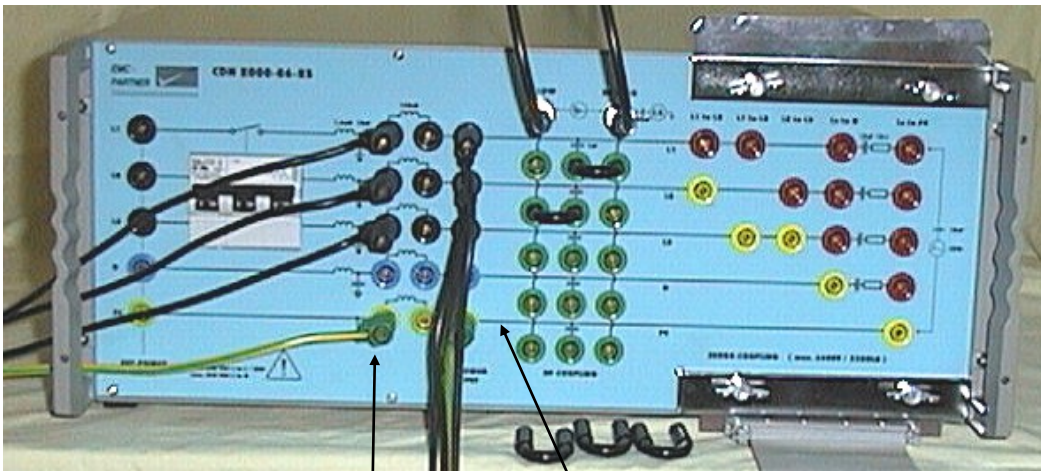

I/O lines input

to EUT

The CDN2000 can be used for EFT or Damped oscillatory Wave coupling in I/O lines. The input of the I/O lines must be connected to the 140  $\mu$ H inductance. In this test set up the 1.6 mH inductance will be bypassed.

This arrangement can be use to set up the required four lines coupling specified in IEC 255-22.

### 5.3.4 SURGE coupling set up

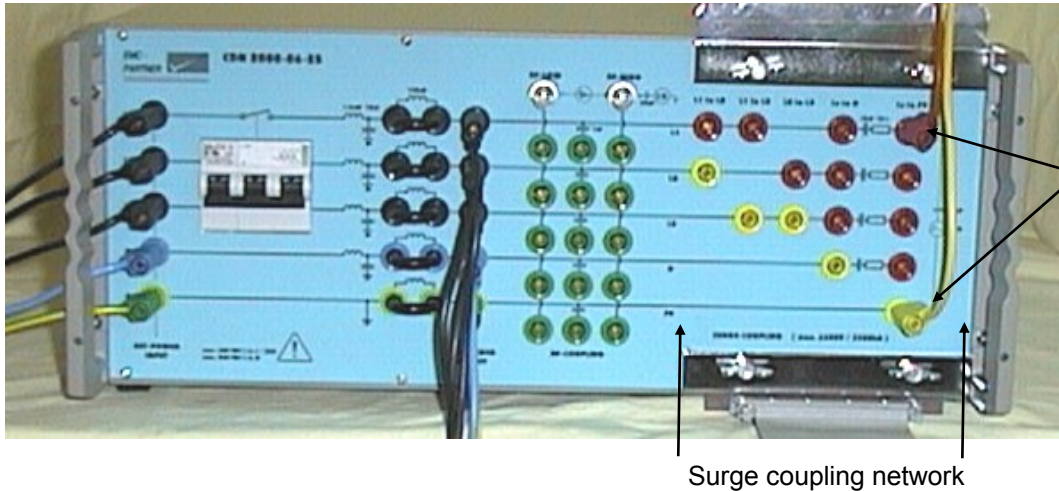

Surge coupling  
L to PE  
The CWG part  
of MIG or TRA  
are equipped  
with 18  $\mu$ F

Surge coupling network

The SURGE coupling is clearly organised as shown in the above photograph. For couplings between the phases or phase and neutral, 18  $\mu$ F is switched in as a coupling element. For couplings against the protective earth, the coupling impedance changes to 10 Ohm with 9  $\mu$ F in series.

The colours of the cables and their plugs, as well as the colours of the sockets of the TRANSIENT 1000 or MIG testers and of the CDN-1000 coupling network should agree. The yellow cable should be used for "low" and the red cable for "high".

The desired coupling must be plugged onto the three-phase coupling network.

To synchronise the SURGE onto one of the phase L1 to L3 the Surged phase must be connected to the TRANSIENT-1000 rear side EUT-power 1. Use the black banana cable length 1 m. The neutral and the protective earth must be connected on the rear side of the testers and the CDN2000 (colour blue and yellow green).

The EFT coupling cable (high-voltage BNC) can remain plugged in during the SURGE test.

#### Caution!

The position of the short circuit bridge must be as showed in the figure above.

### 5.3.5 Ring Wave coupling set up

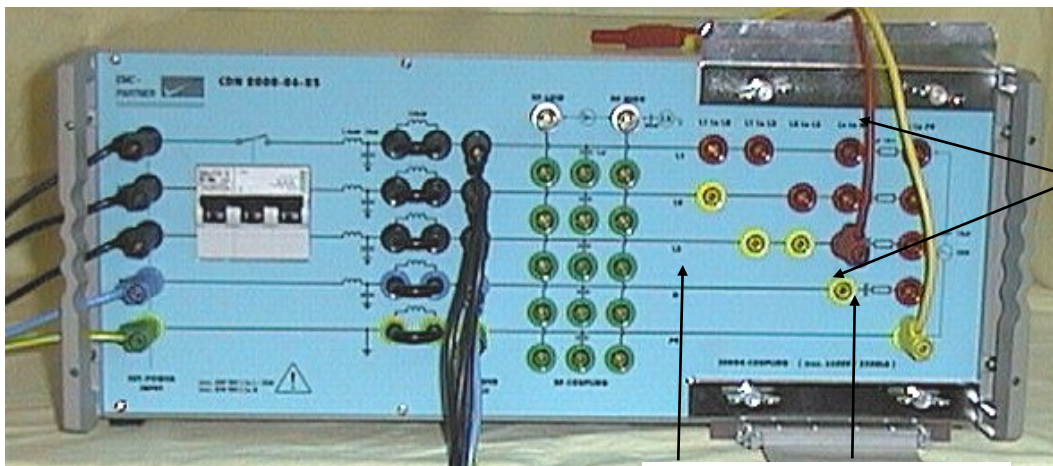

The Ring  
Wave part of  
MIG is  
equipped with  
10  $\mu$ F for 12  $\Omega$   
3  $\mu$ F for 32  $\Omega$

Ring Wave coupling network

**CDN2000-06-25 coupling decoupling network**

The Ring Wave coupling is clearly organised as shown in the above photograph. All coupling path are equal as for the SURGe coupling except the coupling to protective earth. The coupling L to PE must be made as showed in the figure above (no additional resistor or capacitor in circuit).

The colours of the cables and their plugs, as well as the colours of the sockets of the MIG0603IN tester and of the CDN-1000 coupling network should agree. The yellow cable should be used for "low" and the red cable for "high".

The desired coupling must be plugged onto the three-phase coupling network.

To synchronise the Ring Wave onto one of the phase L1 to L3 the surged phase must be connected to the MIG0603IN rear side EUT-power . Use the black banana cable length 1 m. The neutral and the protective earth must be connected on the rear side of the testers and the CDN2000 (colour blue and yellow green).

The EFT coupling cable (high-voltage BNC) can remain plugged in during the SURGE test

**Caution!**

The position of the short circuit bridge must be as showed in the figure above.

**5.3.6 EFT coupling set up**

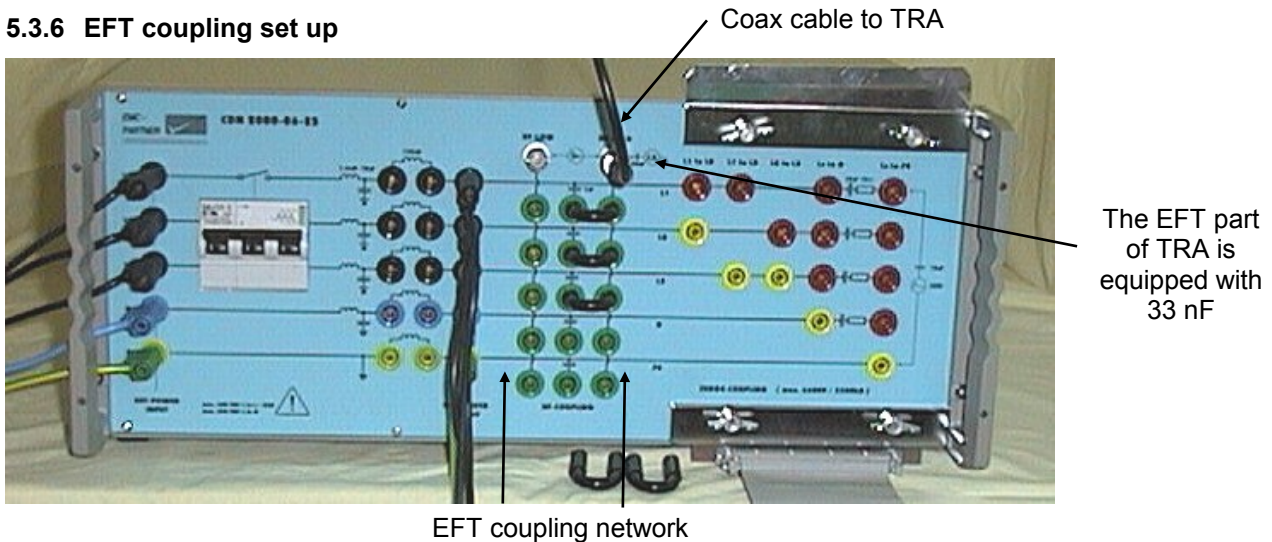

EFT coupling network

The EFT pulses are generally coupled in between the lines and the reference plate. Individual couplings between the lines are not meaningful, as the EFT pulse is already coupled into all parallel lines for line lengths of around 1m, via the coupling capacitance between the lines.

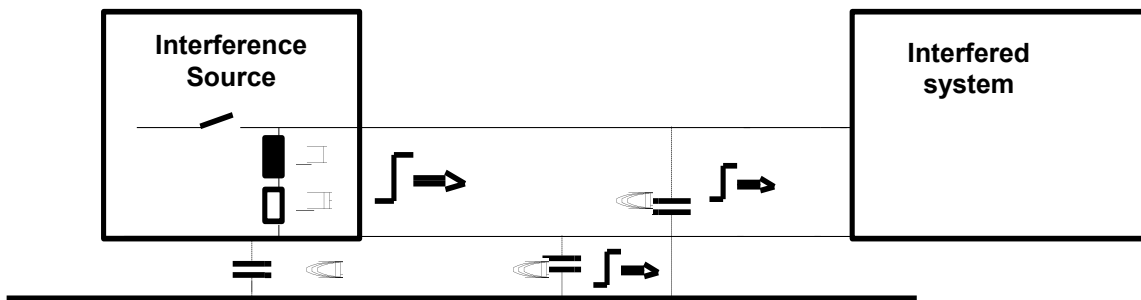

The test time can also be shortened considerably. In the new EFT Modification Paper, only this coupling is recommended.

Select the high-voltage output in the "Main" menu of the TRANSIENT 2000.

**Caution!** To avoid reflections, the SURGE coupling lines (yellow and red cables) must always be unplugged during the EFT test.

To synchronise the EFT onto one of the phase L1 to L3 the surged phase must be connected to the TRA2000 rear side EUT-power . Use the black banana cable length 1 m. The neutral and the protective earth must be connected on the rear side of the testers and the CDN2000-06-25 (colour blue and yellow green).

The desired coupling must be plugged with the MC bridge. Not used bridges must be placed in front of the CDN2000-06-25 as showed in the figure above. The figure above shows the coupling L1+L2+L3 to reference ground plane of the test set up.

### 5.3.7 Damped oscillatory coupling set up

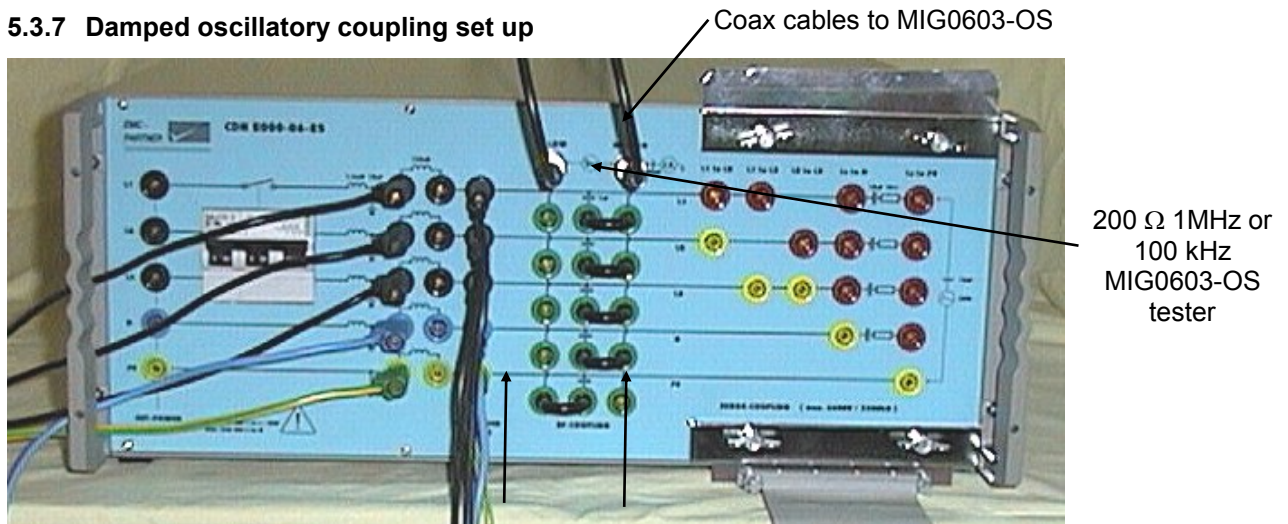

Damped Oscillatory Wave coupling network

The damped oscillatory pulses can be coupled either in common or differential mode. For differential mode the tester must have a earth potential free design (two HV outputs).

**Caution!** To avoid reflections, the SURGE coupling lines (yellow and red cables) must always be unplugged during the EFT test.

The desired coupling must be plugged with the MC bridge. Not used bridges must be placed in front of the CDN2000 as showed in the figure above. The figure above shows the coupling L1+L2+L3+L4 to PE. The coupling capacitance per path will be 0.5  $\mu$ F.



## 6 Testing with the CDN2000-06-25

### 6.1 Quickstart of TRA or MIG together with CDN2000-06-25

For MIG operation refer to the MIG manual and for TRA operation refer to TRA manual section "Quickstart".

- All connection must be made as described in chapter 5 at the rear and the front panel of the CDN.

#### 6.1.1 MIG0603Inx Operation with CDN2000-06-25

- Before starting a test, the generator must be configured as follows:

```

Main 1                               CWG 1.2/50u 2ohm
U-peak : 2000V                       U-CRO: 1V= 600V
Polarity : pos                       I-CRO: 1V= 300A
Number of Pulses: 20                 Syncro Deg: 0°
                                      Repetition: 10s
SETUP  SHAPE  MAIN  RAMP  Menu  More
  
```

Select test voltage  
Select number of pulses = total number of pulses for ALL coupling paths.

```

Main 2                               CWG 1.2/50u 2ohm
Coupling Surge to Port: CDN-3phase
L1+L2:off L1+N:off L1+PE:off N+PE:off
L1+L3:off L2+N:off L2+PE:off L123+
L2+L3:off L3+N:off L3+PE:off N+PE:off
SETUP  SHAPE  MAIN  RAMP  Menu  More
  
```

Select CDN-3phase from the menu.  
The coupling path is not relevant, as switching must be undertaken manually by the operator on the CDN2000-06-25 front panel

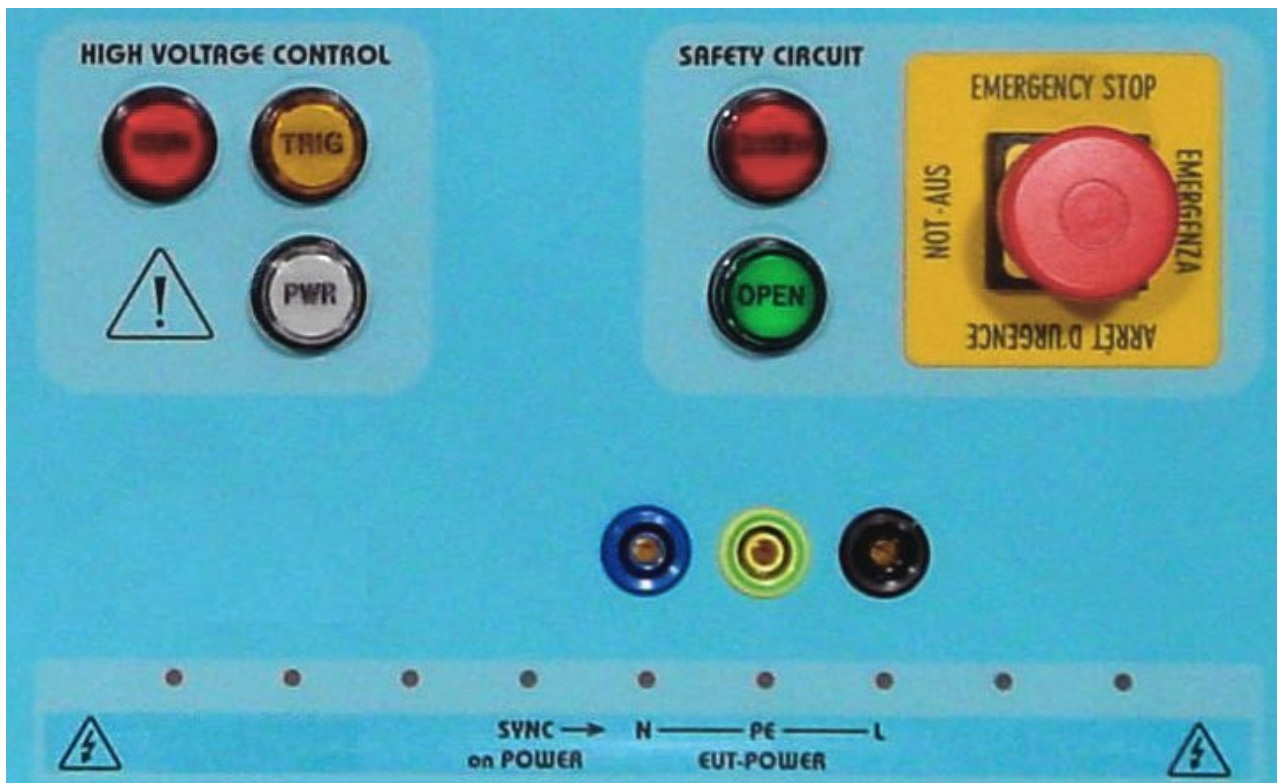

Ensure the PWR button is NOT enabled (light extinguished).

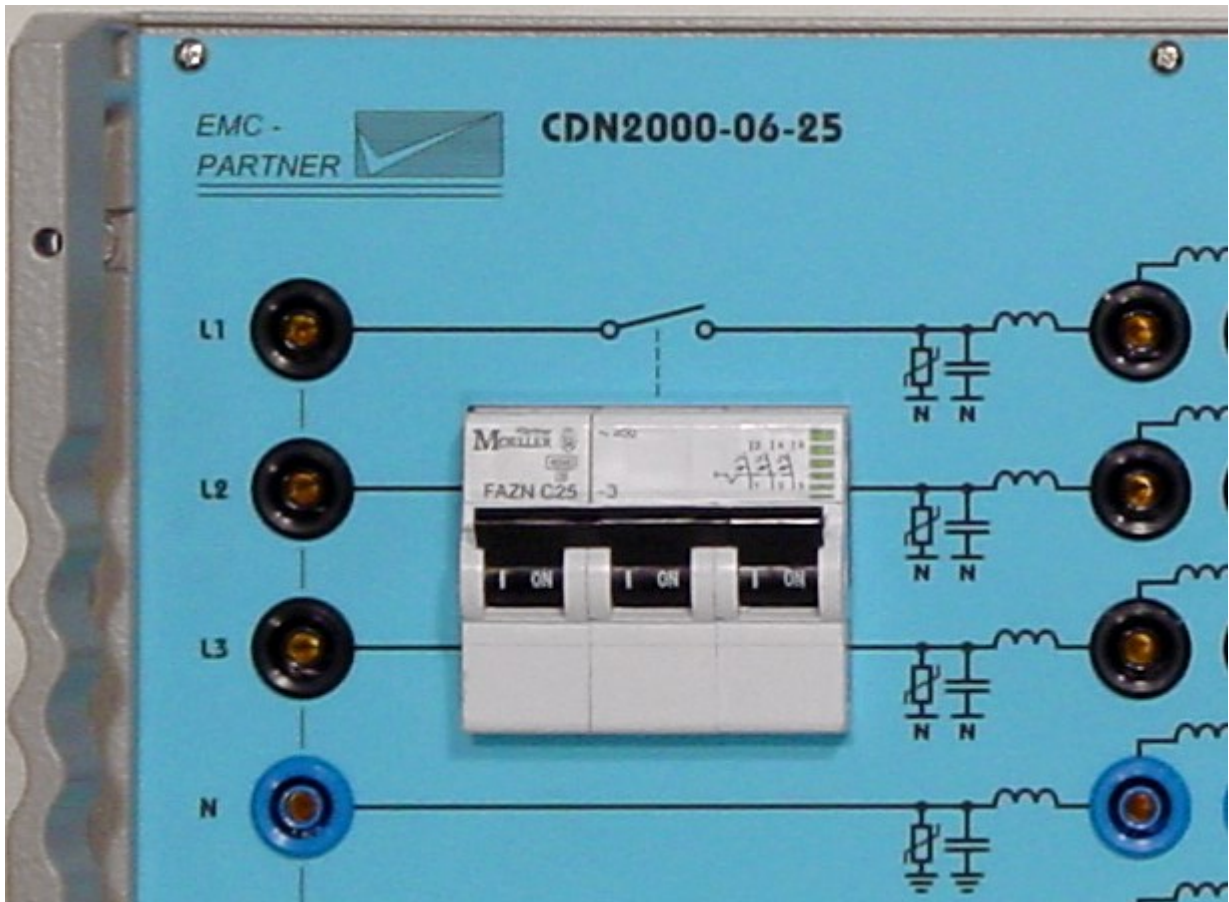

- The supply power of the EUT should be switched on with the magnetic over current switch as shown above.



## 7 Maintenance and Servicing

### 7.1 Maintenance

No further maintenance is necessary on the CDN2000-06-25.

### 7.2 Verification of the CDN2000-06-25 by the user

A simple verification whether high voltage pulses occur at the tester outputs can be carried out using an oscilloscope of a bandwidth of 20 MHz.

#### 7.2.1 Combination Wave Tester



#### **Caution!**

Before the verifications are started remove the connection EUT power input to public power supply.

Verification as specified in the Basic Standard 1000-4-5.

- Measurement of output voltage at no load
- Measurement of short circuit current with short circuit output
- Check that voltage and current waveform are within the tolerances.
- Calculate the source impedance from the peak voltage divided by the peak current.

#### **1. Setting „Main Menu“**

V = 2000 V; Repetition 10s

#### **2. Measuring point:**

SURGE U-CRO for the voltage measurement at no load

SURGE I-CRO for current measurement at short circuit (make a short circuit on the EUT power output phase to neutral on the front panel of the CDN2000-06-25 generator)

#### **3. Settings at the oscilloscope**

Time base 5  $\mu$ s,

Vertical deflection 0.5 V / Division

Definition of the wave forms and their tolerances see chapter Insulation

### 7.2.2 Ring Wave Tester

**1. Settings „Main Menu“**

V = 2000 V; Repetition 10 s

**2. Measuring point:**

SURGE U-CRO for the voltage measurement at no load

SURGE I-CRO for current measurement at short circuit (make a short circuit on the EUT power output phase to neutral on the front panel of the CDN2000-06-25)

**3. Setting of the oscilloscope**

Time base 200  $\mu$ s,

Vertical deflection 0.5 V / Division

Definition of the wave forms and their tolerances see chapter energy

### 7.3 Verification of the CDN2000-06-25 at EMC PARTNER

EMC PARTNER verify the CDN2000-06-25 in accordance with IEC 61000-4-5 standard.

Before a CDN2000-06-25 is delivered, all verifications are carried out in accordance with the basic documents.

See separate test report of CDN2000-06-25 attached to this manual, or delivered with the CDN.

## 8 What must be done following failed operation

### 8.1 Service; Repairs

The CDN2000-06-25 is a compact equipment and servicing or repairing the tester can only be carried out by EMC PARTNER authorised service companies.

### 8.2 Spare parts list

No spare parts are necessary for the MIG.

### 8.3 Hints when varistors have been damaged in a CDN

#### 8.3.1 General

- 1) For correct and repeatable test results the CDN input potentially must be fixed (varistors and filters) as shown in the drawing attached.
- 2) The varistor can not be destroyed by a SURGE. The energy of the SURGE generator into the varistor is limited by the generator, coupling impedance and the decoupling coils 1.8mH
- 3) The varistor can only be destroyed by too high power line voltage and continuous a.c. current passing the varistors. Below are the reasons listed, why too high power line voltages can occur across the varistors:
  - a) Too high voltage at the input of the CDN e.g. instead of 440V a 690V is connected at the CDN input
  - b) N is not connected to PE. Continuous voltage > 300V caused by unsymmetrical loads will destroy varistors between N to PE
  - c) Unbalanced voltages caused by heavy unsymmetrical EUT loads e.g. 1 phase short circuited, generate > 300V L to N
  - d) Unbalanced power supply caused by heavy load equipment (e.g. short circuit on one phase) on same power supply as the CDN
- 4) Over 250 CDN from EMCP working fine without any problem over many years.

#### 8.3.2 What can be done after varistors has been destroyed?

When a problem with a standard 480V CDN occurs, please check the following:

- 1) Measure with a multimeter the power supply voltages (CDN not connected)
  - a) Lx to L  $\leq 480V \text{ rms} + 8\%$
  - b) Lx to N  $\leq 480V / 1.732 \leq 277V \text{ rms} + 8\%$
  - c) L to PE  $\leq 480V / 1.732 \leq 277 \text{ V rms} + 8\%$
  - d) N to PE = 0V
- 2) When N to PE shows some volts make a connection between N and PE and either measure the current in the cable or check whether the cable get warm
- 3) When the cable is cold (no current) make a connection N to PE at the CDN input with 4 mm banana plugged cable
- 4) Replace the varistors. Varistors sets can be ordered from EMCP reps.
- 5) For correct test set-up see user manual of the used CDN
- 6) Connect always first the PE, second N, last the L
- 7) For further analysis please send the following information to EMCP PARTNER: Generator setting and test sequence any load information.

More information can be found in the attached drawing page 2 and in the user manual

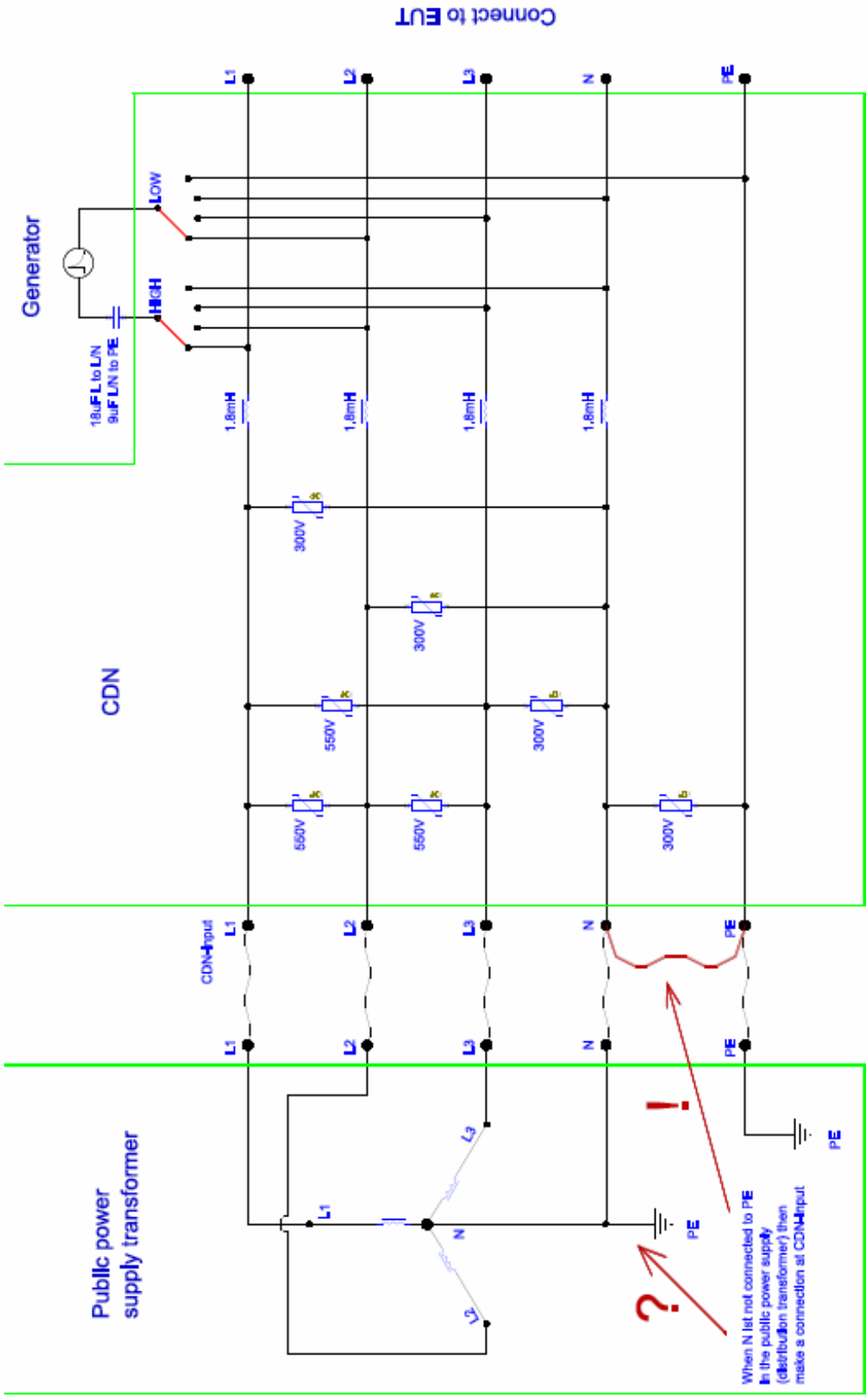

|  |  |                          |              |
|--|--|--------------------------|--------------|
|  |  | Description: EMC-Partner |              |
|  |  | Date: 10.10.2008         | Version: 1.0 |
| Title: Connection to public power supply |  | Part No: 70.1230.01      |              |
| Author:                                  |  | Date:                    |              |
| Checked:                                 |  | Date:                    |              |
| Approved:                                |  | Date:                    |              |

## 8.4 Service department of EMC PARTNER AG

EMC PARTNER AG  
Baselstrasse 160  
CH - 4242 Laufen  
Switzerland  
Tel. ++41 61 775 20 50  
Fax ++41 61 775 20 59  
Email [service@emc-partner.ch](mailto:service@emc-partner.ch)  
Web [www.emc-partner.com](http://www.emc-partner.com)

## 8.5 Information for dismantling

There is no danger involved in dismantling the CDN2000-06-25.

## 8.6 Parts which can be recycled

The CDN2000-06-25 contains parts made from steel, aluminium, PVC, two-component sealing compound. The impulse capacitors are filled with non-poisonous mineral oil. The various parts can be separated and recycled.

## 8.7 Parts which can not be recycled

All parts in the CDN2000-06-25 can be recycled



## 9 Recycling / Disposal

### 9.1 RoHS directive 2002/95/EG

The CDN2000-06-25 complies with the directive 2002/95/EG (RoHS - Restriction of certain Hazardous Substances).

From December 2005, all EMC Partner products either hand soldered or by machine are produced using lead-free solder.

### 9.2 WEEE directive 2002/96/EG

The EMC Partner CDN2000-06-25, is exempted from the directive 2002/96/EG (WEEE) under category 9.

The product should be recycled through a professional organisation with appropriate experience for the disposal and recycling of electronic products. EMC Partner are also available to help with questions relating to the recycling of this product.

### 9.3 Information for dismantling



Remove always power cord fist.

There is no special danger involved in dismantling the CDN2000-06-25.

### 9.4 Parts which can be recycled

The CDN2000-06-25 contains parts made from steel, aluminium, PVC, two-component sealing compound. The impulse capacitors are filled with non-poisonous mineral oil. The various parts can be separated and recycled.

### 9.5 Parts which can not be recycled

All parts in the CDN2000-06-25 can be recycled.





## 10 Appendix and Correction

### 10.1 Appendix

#### 10.1.1 Verification of the 1,2/50; 8/20 $\mu$ s waveform

See chapter clamping voltage tests 8/20  $\mu$

#### CWG Combination Wave Generator

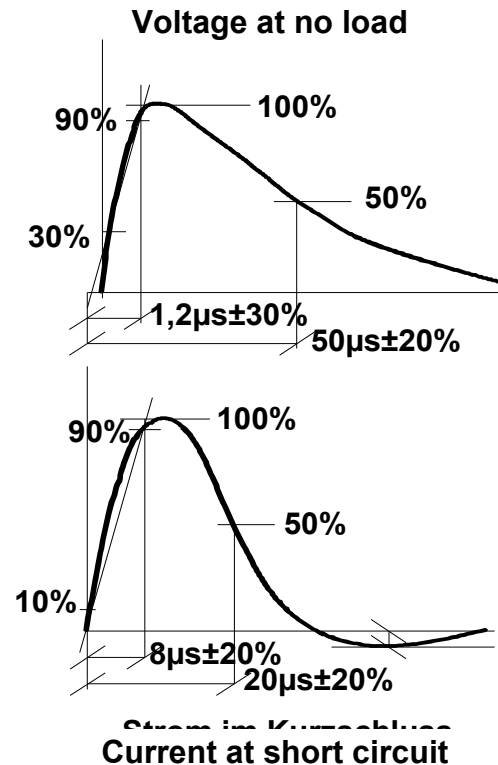
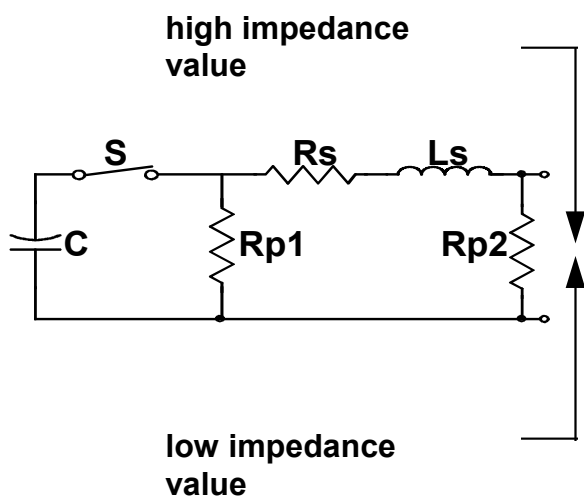

With this information the SURGE circuit of the MIG can be easily

Example: "Voltage"

- choose 1 kV charging voltage
- measure the no load voltage at the generator output. Check whether the wave-form is within the tolerances or not.

Surge voltage front time  $T_1 = 1.2 \mu s \pm 30\%$

0.84 - 1.56  $\mu s$

Time to half value  $T_2 = 50 \mu s \pm 20\%$

40 - 60  $\mu s$

measure  $U_{max}$ .

Example "Current"

- choose 1 kV charging voltage
- measure the short circuit current at the generator output. Check whether the wave-form is within the tolerances or not.

Surge current front time  $T_1 = 8 \mu s \pm 20\%$

6.4 - 9.6  $\mu s$

Time to half value  $T_2 = 20 \mu s \pm 20\%$

16 - 22  $\mu s$

measure  $I_{max}$

Check the source impedance:

$U_{max} / I_{max} = 2 \text{ Ohm} \pm 10\%$

## 10.2 Correction

### 10.2.1 TRA2000 with CDN2000 SURGE Synchronisation

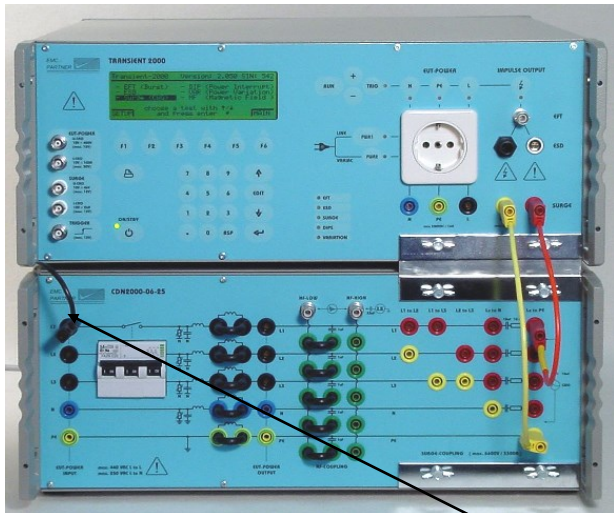

Different possibilities exist to Synchronize the TRA-generator with a three phase coupling filter.

Example: The SURGE impulse must be synchronized with the phase L1 to PE.

Set the black banana plugged cable for Synchronization and the yellow and red cable for the surge pulse as showed in the pictures beside.

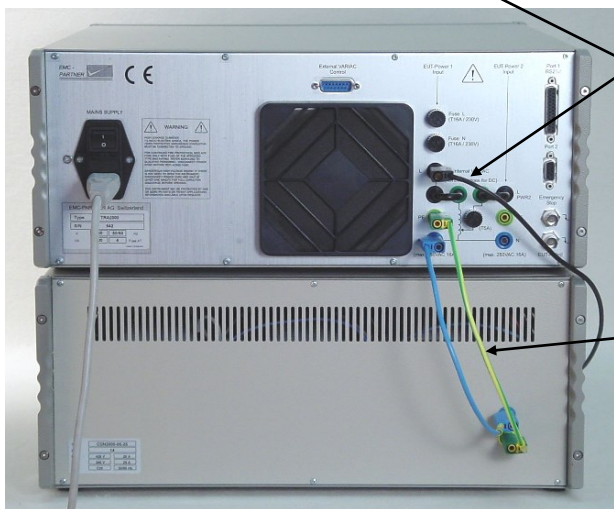

Cable for the synchronisation. Please use the 1 m black cable delivered with the CDN2000 to synchronize the TRA2000 with the desired phase of the CDN2000.

In the pictures the synchronisation is made for the Phase L1.

Additionally the neutral and the protective earth must be connected on the rear side of between the TRA2000 and the CDN2000

```

Surge Main 3      Power: 0V 0.0A
TRIGGER
Trigger Mode : auto
Power Syncro : on
Peak Syncro : off
Syncro: 90° at positiv, 270° at negativ

Surge Main 1      Power: 0V 0.0A
U-peak : 1000V
Polarity : pos
Waveform : CWG
Number of Pulses : 10
Syncro Deg: 90°
Repetition: 5s
    
```

First the Peak Synchro must be turned „OFF“

When the Peak Synchro is turned „OFF“ in the Display SURGE Main 1 the synchronisation angle can be selected.

Depending on the SURGE coupling (cable yellow and red) the synchronisation angle must be set as defined below:

Coupling: **Phases to PE or N** and Synchronisation (black cable on L1)

- SURGE L1: 0° equal 0°
- SURGE L2: 0° equal 120°
- SURGE L3: 0° equal 240°

Note: The 0° is defined as the angle at which the Surge is superimposed on the power supply depending of the manually selected red yellow connections.

Coupling: **Phases to Phases** and Synchronisation (black cable on L1)



- SURGE L1 to L2: 0° equal 330°
- SURGE L2 to L3: 0° equal 90°
- SURGE L1 to L3: 0° equal 210°

## 11 Glossary

Wherever possible, IEC 50 (IEV 161) terms are used.

|   |   |
|---|---|
| EUT   | Equipment under Test  |
|   | English abbreviation for the test object  |
| EST   | French abbreviation for the test object   |
| EMV = EMC = CEM                                 | Electro Magnetic Compatibility Elektromagnetische Verträglichkeit   |
| Hybrid puls                                     | Voltage at open circuit and current at short circuit 8 / 20 $\mu$ s.  |
| CWG   | Term used in IEC-100-4-5 for Surge Tester Combination Wave Generator  |
| Coupling network k                              | Electrical circuit with which energy can be transferred from one circuit to another, with as little loss as possible. |
| Decoupling network                              | Electrical circuit with which the transfer of energy from one circuit to another is prevented                         |
| Superimposed network<br>(single or three-phase) | Consist of a decoupling network and a coupling network for single or three phase applications.                        |
| EFT   | Electric Fast Transient<br>Switched inductance  |
| ESD   | Electric Static Discharge<br>Discharge of static energy   |
| SURGE   | High energy interference impulse<br>such as can arise in networks as a result of lightning or switching               |
| DIP   | Short-term mains failure or loss of voltage   |
| IEC   | International Standardisation for Electro-technology  |
| VARIAC  | Adjustable auto-transformer   |
| SPIKE   | A pulse during an EFT or Burst package  |
| CRO   | Cathode-Ray Oscilloscope  |
| HV  | High voltage  |
| rms   | Root-mean square (effective) value  |
|   |   |
|   |   |
|   |   |

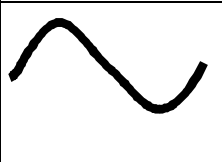
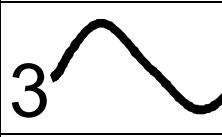
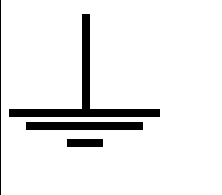
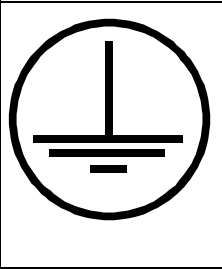
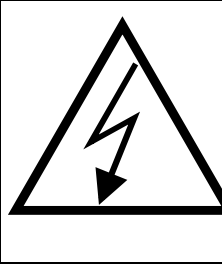
Used symbols:

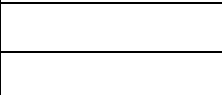
|   |  |
|---|--|
|    | <p>Direct current</p>  |
|    | <p>Alternating current</p>   |
|    | <p>Three phase alternating current</p>                                   |
|    | <p>Earth (ground) terminal</p>   |
|   | <p>Protective conductor terminal IEC 417, No. 5019</p>                   |
|  | <p>Caution, risk of electric shock<br/>ISO 3864, No. B.3.6</p>           |
|  | <p>Caution (refer to accompanying documents)<br/>ISO 3864, No. B.3.1</p> |
|  | <p></p>  |

## 12 Index

---

### *I*

|                              |    |
|------------------------------|----|
| 10/700 µs Tester             |    |
| Verification by the customer | 37 |

---

### *A*

|                           |        |
|---------------------------|--------|
| Attention refer to manual | 22; 27 |
|---------------------------|--------|

---

### *C*

|                              |    |
|------------------------------|----|
| CDN2000                      |    |
| Block diagram                | 17 |
| Technical Data               | 15 |
| Check before operation       | 27 |
| Climatic Condition           | 21 |
| Combination Wave Test        |    |
| Introduction                 | 7  |
| Combination Wave Tester      |    |
| Verification by the customer | 37 |
| Control panel                |    |
| Front panel                  | 25 |
| Coupling network             | 53 |
| CWG                          | 53 |

---

### *D*

|                                   |    |
|-----------------------------------|----|
| Damped Oscillatory coupling       |    |
| Front panel                       | 31 |
| Damped Oscillatory Wave 0,1/1 MHz |    |
| General                           | 12 |
| Decoupling network                | 53 |

---

### *E*

|                               |    |
|-------------------------------|----|
| EFT                           |    |
| General                       | 12 |
| EFT coupling                  |    |
| Front panel                   | 30 |
| Electromagnetic Compatibility | 22 |
| EMC                           | 53 |
| EUT                           | 53 |
| EUT Power connection          |    |
| Front panel                   | 28 |

---

### *H*

|              |    |
|--------------|----|
| Hybridimpuls | 53 |
|--------------|----|

---

### *I*

|                      |    |
|----------------------|----|
| I/O lines connection |    |
| Front panel          | 28 |

---

### *M*

|                       |    |
|-----------------------|----|
| Maintenance           | 37 |
| Mechanical dimensions | 18 |
| CDN2000-06-25 Tester  | 18 |
| MIG tester 6 kV       |    |
| General               | 14 |

---

### *O*

|                        |    |
|------------------------|----|
| Operational Conditions | 21 |
|------------------------|----|

---

### *P*

|                                 |    |
|---------------------------------|----|
| Packaging and shipment          | 43 |
| Power supply, power consumption | 18 |
| Putting out of operation        | 41 |

---

### *Q*

|            |    |
|------------|----|
| Quickstart | 35 |
|------------|----|

---

### *R*

|                              |    |
|------------------------------|----|
| Recycling/Disposal           | 45 |
| Ring Wave coupling           |    |
| Front panel                  | 29 |
| Ring Wave Tester             |    |
| Verification by the customer | 37 |
| Ring Wave Tests              |    |
| General                      | 9  |

---

### *S*

|                       |    |
|-----------------------|----|
| Safety                |    |
| Precautionary measure | 22 |
| Standards             | 21 |
| Seminars              | 27 |
| Service, Repair       | 39 |
| Surge coupling        |    |
| Front panel           | 29 |
| Symbols               | 54 |

---

### *T*

|                         |    |
|-------------------------|----|
| Test                    | 53 |
| Test set-up combination |    |
| Hints to test set-up    | 32 |
| Test set-up Ring Wave   |    |
| Hints to test set-up    | 33 |
| TRA-EFT-SURGE           |    |
| General                 | 14 |





## 13 Annex

### 13.1 Damped oscillatory on power supply

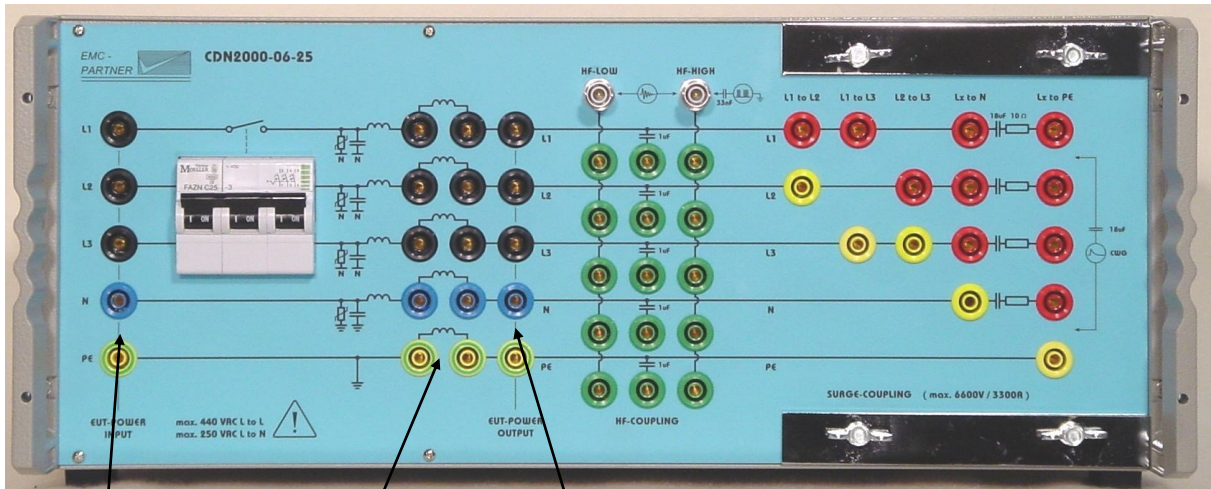

Power input  
L1, L2, L3, N,  
PE

Remove all 5  
bridges

Power output  
L1, L2, L3, N,  
PE

### 13.2 Damped oscillatory on I/O lines

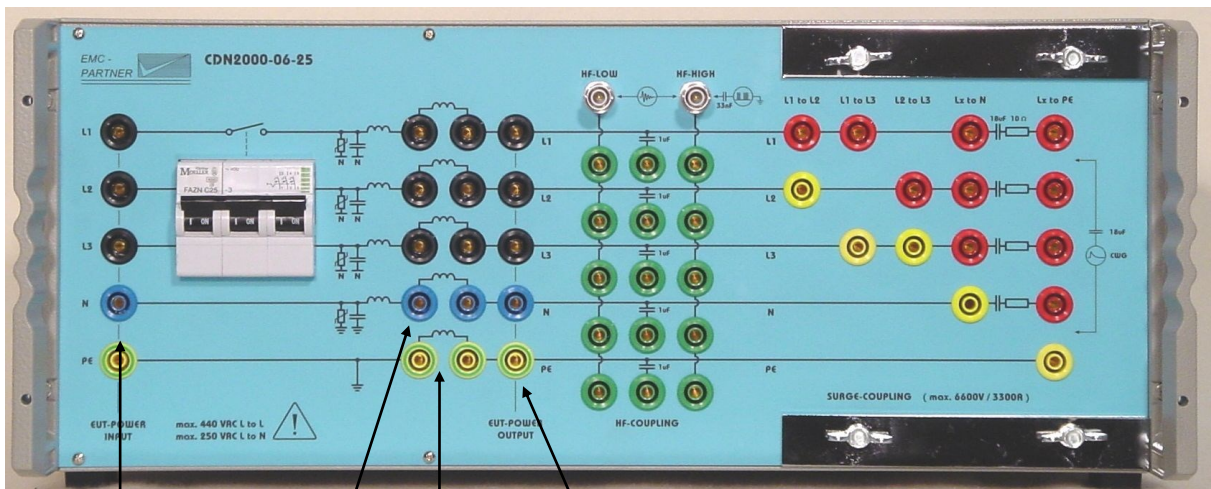

Remove power  
input L1, L2,  
L3, N, PE

I/O lines  
inputs

Remove all 5  
bridges

I/O lines  
output











the five black bridges must only be inserted for SURGE and Ring Wave tests



### 13.3 Assembly Instruction to MC Connectors

skaw

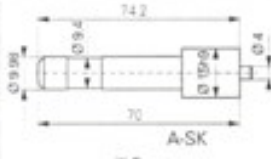
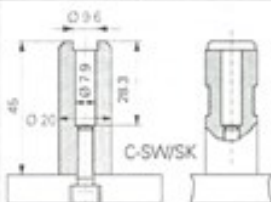
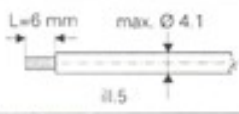
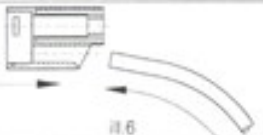
|   |  |   |  |  |
|---|--|---|--|--|
|    | <p><b>Multi-Contact AG Basel</b><br/>                 Stockbrunnrain 8<br/>                 Postfach<br/>                 CH-4123 Allschwil 1<br/>                 Tel.: 061/302 45 45<br/>                 Fax: 061/302 45 68</p>   | <p><b>Multi-Contact Deutschland GmbH</b><br/>                 Hegeheimer Strasse 19<br/>                 Postfach 1606<br/>                 D-79551 Weil am Rhein<br/>                 Tel.: 07621/667-0<br/>                 Fax: 07621/667-100</p>  | <p><b>Multi-Contact France S.A.</b><br/>                 4, rue de l'industrie<br/>                 Zone industrielle<br/>                 F-68220 Hémingue<br/>                 Tel.: 89 67 65 70<br/>                 Fax: 89 69 27 96</p> |  |
| <p><b>Montageanleitung</b></p> <p><b>Sicherheitsverbindungsleitungen<br/>                 SLK425-K, SLK425-K SII, SLK410-K SII</b></p> <p>Bei der Benutzung von anderen als von MC<sup>®</sup> angegebenen Einzelteilen und Werkzeugen, kann bei der Selbstkonfektionierung weder die Sicherheit, noch die Einhaltung der technischen Daten gewährleistet werden. Silikonleitungen sollten nach Möglichkeit konfektioniert bei MC<sup>®</sup> bezogen werden.</p> | <p><b>Assembly Instructions</b></p> <p><b>Safety Connecting Leads<br/>                 SLK425-K, SLK425-K SII, SLK410-K SII</b></p> <p>The use of parts and tools other than those stated by MC<sup>®</sup> can have an effect on the safety and quality of the do-it-yourself leads and therefore the technical data cannot be guaranteed. When possible, leads made with silicon cable should be ordered ready-made from MC<sup>®</sup>.</p> | <p><b>Instructions de montage</b></p> <p><b>Cordons de sécurité<br/>                 SLK425-K, SLK425-K SII, SLK410-K SII</b></p> <p>Ni la sécurité, ni les données techniques ne sont garanties, si lors de la conception personnelle, des pièces et outillages autre que MC<sup>®</sup> sont utilisés. Les cordons en silicone devront dans la mesure du possible être achetés, confectionnés par MC<sup>®</sup>.</p> |  |  |
|    |  <p>1</p>   |  <p>2</p>  |  <p>3</p>  |  <p>4</p> |
|   | <p>LS425-SK<br/>22 1022</p>  | <p>HK2 5-D HK2 5-SII<br/>22 0130 22 0680<br/>HK1 5-II/1000<br/>22 0170</p>  | <p>V-KT425-SK<br/>22 5620</p>  | <p>KT425-SK<br/>22 2300<br/>H-KT425-SK<br/>22 5630</p>                                       |
|  <p>ii.1</p>  | <p><b>Notwendiges Werkzeug</b></p> <p>(ii.1)<br/>                 Abisolierzange "Stripax"<br/>                 Bestellnr. 25.0015</p>   | <p><b>Tools required</b></p> <p>(ii.1)<br/>                 Cable stripper "Stripax"<br/>                 Order No. 25.0015</p>   | <p><b>Outillage nécessaire</b></p> <p>(ii.1)<br/>                 Pince à dénuder "Stripax"<br/>                 No. de Cde 25.0015</p>  |  |
|  <p>ii.2</p>   | <p>(ii.2)<br/>                 - Lötkolben 60 VA<br/>                 - Lötdraht<br/>                 z.B. Eisold Ø 1,5 mm<br/>                 DIN 8516 (L-Sn60PbCuZ)</p>   | <p>(ii.2)<br/>                 - Soldering iron 60 VA<br/>                 - Solder<br/>                 e.g. Eisold Ø 1,5 mm<br/>                 DIN 8516 (L-Sn60PbCuZ)</p>   | <p>(ii.2)<br/>                 - Fer à souder 60 VA<br/>                 - Fil de soudure<br/>                 p.e. Eisold Ø 1,5 mm<br/>                 DIN 8516 (L-Sn60PbCuZ)</p>  |  |
|  <p>ii.3</p>   | <p>(ii.3)<br/>                 Hilfswerkzeug A-SK<br/>                 Empfohlenes Material:<br/>                 Stahl.</p>   | <p>(ii.3)<br/>                 Auxiliary tool A-SK<br/>                 Recommended material:<br/>                 Steel.</p>   | <p>(ii.3)<br/>                 L'outil A-SK<br/>                 Matériel recommandé:<br/>                 Acier.</p>  |  |
|  <p>ii.4</p>   | <p>(ii.4)<br/>                 Hilfswerkzeug C-SW/SK<br/>                 Empfohlenes Material:<br/>                 Messing.</p>  | <p>(ii.4)<br/>                 Auxiliary tool C-SW/SK<br/>                 Recommended material:<br/>                 Brass.</p>  | <p>(ii.4)<br/>                 L'outil C-SW/SK<br/>                 Matériel recommandé:<br/>                 Laiton.</p>  |  |
|  <p>ii.5</p>   | <p><b>Vorbereitung der Leitung</b></p> <p>(ii.5)<br/>                 Leitung 2 auf gewünschte Nennlänge ablängen.</p>   | <p><b>Preparation of the cable</b></p> <p>(ii.5)<br/>                 Cut the cable 2 to the desired nominal length</p>   | <p><b>Préparation du câble</b></p> <p>(ii.5)<br/>                 Couper le câble 2 à la longueur prévue.</p>  |  |
|  <p>ii.6</p>   | <p>(ii.6)<br/>                 Leitung 2 durch isolierteil 4 schieben.</p>   | <p>(ii.6)<br/>                 Feed cable 2 through insulator 4.</p>  | <p>(ii.6)<br/>                 Glisser le câble 2 à travers l'isolant 4.</p>   |  |



Multi-Contact

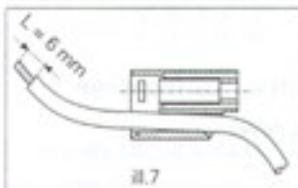

(ILL 7)  
Leitung mittels Abisolierzange auf Länge L = 6 mm abisolieren.

(ILL 7)  
Strip cable insulation to length L = 6 mm with cable stripper.

(ILL 7)  
Dénuder le câble sur la longueur L = 6 mm avec la pince à dénuder.

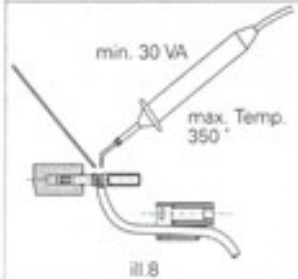

(ILL 8)  
Leitung 2 in Stecker 1 löten. Beim Löten darf der Stecker wegen dem Kunststoffkopf nicht zu heiss werden. Ideale Löttemperatur: ca. +350° C.

(ILL 8)  
Solder cable 2 in plug 1. When soldering the plug should not get too hot because of the plastic head. Ideal soldering temperature: approx. + 350° C.

(ILL 8)  
Solder le câble 2 dans la fiche 1. Lors de la soudure la température ne doit pas être excessive à cause de la tête en plastique. Température idéale de soudure: env. +350° C.

Stecker und Lötstelle müssen frei von austretendem Lötzinn sein.

Plug and solder area should be free from excess solder.

La fiche et l'endroit de soudure doivent être exempt de coulure de soudure.

**MC<sup>®</sup>-Empfehlung:**  
Ein Block mit Bohrung Ø 4,2 mm hält den Stecker 1 beim Löten fest.

**MC<sup>®</sup>-Recommendation:**  
For soldering purposes a block with a drilled hole Ø 4,2 mm should be used to hold the plug 1 in position.

**Recommandation MC<sup>®</sup>:**  
Utiliser un bloc avec un perçage Ø 4,2 mm pour maintenir la fiche 1 lors de la soudure.

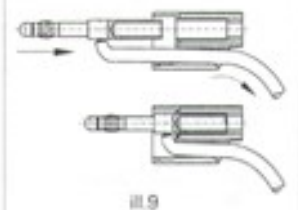

(ILL 9)  
Stecker 1 zurück in Isolierteil 4 einschieben und gleichzeitig die Leitung leicht nachziehen.

(ILL 9)  
Push plug 1 back into insulator 4 and at the same time take-up the wire.

(ILL 9)  
Insérer la fiche 1 dans l'isolant 4 et en même temps tirer légèrement le câble.

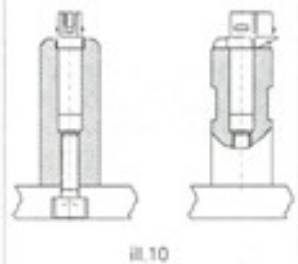

(ILL 10)  
Isolierteil 3 in Hilfswerkzeug C-SW/SK einlegen.

(ILL 10)  
Place insulator 3 into the auxiliary tool C-SW/SK.

(ILL 10)  
Mettre l'isolant 3 dans l'outil C-SW/SK.

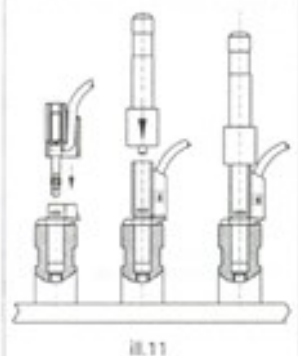

(ILL 11)  
Isolierteil 4 (+2+1) in Isolierteil 3 einschieben und mittels Hilfswerkzeug A-SK und einer Tischbohrmaschine oder Kniehebelpresse bis zum Einrasten einpressen.

(ILL 11)  
Insert insulator 4 (+2+1) into insulator 3 and with auxiliary tool A-SK mounted in a lever press or bench drilling machine, press and snap into position.

(ILL 11)  
Insérer l'isolant 4 (+2+1) dans l'isolant 3 et presser jusqu'au point d'arrêt avec l'outil A-SK à l'aide d'une perceuse ou d'une petite presse.

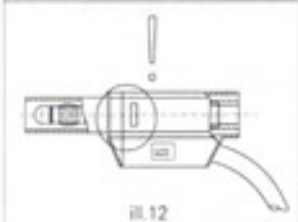

(ILL 12)  
Einrasten kontrollieren.

(ILL 12)  
Control snap in.

(ILL 12)  
Contrôler l'enclenchement

MA 105

Änderungen vorbehalten/Subject to alterations/Modifications sous réserve  
Copyright by Multi-Contact AG, Basel 3, Switzerland © MC-Lab-Doc 1500-1/95

13.4 Wire connection between MIG0603OMI and CDN2000-06-25

