



CBA POWER AMPLIFIER



Operation Manual

Manual number H012161

Revision: 3

First edition published 26th July 2017

Any disclosure to third parties, or reproduction by any means of any part of this manual without the written consent of Teseq, is prohibited.

For Sales

China

AMETEK Commercial Enterprise (Shanghai) Co. Ltd.

Beijing Branch
Western Section, 2nd Floor
Jing Dong Fang Building (B10)
Chaoyang District
Beijing, China, 100015
T +86 10 8526 2111
chinasales@teseq.com

Shanghai Office:

Part A1, A4, 2nd floor, Building No. 1
No. 526 Fute 3rd Road East
Pilot Free Trade Zone, Shanghai 200131,
China
T +86 21 5868 5111

Guangzhou Office:

Room 1410-12, Yian Plaza
33 Jian She Liu Ma Road
Guangzhou, China
T +86 20 8363 4768

Germany

AMETEK CTS Germany GmbH

Lünener Straße 211
59174 Kamen, Deutschland
T +49 2307 26070-0
sales.cts.de@ametek.com
service.rf.cts@ametek.com

Great Britain

AMETEK (GB) Ltd. trading as Teseq

5 Ashville Way, Molly Millars Lane
Wokingham
Berkshire RG41 2PL
Great Britain
T +44 845 074 0660
teseq-uk.service@ametek.com

Japan

AMETEK Co. Ltd.

Tokyo office
3rd floor, Shiba NBF Tower,
1-1-30 Shiba-Daimon, Minato-ku
Tokyo, 105-0012, Japan
T +81 3 6809 2401
cts-japan.sales@ametek.com

Nagoya Office

1-329 Kifune Meito-ku Nagoya-shi
Aichi-ken, 465-0058, Japan
T +81 52 709 5501

Poland

AMETEK CTS Germany GmbH

Biurowo w Polsce
ul. Ogrodowa 31/35
00-893 Warszawa, Polen
T +48 518 643 512
infopolska.cts@ametek.com

Singapore

AMETEK Singapore Pte. Ltd.

No. 43 Changi South Avenue 2
#04-01 Singapore 486164
T +65 6484 2388
singaporesales.cts@ametek.com

Taiwan

AMETEK Taiwan Corp. Ltd.

10F-5, No. 120, Sec 2,
GongDaoWu Rd.,
Hsinchu City 30072, Taiwan
T +886 3 57 5099
taiwan.sales.cts@ametek.com

USA

Teseq Inc. / AMETEK CTS

52 Mayfield Avenue
Edison, New Jersey 08837, USA
T +1 732 417 0501
Toll free: +1 888 417 0501
usasales.cts@ametek.com
usasupport.cts@ametek.com

Table of Contents

1	INTRODUCTION	5
1.1	About this manual	5
1.2	Amplifier description	5
2	SAFETY	6
2.1	General	6
2.2	Safety symbols and terms	6
2.3	Safety precautions	7
3	INSTALLATION	9
3.1	General	9
3.2	Connecting the line cord	10
3.3	Connecting the chassis ground cable	10
3.4	Connecting the RF cables	10
3.5	Connecting the Safety interlock	10
4	PROTECTION CIRCUITS	11
4.1	Over Heat Protection	11
4.2	Input Protection	11
4.3	Power Supply Faults	11
4.4	Mismatch Protection	11
5	AMPLIFIER OPERATION	12
5.1	Safety interlock Operation	12
5.2	Switching on line supply	12
5.3	Cooling Fan Operation	13
5.4	General	13
5.5	OPRT/STBY	13
5.6	FLT/RST	14
5.7	LOC/RMT	14
5.8	Gain Control	14
5.9	GPIB	15
6	INDICATORS & FUNCTIONS	15
6.1	General	15
6.2	Touch Screen Indication	15
7	CONNECTIONS	16
7.1	General	16
7.2	RF input, N Type connector	16
7.3	RF output N-Type or 7/16 (Model Dependent)	17
7.4	Sample Ports, N-TYPE Female	17
7.5	Line supply input connector	17
7.6	Safety interlock	18
7.7	IEEE-488 Convector	18
7.8	Ethernet	18
7.9	RS232 Connection	19
7.10	USB Connection	19
7.11	Ground post (8-32 thread)	19

8	REMOTE CONTROL CONNECTIONS & OPERATIONS.	20
8.1	Connectors	20
8.2	IEEE 488 Operation	20
8.3	RS-232 Operation	20
8.4	Ethernet Connection	21
8.5	USB Connection	21
8.6	Remote Command Set	22
9	ROUTINE MAINTENANCE	24
9.1	General cleaning	24
9.2	RF connectors	24
9.3	Air-filter cleaning.	24
10	FAULT FINDING	25
10.1	General checks	25
10.2	Fault indications	26
11	WARRANTY	28
11.1	Definitions	28
11.2	Scope	28
11.3	Terms and conditions	28
11.4	Transfer of Warranty	29
11.5	Protection of Warranty	29
11.6	Repair form	30
13.1	Fig 1, 3U front Panel & Outline Drawing	31
13.2	Fig 2, 4U Front Panel & Outline Drawing	32
13.3	Fig 3, 6U Front Panel & Outline Drawing	33
13.4	Fig 4, 10U Front Panel Drawing	34
14	DATASHEET SPECIFICATIONS	36

1 INTRODUCTION

1.1 About this manual



◆ **CAUTION!** This Operation Manual contains important information for the user of the amplifier. It details important safety information and hazards that can be encountered by the user, and recommends precautions that should be taken to prevent damage to the amplifier or associated equipment. It is important that this Operation Manual (including any information in the Appendices) is read before attempting to install or operate the amplifier.

This operation manual contains information that details installation, routine maintenance and amplifier operation. It does not contain information needed for servicing or calibration.

1.2 Amplifier description

The TESEQ CBA amplifier series is designed for laboratory use. The form factor ranges from 3U, 4U & 6U bench top units up to rack mountable 10U amplifiers consisting of a 7U power amplifier drawer and separate 3U power supply draw.

A CBA amplifier can be remotely controlled via the built in RS232, IEEE 488, USB or Ethernet amplifier controller. Local control is via a front panel touch screen. This also shows the amplifier status when controlled remotely.

A comprehensive performance and status indicating system is included. These circuits monitor:

- Interlock circuit status
- Forward power indication
- Reflected power indication
- High VSWR indication
- RF baseplate temperature
- Ambient temperature
- Power supply DC voltage
- Power supply DC current
- Overall status of the amplifier

Visual indications are given. If a fault is detected, the amplifier automatically reverts into a latched STANDBY condition. It remains in this condition until the fault has been cleared and the fault latch is reset via the front panel touch screen.

The design of the amplifier is subject to continuous improvement. Consequently, the amplifier may incorporate minor changes in detail from the information contained in this manual.

2 SAFETY

2.1 General

The amplifier described in this manual is designed to be used only by qualified personnel. Use of the amplifier in a manner not specified in this manual may impair the protection provided by the amplifier. Before use, inspect the amplifier for damage which may impair safety.

There are no user-serviceable parts inside the amplifier, and any warranty is rendered void if the seals on any covers are broken.

The following safety information is intended to protect all installers and operators, and to prevent damage to the amplifier. It should be read and understood before installing and operating the amplifier

2.2 Safety symbols and terms

◆ **CAUTION!** statements identify conditions or practices that could result in damage to the amplifier or other property.

◆ **WARNING!** statements identify conditions or practices that could result in personal injury or loss of life.

◆ **Note** statements inform the user of important general information.

◆ **Hints and tips** statements inform the user of useful information and operational short cuts.

The following symbols appear on the amplifier and in this manual:



When used on the amplifier, warns the user of a non-ionising radiation hazard. When used in this operation manual, alerts the user to the part of the manual that deals with a non-ionising radiation hazard.



When used on the amplifier, directs the user to refer to the operation manual. When used in this operation manual, alerts the user to ◆ **WARNING!** and ◆ **CAUTION!** statements.



or



Warns personnel to observe correct lifting practices.



Ground terminal. Connect this terminal to a clean ground to improve EMC immunity. Although it provides an extra measure of safety, this is **not** a protective earth ground. The protective earth ground is the pin on the line inlet connector.

2.3 Safety precautions

Observe all the following precautions to ensure personal safety and prevent damage to the amplifier or equipment connected to it.

◆ **WARNING! Properly dispose of the amplifier.**

The RF amplifier modules in this equipment contain Beryllium Oxide, and other components contain PTFE. The appropriate precautions and regulations must be observed concerning the disposal of this amplifier and certain internal components. **Do not crush or incinerate.**

◆ **Note:** Beryllium Oxide is a material used in the manufacture of RF devices. Toxic dust is given off when crushed.

◆ **Note:** PTFE is a material used in the manufacture of certain components within the amplifier. PTFE gives off toxic gasses when incinerated.

◆ **WARNING! Do not touch the inner conductor of the RF-output connector.**

High voltages can occur on the inner conductor of the RF output connector, or on cables or antennas connected to it. These can cause RF burns if touched.

◆ **WARNING! Ground the amplifier.**

The amplifier conforms with IEC Safety class 1, meaning that it is provided with a protective grounding terminal. This is through the line supply cord to the centre pin of the power inlet connector. To maintain this protection, the line supply cord must always be connected to the source of line supply via a socket with a grounded contact. Do this before making connections to the RF-input or RF-output connectors of the amplifier.

Without the protective ground connection, all parts of the amplifier constitute a potential shock hazard.

◆ **WARNING! Use the correct power cord.**

Use only the line supply cord and connector specified for the amplifier. Use only a line supply cord that is in good condition.

◆ **WARNING! Do not remove covers or panels.**

To avoid personal injury, do not operate the amplifier without the panels or covers in place.

◆ **WARNING! Do not operate in explosive atmospheres.**

The amplifier provides no explosive protection from static discharges or arcing components. Do not operate the amplifier in an atmosphere of explosive gasses.

◆ **CAUTION! Avoid static discharges**

The RF input and output connections are static-sensitive and should not be subjected to static discharge.

◆ **CAUTION! Use the correct line supply source**

It is essential that the amplifier operates from a line supply source that does not apply voltages and frequencies between the line supply conductors (or between either line supply conductor and ground) that are outside the range detailed in the specification sheet.

◆ **CAUTION! Do not obstruct the circuit breaker.**

Ensure that there are no obstructions that impair the operation of the front panel line-supply circuit breaker(s).

◆ **CAUTION! Do not obstruct the airflow through the amplifier.**

The cooling airflow is drawn in through the front and exhausted at the rear. If this airflow is obstructed, overheating of the amplifier may occur.

◆ **CAUTION! Do not operate the amplifier outside its specification.**

This may cause the amplifier to malfunction or be damaged.

◆ **WARNING! Do not touch the exterior of the amplifier (rack mount version) when in use.**

The top and side panels of the amplifier can get hot during use, especially on high power models.

◆ **CAUTION! Periodically replace the air-intake filters.**

Operating the amplifier with the air filters dirty may cause the amplifier to overheat.



or



◆ **CAUTION!**
Exercise caution when lifting.

The appropriate lifting practices should be observed during transportation, installation, or removal of the amplifier from its mounting position.



◆ **WARNING!**
Use the safety interlock facility within danger areas.

Any area where personnel may come into direct contact with high power RF, or be exposed to non-ionising radiation, should be designated as a danger area. A barrier should be established around any such area, with a switch in place when the barrier is broken. This switch can be linked to the safety interlock BNC connector on the amplifier, thus disabling the amplifier when the barrier is breached.

It is the responsibility of the operator to ensure that the working environment is safe. The 'safety interlock' feature is provided to assist the purchaser in establishing such a 'safe' area.

3 INSTALLATION

3.1 General



or



◆ **CAUTION!**
Exercise care when lifting.

Amplifier models that are very heavy have a caution label on the top cover. Appropriate lifting practices should be observed during transportation, installation, or removal of the amplifier from its mounting position. When mounted in a rack, the amplifier **must not** be supported by the front panel fixing holes alone. For easier installation and removal, we recommend that the amplifier is positioned with its top **no more than** 1.4 metres above ground level.



◆ **CAUTION!**
Do not support the whole weight of the amplifier with the front panel handles
(See Section 12)

These should only be used for sliding the amplifier in and out on the rack.

◆ **Note:** The amplifier may be lifted using the rear protection handles.
(See Section 12).

The amplifier is designed to be mounted in a 19" fixed rack installation. When mounted in a rack, use a support tray-slider-assembly, especially for heavy amplifier models. See the section 12 of this manual for details of amplifier dimensions.



◆ **CAUTION!**
Do not obstruct the airflow through the amplifier.

At least 200mm clearance should be allowed behind the amplifier, so that air flow and connecting cables are not obstructed. An unobstructed area of at least 200mm should be allowed in front of the amplifier front panel air-intakes.



◆ **CAUTION!**
Even though the ambient air temperature may be within the amplifier's specification, the internal temperature may rise above operational limits if it is operated in direct sunlight.

The cooling airflow is drawn in through the front and exhausted at the rear. If this airflow is obstructed, overheating of the amplifier may occur. For correct amplifier operation, airflow through the unit must be maintained.

3.2 Connecting the line cord



◆ **CAUTION!**

It is essential that the amplifier operates from a line source that does not apply voltages and frequencies between the line conductors (or between either line conductor and ground) that are outside the range detailed in the specification sheet.



◆ **CAUTION!**

Ensure that the line cord does not interfere with the operation of the rear panel line-input circuit breaker(s).

3.3 Connecting the chassis ground cable



To improve EMC immunity, bond the amplifier to a good ground with a conductor of 4 sq.mm or the equivalent earth braid, a ground post being provided for this purpose on the rear panel. Although it provides an extra measure of safety, this is **NOT** a protective earth. The protective earth is the ground pin on the line supply connector(s).

3.4 Connecting the RF cables



◆ **CAUTION!**

Ensure that the RF source is OFF when making connections.



◆ **CAUTION!**

Ensure any cables and connectors mating with the RF input and RF output connectors are of 50-ohm impedance, and are designed to handle the power at the frequencies generated by the amplifier. Although very similar, 75-ohm connectors must not be used.

Use cable with the lowest loss that is practical. The connectors should not be over-tightened, and any tightening instructions for the connector should be observed. Ensure that any bends in cables conform to the recommended minimum-bend-radius of those cables, especially where the cables enter the RF connectors.

3.5 Connecting the Safety interlock



◆ **WARNING!**

Use the safety interlock facility within danger areas.

If the amplifier is to be connected to an antenna, personnel may be exposed to non-ionising radiation. In such systems, the safety interlock function should be used.

Connection (via the rear panel) is with a BNC-type connector. We recommend that shielded cable is used for all interlock connections to ensure EMC immunity.

The current in the safety-interlock circuit is less than 1mA, so cable with a low current capacity is suitable.

If you do not need this function, fit the supplied BNC shorting-link in place. Failure to do this will result in the amplifier latching in an “Interlock Open” status which switches the amplifier into standby mode.

4 PROTECTION CIRCUITS

4.1 Over Heat Protection

The CBA RF components produce heat and are air cooled by fans. Should an over heat condition occur for any reason, the CBA contains heat sensors that will shut down the system via the amplifier control system. If the inlet and outlet openings are obstructed, clear the obstruction and allow the amplifier to remain in standby so that the internal fans can cool the amplifier down. Once the amplifier has reached an acceptable temperature, depress the “Fault Reset” soft key on the touchscreen and the amplifier will operate normally.

4.2 Input Protection

The CBA series is designed to achieve the specified output power level (see applicable datasheet) for an input level of 0 dBm or less (1.0mW) however, to prevent overdriving the amplifier, the Input Protection circuit will activate if the input signal exceeds 10 dBm and will automatically compensate for the increased input signal by reducing the gain of the preamplifier. Even though the amplifier has an Input Protection Circuit, overdriving the amplifier is not recommended.

IMPORTANT NOTE:

The CBA Sample Port connectors must be either connected to a 50Ω measurement system or terminated with the supplied 50Ω load. If the CBA is operated without 50Ω impedance on the Sample ports, the metering and output protection may be inaccurate, which may result in damaging the amplifier and voiding the unit’s warranty.

4.3 Power Supply Faults

The Power Supply Fault circuit monitors the voltage and current of system power supplies and produces a fault indication should any voltage or current level deviate from normal operating parameters. Each power supply voltage output is monitored and displayed to indicate the power supplies are operating within design parameters.

4.4 Mismatch Protection

The amplifier is not damaged by using it into a load that has a poor VSWR. While operating into a load that has poor VSWR, the amplifier may not deliver specified output power. In extreme cases, the amplifier folds back to protect internal circuitry.

5 AMPLIFIER OPERATION



◆ **CAUTION!**

Ensure that all the installation procedures detailed in Section 3 are complete before operating the amplifier.



◆ **CAUTION!**

Ensure that before connecting or turning the RF source ON, the input-source peak output level is set to less than the maximum level detailed adjacent to the RF input connector(s).

5.1 Safety interlock Operation



◆ **WARNING!**

Use the safety interlock function within danger areas.

Any area where personnel may come into direct contact with high power RF, or be exposed to non-ionising radiation, should be designated as a danger area. A barrier should be established around this area, with a switch opening when the barrier is broken. This should be linked to the safety interlock connector, disabling the amplifier when the barrier is breached. (It is the responsibility of the operator to ensure a safe working environment).

Safety interlock connections are via a BNC connector on the rear panel. This should be used with an appropriate switching or control arrangement so that the amplifier is disabled when any barrier to a dangerous area is broken. Once the interlock connection is broken the amplifier will default to standby mode. Once the interlock connection is remade the amplifier will automatically resume operation in “Operate Mode”

5.2 Switching on line supply

After ensuring that the amplifier front panel rocker switch is in the down position (off) ensure the mains lead is connected to the correct AC line source. Depending on the model of CBA,

- 1 Switch the rear panel 3 phase circuit breaker to the “On” position. The rear panel circuit breaker provides AC overcurrent protection. There will be no amplifier indication as a result of this step.
- 2 Switch the front panel rocker switch to the Up (On) position. The touchscreen will indicate that the boot up process has begun.

◆ **Hints and tips:** This switch can remain in the ON position all the time, but it is best set to OFF when the amplifier is not being used for long periods.

5.3 Cooling Fan Operation

Once the amplifier has been turned on, the power supply fan will start along with the rear panel cooling fans. The CBA B series uses a forced air cooling system where air is drawn in to the front grill and exhausted out of the rear of the amplifier. Temperature sensitive fan circuits are used for optimal audible noise when the amplifier is in use. When in standby mode the fans will operate at their slowest speed, once the amplifier is set to, “Operate” mode, the RF modules will be enabled and start to generate heat. The fans will slowly increase in speed until the amplifier has reached thermal equilibrium.

◆ **Hints and tips:** The air intake/exhaust should be kept clear at all times. If they are blocked for any reason the amplifier will overheat and fault latch. Once the internal amplifier temperature has cooled to within normal operating conditions the fault can be reset and normal operation resumed.

5.4 General

When the front panel rocker switch is switched Up to the, “ON” position the Teseq splash screen will appear on the touch screen display. The amplifier will remain in this state for a maximum of 45 seconds while the amplifier controller completes its boot sequence.



5.5 OPRT/STBY

The operate/standby button controls the RF On/Off function of the amplifier. In standby the DC power supply is in the, “Off” state and the amplifier is in standby mode (RF Off).



Once pressed the OPRT/STBY button will illuminate green. This will indicate the DC power supply has energised supplying voltage to the power modules and the amplifier is in, Operate mode (RF On)



5.6 FLT/RST

The Fault/Reset (FLT/RST) will illuminate red when a fault is detected. Once the fault is removed/fixed depressing the FLT/RST will clear the fault indication so that normal operation of the amplifier can resumed.

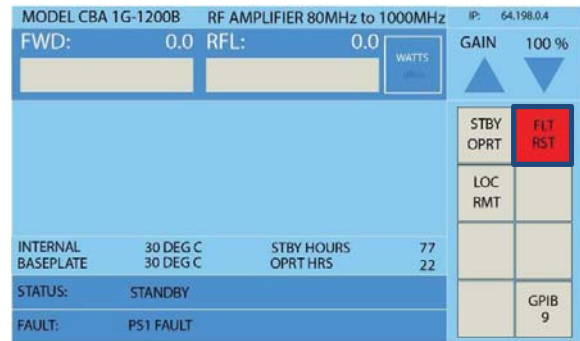

5.7 LOC/RMT

When the amplifier receives a remote command the LOC/RMT will illuminate green. Depressed the button will restore the amplifier to local operation



5.8 Gain Control

The gain control button allows for gain adjustments over the entire operating frequency of the amplifier over a range of 30dB in 100 steps via the touch screen. 255 steps via the remote command function.

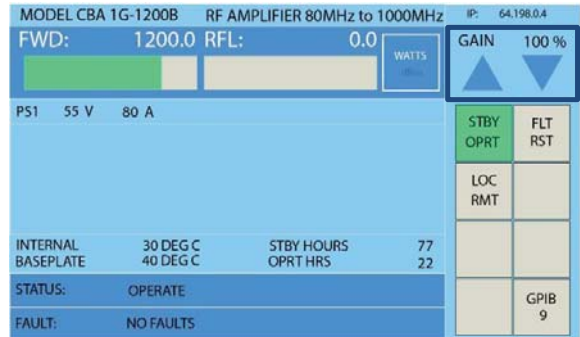

5.9 GPIB

The GPIB address can be changed by pressing the GPIB button. Pressing the button will cycle through the available addresses.

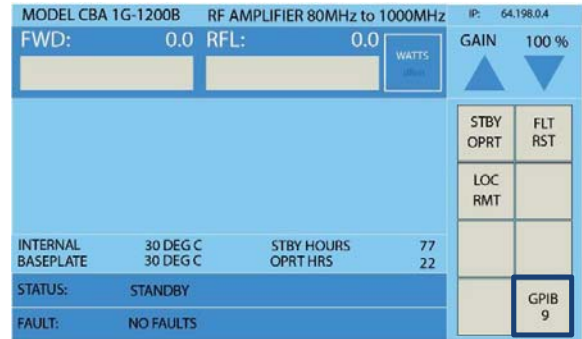

6 INDICATORS & FUNCTIONS

6.1 General

◆ **Note:** The front panel touch screen shows the amplifier status for both local and remote-control conditions.

6.2 Touch Screen Indication

	Display Indication	Display Function
1	Amplifier model number and frequency range of operation	Amplifier model number and frequency range of operation identification
2	Forward and reflected power indication	Mismatch load conditions as forward and reflected power in watts
3	PSU voltage and current	VDC PSU in Amps & Volts status
4	Internal Temperatures	Internal and baseplate temperature status
5	Hours of operation	Elapsed time indication of STBY/OPRT hours
6	Status. Operate/Standby	Operate and standby indication
7	Fault status.	Thermal, PSU or Interlock fault status

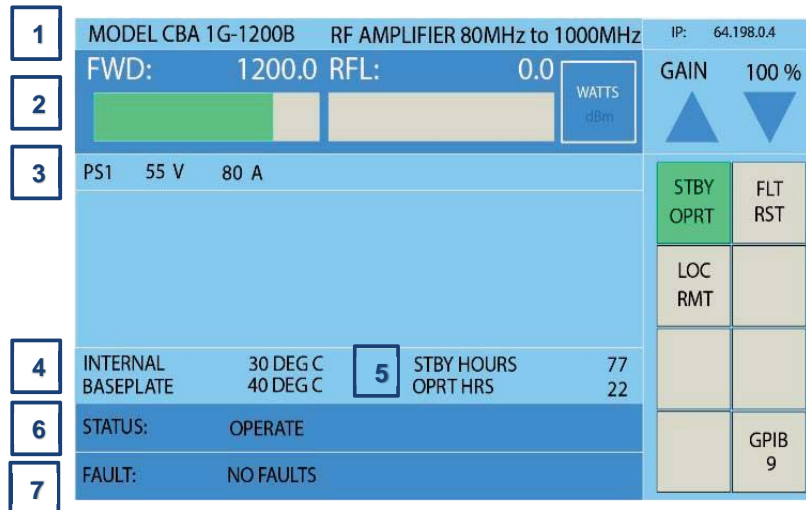

7 CONNECTIONS

7.1 General

The CBA series has an RF In, RF Out and a built in dual directional coupler with N-Type forward and reflected connections. These are available in two configurations, either all on the front or all on the rear of the amplifier. The CBA series are equipped with either a N-Type or a 7/16th RF output connector (model dependent, see applicable datasheet) but the same standard shall still apply; all RF connections are either on the rear or on the front of the amplifier. The interlock, remote connections, AC connector, and interconnecting cables are always located on the rear panel.

Summary

Front Panel		Rear Panel	
Function	Comment	Function	Comment
Amplifier Mains Breaker		3 Phase Main Breaker	Model Dependent
Local/Remote Switch	Touch Screen	Amplifier Tray & PSU Tray DC Power interconnect.	Model Dependent
RF On/Off Switch	Touch Screen	AC Power Connector	
Fault/Reset Switch	Touch Screen	Interlock, BNC	
Colour Touch Screen Display Status	Touch Screen	IEEE 488, Connector	
Gain Control,	Touch Screen	Ethernet	
		RS232	
		USB	
		Ground Post	

Front or Rear Panel RF Connectors	
Function	Comment
RF Input & Output	Configuration Dependent
FWD/RFL Sample Ports	Configuration Dependent

7.2 RF input, N Type connector



◆ **CAUTION!**

The maximum input level detailed in the specification sheet and on the amplifier front panel must not be exceeded. Do not expose the centre pin of the RF-input connector to static discharge. The signal source must be at DC zero.

Refer to the specification sheet for details of RF input levels. The nominal input impedance is 50 ohms.

◆ **Hints and tips:** Don't forget that modulated or complex signals may have a peak power that may not be indicated on the signal source. Always ensure that the peak level of the input signal is within the limits specified in the applicable datasheet.

7.3 RF output N-Type or 7/16 (Model Dependent)



◆ **WARNING!**
High RF voltages can occur on the inner conductor of the RF-out connector, which could cause RF burns if touched. Do not expose the centre pin to static discharge.

The nominal RF output impedance of the amplifier is 50 ohms, but it will safely drive a load with an input impedance other than 50 ohms (resistive or reactive), but will deliver less power. Refer to the specification sheet for details of RF output power.

7.4 Sample Ports, N-TYPE Female

These allow monitoring of both the incident power (P_i) and the reflected power (P_r) at low level.

The nominal output impedance is 50 ohms, and each output should be connected to a 50Ω test system or terminated with 50Ω load supplied with the amplifier.

Nominal Output Impedance (ohms)	Amplifier Power Level (Watts)	Nominal Output Level (dBc)	Flatness (dB)
50	<700	40	+/- 3
50	> 700	50	+/- 3

The above parts can be supplied as spares or replacement items. The part number must be quoted when ordering.

7.5 Line supply input connector

The CBA series power supply is equipped with a IEC or Neutrik Powercon inlet for single phase models and a high current 3 phase / 5 wire MS connector for high power models. The amplifier systems are supplied with mating power cords.

Rear Panel Single Phase IEC



Rear Panel Single Phase Neutrik 'Powercon'



3 Phase 5 Wire MS Connector

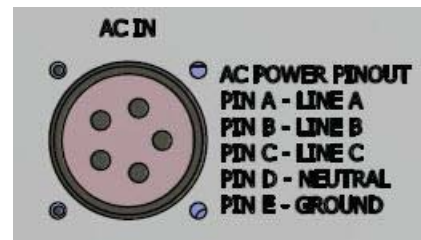

◆ **Note:** Mains inlet connectors are model dependent.

7.6 Safety interlock

Rear Panel mounted BNC jack receptacle.
50Ω impedance.
+5 Volts (current limited)

This connector is supplied with a shorting-link for use when the safety interlock function is not required.



7.7 IEEE-488 Connector

24 Way IEEE Bulkhead Connector.

Pin	Signal	Pin	Signal
1	Data IO1	13	Data IO5
2	Data IO2	14	Data IO6
3	Data IO3	15	Data IO7
4	Data IO4	16	Data IO8
5	End or Identify	17	Remote Enable
6	Data Valid	18	GND
7	Not Ready for Data	19	GND
8	No Data Accepted	20	GND
9	Interface Clear	21	GND
10	Service Request	22	GND
11	Attention	23	GND
12	Shield	24	GND Logic



7.8 Ethernet

RJ45 remote interface with signalling LED's

Pin	Signal
1	Transmit (TX+)
2	Transmit (TX-)
3	Receive (RX+)
4	NC
5	NC
6	Receive (RX-)
7	NC
8	NC



7.9 RS232 Connection

Pin Female D-Type

Pin	Signal
1	Data Carrier Detected
2	Receive (RX)
3	Transmit (TX)
4	Data Terminal Ready
5	Signal Ground
6	Data Set Ready
7	Request to Send
8	Clear to send
9	Ring Indicator



7.10 USB Connection

USB-B device connector

Pin	Signal
1	VDC (5V)
2	Receive (RX)
3	Transmit (TX)
4	Data Terminal Ready



7.11 Ground post (8-32 thread)



To improve EMC immunity, bond the amplifier to a clean ground with a conductor of 4 sq.mm or the equivalent braid, to this post. Although it provides an extra measure of safety, this is not a protective earth. The protective earth is the ground pin on the line inlet connector.

8 REMOTE CONTROL CONNECTIONS & OPERATIONS.

8.1 Connectors

IEEE 488.2	24 Way IEEE connector
RS232	9 pin female D-type
LAN	RJ45 with signalling LED's
USB	USB-B device connector

8.2 IEEE 488 Operation

The Teseq Amplifiers can be operated remotely from a computer having an IEEE-488 interface. This interface allows the amplifier to be remotely controlled over the General-Purpose Interface Bus (GPIB) by sending commands to the amplifier. Additionally, amplifier status and forward and reverse power readings may be read over the GPIB. All functions can be controlled by coded messages sent over the interface bus via the 24-pin socket connector on the rear panel of the unit. The GPIB command codes for the TESEQ Amplifier series are discussed on subsequent pages and, for ease of identification; the command codes are identified within the text by bold capital characters. For full information on the IEEE protocols and syntax the IEEE-488.2 Standard should be consulted.

When the amplifier receives a command over the GPIB, it automatically switches to REMOTE operation, pressing the LOCAL key on the front panel returns the unit to normal manual local operation. The initial state of the amplifier after power-on is the full attenuation condition.

◆ **Note:** The ZEROATT command must be set in order for the amplifier to be able to generate output power.

The GPIB address of the amplifier is set by via the Front panel using the touch screen control button.

8.3 RS-232 Operation

For operation of the serial port a terminal application is required to be configured with the following port configuration. Connect the RS232 cable and power the amplifier up.

◆ **Note:** To determine which COM port is being used for a specific protocol, navigate to **CONTROL PANEL** and double-click on the **SYSTEM** icon. Once under **System Properties**, navigate to the **HARDWARE** tab and select **DEVICE MANAGER**. Scroll down until you see **PORTS (COM & LPT)** and expand the drop-down menu. The associated port should be listed.

◆ **Note:** Teseq doesn't recommend the use of USB to serial adaptors unless the adaptor contains an FTDI chip set.

Configure the selected Port as per the below settings.

RS-232 / USB Configuration Settings		
	RS-232	USB
Bits per second	9600	9600
Data Bits	8	8
Parity	None	None
Stop Bits	1	1
Flow Control	None	None

To place the amplifier in remote operation type in a valid command such as "STATUS". The amplifier will then go into remote operation and the status will be displayed on the computer.

8.4 Ethernet Connection

With the amplifier powered down connect via an Ethernet cable to the network. Power the amp up and wait (5/10 seconds) for the amplifier to acquire an IP address dynamically. The acquired IP address will then be displayed on the touch screen in the top right-hand corner.

◆ **Note:** The port number is 10001 and a DHCP server is required to address the amplifier.

To assign a static IP to the amplifier, you must first establish a remote connection. Once connected, type the command **Settings** to enter the **User Settings Mode**. Once in this mode, you can enter the command **Edit** to begin configuring the static IP settings. The **Edit Settings Values** are as follows:

STATIC IP	Y/N
STATIC IP Value	XXX.XXX.X.XX
SAVE SETTINGS	Y/N

8.5 USB Connection

◆ **Note:** A USB cable with an FTDI chip set is required for this form of communication.

FTDI drivers are required to assign the USB interface a virtual com port. If these are not installed on the PC in use they can be downloaded from, <http://www.ftdichip.com/FTDrivers.htm>

Ensure the drivers are loaded and installed on the PC in use before connecting via USB. With the amplifier powered down connect to the USB interface. Power the amplifier up and the interface will be assigned a virtual com port. The COM Port number can be discovered as per the RS232 method (8.3). Again, a terminal application will be required to communicate with the amplifier using the same setting as per the RS232 method (8.3)

8.6 Remote Command Set

Amplifier Status Commands	
MODEL	Display Unit Model
SN	Display Unit Serial Number
*IDN?	Model, S/N, Firmware Version
*RST	Restarts the Amplifier
STATUS	Display Amplifier Status Message
FAULT	Display Amplifier Fault
RESET, RE	Reset Amplifier Fault
*SCREENSHOT	Takes a screenshot of the display

Amplifier Operate Commands	
ON, OP, OPRT, RFOP, RFON	Turns the Amplifier On
OFF, STBY, OF, STB, RFOF	Turns the Amplifier Off

BAND_STATUS	Query Current Amplifier Band
BAND1	Switch to Band 1
BAND2	Switch to Band 2

Amplifier Pulse Commands	
PULSEW	Display Pulse Width
DUTYCYC	Display Duty Cycle
FRQNCY	
PERIOD	
CW_ON	Switch to CW Operation
PLS_ON	Switch to Pulse Operation
PLS/CW_STATUS	Query current mode

Amplifier Temperature Metering Commands	
TEMP-BASE	Query the Amplifiers Base Plate Temperature
TEMP-AMB	Query the Amplifiers Ambient Temperature

Amplifier Elapsed Time Metering Commands	
TOTALH	Total Amplifier ON Hours
OPERATEH	Total Amplifier OPERATE Hours

Amplifier RF Power Metering Commands	
POWERFWD	Report FWD Power (Watts)
POWERFWDDB	Report FWD Power (dBm)
POWERRFL	Report RFL Power (Watts)
POWERRFLDB	Report RFL Power (dBm)
RP	Report Power (FWD, RFL)

Amplifier Gain Control	
GAIN	Display Gain Level
SETGAINxxx	Set specific gain level
ZEROATTN	Set Gain to 100%
FULLATTN	Set Gain to 0%
ATTUxxx	Attenuation Up
ATTDxxx	Attenuation

Amplifier Power Supply Metering Commands	
PS1V	Power Supply 1 Voltage
PS1I	Power Supply 1 Current
PS2V	Power Supply 2 Voltage
PS2I	Power Supply 2 Current
PS3V	Power Supply 3 Voltage
PS3I	Power Supply 3 Current
PS4V	Power Supply 4 Voltage
PS4I	Power Supply 4 Current

Amplifier Power Supply Metering Commands	
PAIALL	Display all PA Currents
PA1I	Module 1 Current
PA2I	Module 2 Current
PA3I	Module 3 Current
PA4I	Module 4 Current
PA5I	Module 5 Current
PA6I	Module 6 Current
PA7I	Module 7 Current
PA8I	Module 8 Current
IPAIALl	Display all IPA Currents
IPA1I	Intermediate Power Module 1 Current
IPA2I	Intermediate Power Module 2 Current

9 ROUTINE MAINTENANCE

9.1 General cleaning

For cleaning the front panel, use an anti-static foam cleaner and a soft lint-free cloth or tissue. Using abrasive materials or strong solvents may damage the surface finish or the front panel overlay.

9.2 RF connectors

If the RF connectors are used frequently, or left disconnected for long periods, there is a tendency for dirt and oxide deposits to build up. This increases the contact resistance and creates localised heating of the RF OUT connector pin, which may cause damage on high power models. Periodically inspect the inner pins of the RF connectors for damage or deposits, and carefully clean if required.



◆ CAUTION!

Do not use cleaning materials that leave a residue or that are abrasive for cleaning the RF connectors, as this seriously degrades their performance.

When storing the amplifier for long periods, the RF connectors should be protected with the plastic covers provided.

9.3 Air-filter cleaning.



◆ CAUTION!

Operating the amplifier with the air-filter clogged, may cause the amplifier to overheat.

The air-intake-filter on the amplifier front panel should periodically be checked for cleanliness. If it is seen to be obstructed with any dust or debris this should be cleaned away before the amplifier is operated.

10 FAULT FINDING

10.1 General checks

These are simple checks the user can perform to establish the cause of any amplifier malfunction. The following procedures are by no means comprehensive, and do not disclose any obscure fault with the amplifier or any system it may form a part of.

Amplifier Won't Power Up at Mains Switch on.

- Ensure that the line cord is properly installed.
- Ensure that the line cord or connector is not damaged.
- Ensure that the 3-phase line circuit-breaker (model dependent) and front panel rocker switch is switched on.
- Ensure that the line circuit-breaker is not in the tripped condition.

◆**Note:** If the line circuit-breaker trips, there is a fault with the power supply and the amplifier must be returned to TESEQ for repair. There are no user-replaceable fuses in the amplifier.

No RF Output

- Ensure that the correct safety interlock signal is present. If the Interlock facility is not used, ensure that the Interlock shorting-link (rear panel) is inserted.
- Ensure that the touch screen Operate/Standby button is illuminated green.
- Ensure that the RF cables and connectors are mated correctly.
- Ensure that there is no damage to any of the RF connectors or cables, especially where the cable enters the connector.
- Ensure that the touch screen FLT/RST fault light is not illuminated red.
- Ensure that the RF input level is within specification.

RF present but at reduced level

- Ensure that the gain control is set to 100%
- Ensure that the RF cables and connectors are mated correctly.
- Ensure that the inner pins of the RF connectors are clean.
- Ensure that the RF load is 50 ohms.
- Ensure that there is no damage to any of the RF connectors or cables, especially where the cable enters the connector.
- Ensure that the RF input level is within specification and that the gain adjustment is set as expected.

◆**Note:** If the above checks have been done and the RF output is still at reduced level, there is probably a fault with the RF modules, in which case the amplifier must be returned to TESEQ for repair.

Amplifier not responding to remote commands

- Ensure that the remote connector is mated properly.
- Ensure that the 'REMOTE' indicator is illuminated on the touch screen. If not, send a, "OPRT" command.
- Ensure that there is no damage to the remote connector or cable, especially around where the cable enters the connector.

10.2 Fault indications

HIGH VSWR

High VSWR is seen when high levels of output power are reflected into the amplifier. The internal diagnostics determine if this state exists.

◆ **Note:** The amplifier will not be damaged by using it with a high VSWR. It might be that the load naturally has a poor VSWR – this just means that the full output power of the amplifier cannot be delivered to the load. The function of the indication is not to protect the amplifier. It is there to alert the operator that there has been a change in the system operating conditions.

- Ensure that the RF cables and connectors are mated correctly.
- Ensure that the RF load is 50 ohms.
- Ensure that the inner pins of the RF connectors are clean.
- Ensure that there is no damage to any of the RF connectors or cables, especially around where the cable enters the connector.

Interlock

Is indicated on the display in the amplifier status section when the continuity of the safety interlock circuit is broken, or the interlock control signal is not present.

- Ensure that there is continuity through the safety interlock switch and wiring (if used).
- Ensure that the safety interlock connector or shorting-link is properly mated.
- Ensure that the safety interlock control signal is present.

◆ **Note:** If no external safety interlock switch or control signal is used, connect the safety interlock shorting-link (rear panel).

Power Supply fault

When the power supply voltage or current is outside operational limits, a power supply fault is illuminated and the system enters standby mode.

- Ensure that the power supply air-filter insert is not clogged or obstructed. Clean as necessary.
- Ensure that the ambient temperature is within the amplifier specification.
- Ensure that there is at least the recommended clearance around the front and rear panel air vents.

- Ensure that for amplifier models with multiple line-input connectors, all connectors are connected to the line supply.
- Ensure that for models with more than one power supply, that all the rear panel circuit breakers are set to the ON position.

◆ **Note:** If the supply fault indicator is due to a high-temperature condition, cool the power-supply by leaving the amplifier in, “STANDBY” mode. The power-supply cooling fan (internal to the power-supply) can then reduce the power-supply temperature. If the supply fault indicator remains illuminated when the power-supply has cooled down, return the amplifier to TESEQ for repair.

Thermal Fault

A thermal fault is indicated on the display in the amplifier fault section when the temperature of the modules has risen above operational limits.

- Ensure that both rear panel fans are operating and not obstructed.
- Ensure that the air-filter inserts are not clogged or obstructed. Clean or replace if necessary.
- Ensure that the amplifier is not operating in direct sunlight.
- Ensure that the ambient temperature is within the amplifier specification.
- Ensure that there is at least the recommended clearance around the front and rear panel air vents.

◆ **Note:** To cool the RF modules down, leave the amplifier in the RF STANDBY condition so the cooling fans can reduce the RF module temperature. If the fans are not operating, or this indicator remains illuminated when the RF modules have cooled down, return the amplifier to TESEQ for repair.

If, after fault-finding, problems persist, contact TESEQ by telephone, fax or E-mail. It may be necessary to return the equipment to TESEQ for repair. See the Appendix 2 for details on how to do this.

11 WARRANTY

Teseq Ltd. Warrants that this product is free from defects in materials and workmanship for a period of:

- Three years on standard products
- one year on specifically designed products

11.1 Definitions

“Standard” means TESEQ commercial product which, from time to time, appears in its official marketing literature. It precludes product specifically designed to a Customer requirement.

11.2 Scope

TESEQ warrants to the owner of any standard, CBA-B, power amplifier product, purchased from TESEQ, its authorised dealers or resellers, that it will be free from defects in material and workmanship for a period of 3 years from the date of original shipment.

Should you encounter a problem within your first 3 years of ownership, we will have the unit collected and guarantee to apply our reasonable endeavours to have it repaired, and available for return, within 48 hours (6 working days) following receipt at our facility. All costs associated with the activity will be borne by TESEQ Ltd.

It is necessary for Customers to comply with the terms and conditions laid out below so that they may enjoy the benefits of the warranty.

In order to obtain service under this warranty, the Customer must notify TESEQ. (or one of its agents) of the defect before the expiration of the warranty period, using the ‘Returns Form’ from this handbook (or a photocopy of it).

11.3 Terms and conditions

TESEQ, or one of its authorised service centres, will, at its option, repair or replace any unit or component covered by this warranty which becomes defective, or malfunctions, under normal use / service during the period of this warranty, at no charge for parts, labour or shipping to the owner.

Components, or units, replaced under the terms of the warranty shall continue to have the benefit of the unexpired portion of the warranty only.

This warranty does not cover damage from customer accidents, misuse, abuse, misapplication, operation with incorrect AC voltage, operation with faulty associated equipment, unauthorised use by third parties other than the original customer, modification or alteration without prior factory approval, service by an unauthorised Service Centre and performance deterioration which will occur due to normal usage.

Units on which the serial number, or anti-tamper labels, has been removed or defaced are not eligible for warranty service. Evidence of alteration, erasing, or forgery of proof-of-purchase documents will be cause to void the warranty.

Units damaged due to the absence of routine maintenance, as defined by TESEQ in the product handbook, are not eligible for warranty service.

When product is to be returned for warranty service a return authorisation number must first be obtained from TESEQ. A description of the problem, as specific as possible, should be attached to the request for the return authorisation number.

11.4 Transfer of Warranty

This warranty can be transferred to any new owner by informing TESEQ within 30 days of ownership transfer.

TESEQ may, at its discretion, request that the amplifier is first returned to the factory, freight prepaid, to establish the condition of the amplifier and suitability for continuing warranty cover. Failure to notify TESEQ Ltd within 30 days will be cause to void the warranty.

11.5 Protection of Warranty

To protect your warranty, we recommend you:

- Ensure the product is serviced in accordance with the guidance laid out in the product handbook.
- Avoid unauthorised modifications to the product
Report any faults to TESEQ, or the nearest authorised dealer, as soon as they occur.

11.6 Repair form

<p>RETURN OF EQUIPMENT TO TESEQ REPAIR DETAIL</p>
--

NAME OF DISTRIBUTOR:	AMPLIFIER BEING RETURNED FROM:
MODEL No:	SERIAL No:
	PART No:
SHIPPING AGENT BEING USED:	EXPECTED DATE OF ARRIVAL AT TESEQ:
NATURE OF FAULT:	
WHEN DID THE FAILURE OCCUR:	
<p>For TESEQ Use Only:</p> <p style="text-align: center;">Returns No:</p> <p style="text-align: center;">Works Order No:</p>	

Please use this form for **ALL** amplifiers being returned for repair. Please give as many details as possible.

Teseq GmbH	Teseq Inc / AMETEK CTS
Landsberger Straße 255	52 Mayfield Avenue
12623 Berlin	Edison, New Jersey, 08837, USA
Telephone: +49 30 5659 880	Telephone: +1 732 417 0501
mailto:service.rf.cts@ametek.com	usasupport.cts@ametek.com

3 DRAWING SPECIFICATIONS

13.1 Fig 1, 3U front Panel & Outline Drawing

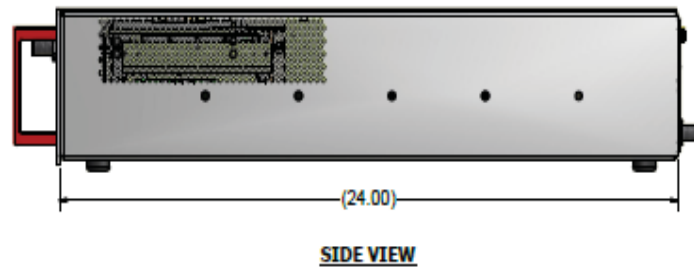
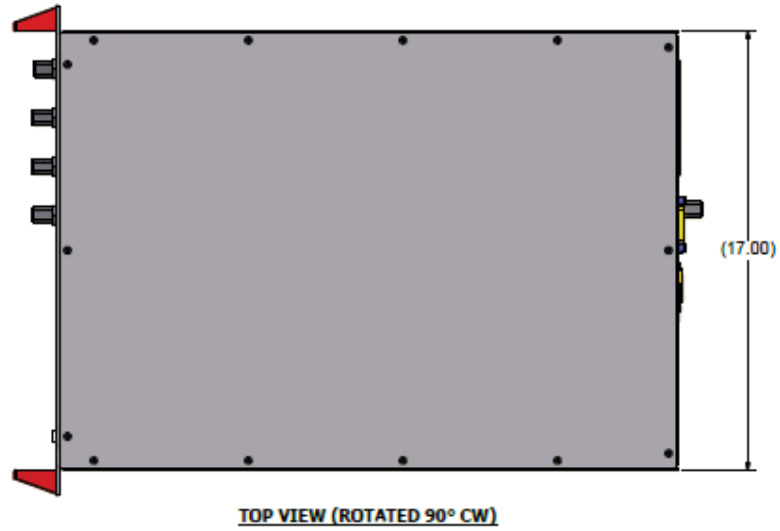
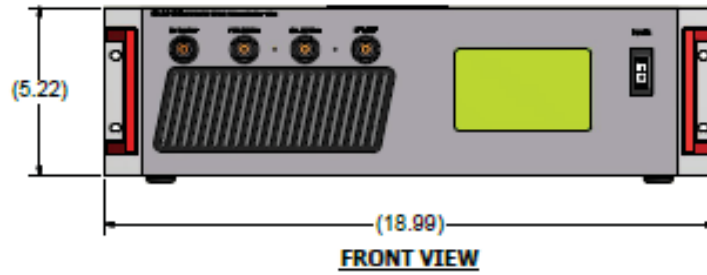

13.2 Fig 2, 4U Front Panel & Outline Drawing

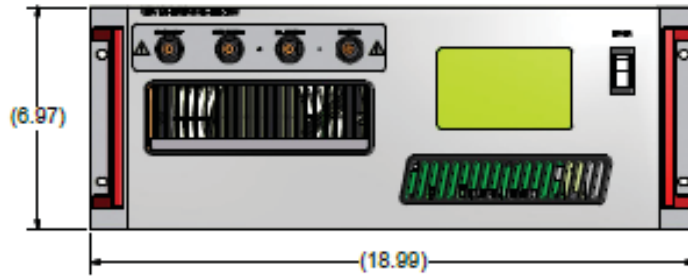

FRONT VIEW

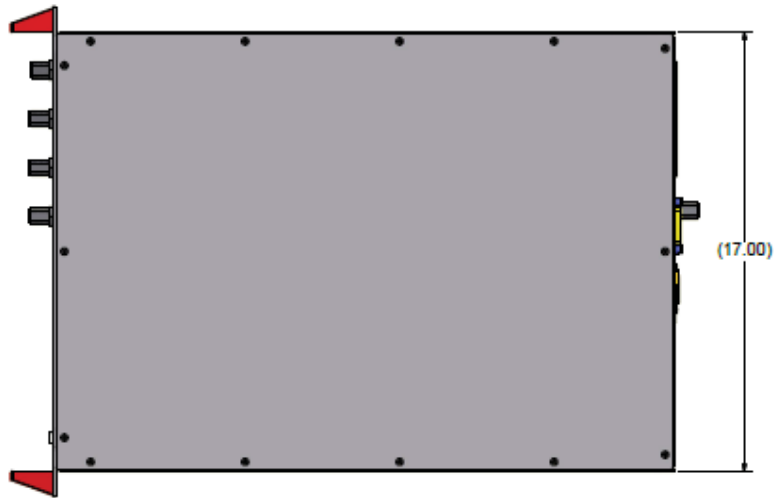

TOP VIEW (ROTATED 90° CW)

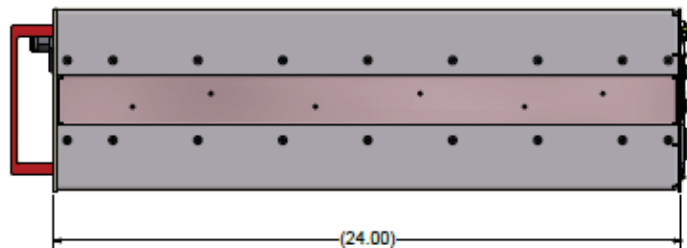

SIDE VIEW

13.3 Fig 3, 6U Front Panel & Outline Drawing

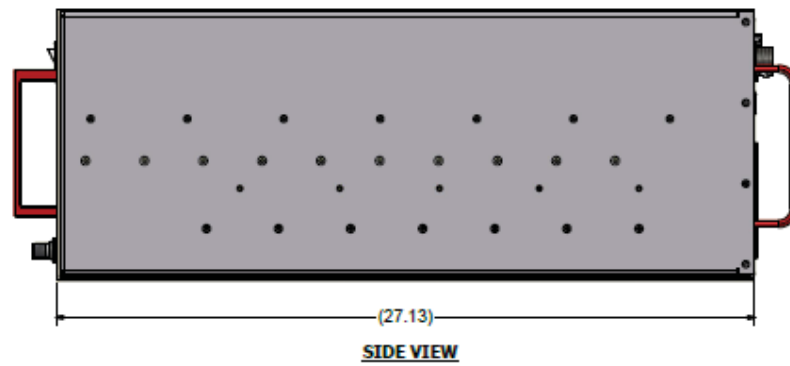
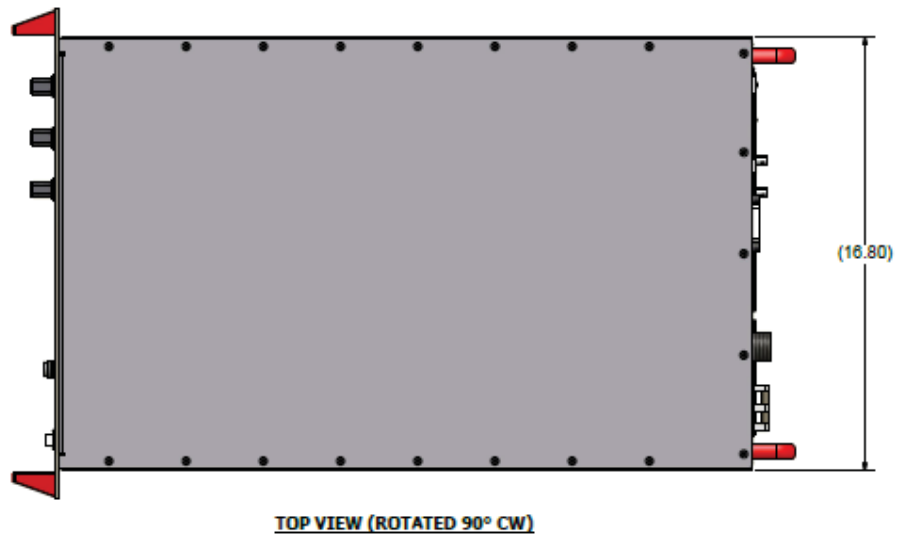
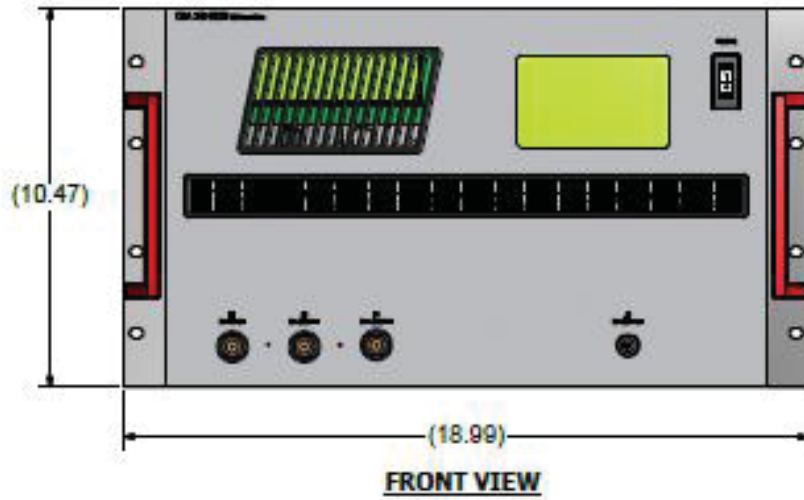

13.4 Fig 4, 10U Front Panel Drawing

This configuration consists of a 7U power amplifier draw & 3U power supply draw



FRONT VIEW



FRONT VIEW
SCALE 1 / 2

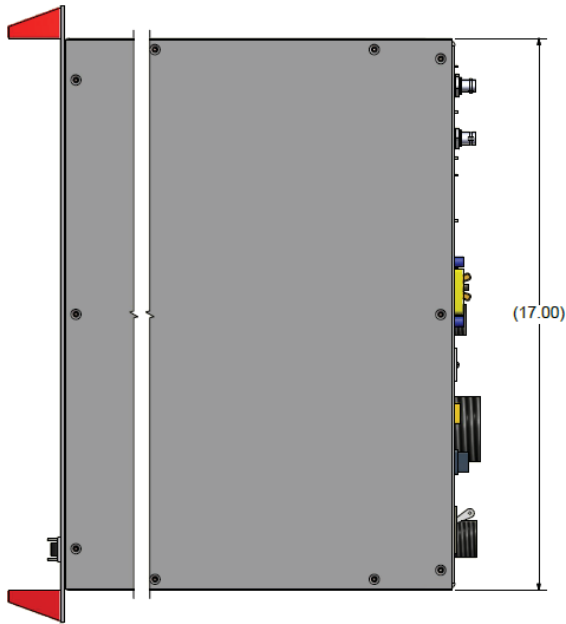

TOP VIEW (ROTATED 90 DEG CW)
SCALE 1 / 2

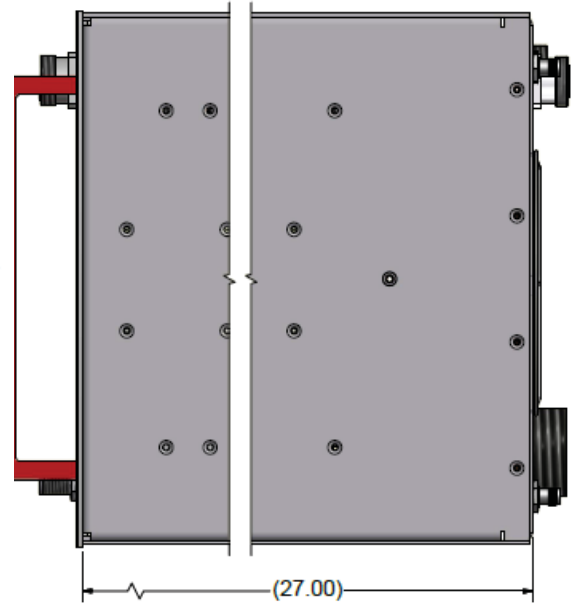

SIDE VIEW

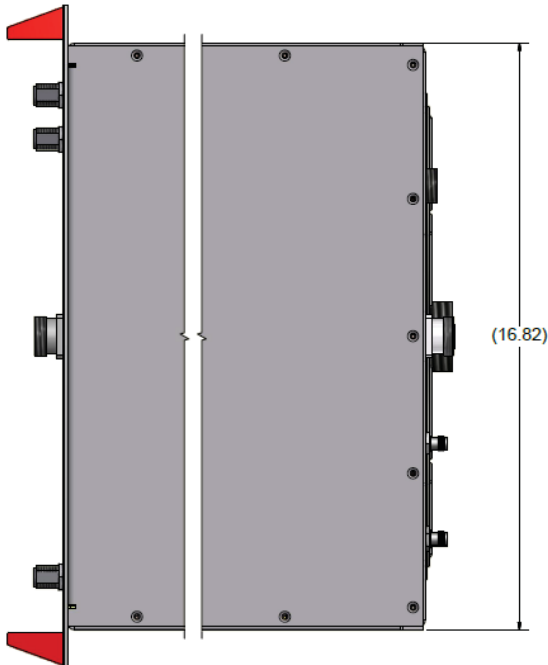

TOP VIEW (ROTATED 90° CW)

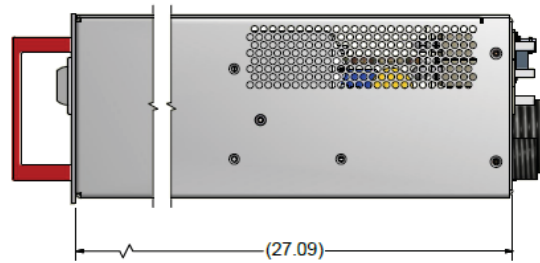

RIGHT SIDE VIEW
SCALE 1 / 2

14 DATASHEET SPECIFICATIONS

<http://www.teseq.co.uk/products/CBA-1G-030B.php>

<http://www.teseq.co.uk/products/CBA-1G-070B.php>

<http://www.teseq.co.uk/products/CBA-1G-150B.php>

<http://www.teseq.co.uk/products/CBA-1G-300B.php>

<http://www.teseq.co.uk/products/CBA-1G-600B.php>

<http://www.teseq.co.uk/products/CBA-1G-1200B.php>

<http://www.teseq.co.uk/products/CBA-3G-050B.php>

<http://www.teseq.co.uk/products/CBA-3G-100B.php>

<http://www.teseq.co.uk/products/CBA-3G-300B.php>

<http://www.teseq.co.uk/products/CBA-3G-500B.php>

<http://www.teseq.co.uk/products/CBA-6G-035C.php>

<http://www.teseq.co.uk/products/CBA-6G-075C.php>

<http://www.teseq.co.uk/products/CBA-6G-040B.php>

<http://www.teseq.co.uk/products/CBA-6G-080B.php>

<http://www.teseq.co.uk/products/CBA-6G-120B.php>