

**INSTRUCTION MANUAL
FOR
SOLAR MODEL 9354-2
TRANSIENT GENERATOR**

Rev. 1.0 November 1, 2007
Rev. 1.1 June 10, 2015

SOLAR ELECTRONICS COMPANY
10866 CHANDLER BOULEVARD
NORTH HOLLYWOOD, CALIFORNIA 91601
Telephone (818) 755-1700 Fax (818) 755-0078 www.solar-emc.com



WARNING

The voltages and waveform pulses produced by this equipment are potentially lethal. Therefore, all safety precautions relevant to this type of high power pulse equipment must be complied with.

READ MANUAL BEFORE OPERATING GENERATOR

**To extend the life of the generator:
Keep its amplitude below 87% except when actively testing;
turn the generator down as soon as testing is complete.**

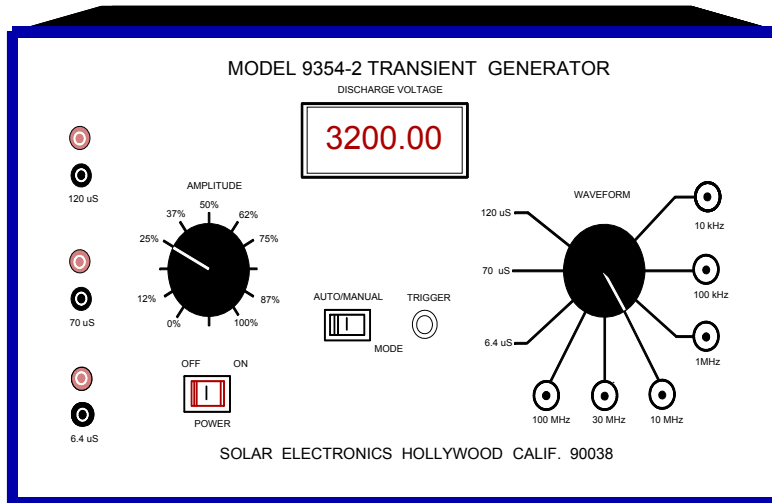

FEATURES

- Panel mounted digital Voltmeter displays reference open circuit discharge voltage.
- Automatic or manual trigger for damped sinusoidal pulses. Manual triggering for double exponential pulses.
- Variable peak output voltage. **VOLTMETER DISPLAY IS A REFERENCE FOR A OPEN CIRCUIT VOLTAGE.**
- An independent circuit for each waveform improves reliability, simplifies maintenance, and allows for customized waveforms and output impedances.
- Solid state switching and RC networks across coils, switches, and relay contacts to reduce arcing, eliminate contact bounce, and increase component life.

Solar Electronics Company

SOLAR MODEL 9354-2 Table of Contents

1.	<u>OPTIONAL ACCESSORIES</u>	1
	Type 6220-4 High Voltage Transformer.	1
	Type 9335-2 Universal Coupling Device.	1
	Type 9410-1 High Voltage Attenuator.	1
	Type 9454-1 High Voltage Attenuator.	1
	Type 9142-1N Injection probe.....	1
	Type 9616-2 High Voltage Surge 70 uS.	1
2.	<u>DESCRIPTION</u>	2
	2.2 Modes of Operation.....	2
	2.3 Peak amplitude	2
	2.4 Polarity	2
	2.5 Output impedances.....	2
	2.6 High Energy Outputs.....	3
	2.7 External Impedance:.....	3
	CAUTION!	3
3.	<u>SPECIFICATIONS (All Verification testing should be done at 50% to prolong life).</u>	4
	DAMPED SINUSOID	4
	DOUBLE EXPONENTIAL	4
	POWER REQUIREMENTS.....	4
	PHYSICAL CHARACTERISTICS	4
4.	<u>APPLICATION</u>	5
	4.1 The six damped sinusoidal waveforms	5
	4.2 Extended limits:	5
	4.3 Double exponential:.....	5
5.	<u>APPLICATION DO 160E SECTION 22</u>	6
	5.1 CATEGORIES AND TEST LEVEL TABLE	6
	5.2 Calibration Setup (100 ohm loop)	6
	5.3 Open Circuit Voltage	7
	5.4 Waveform 5A.....	8
6.	<u>OPERATION</u>	9
	6.1 <u>General</u>	9
	6.2 Type 9335-2 Multi-port Coupling Device Connections.....	9
	6.3 Test Setup.....	9
7.	<u>DELETED</u>	9
8.	<u>THEORY OF OPERATION</u>	9
9.	<u>APPLICATION NOTES</u>	11
	9.1 Direct Injection	11
	9.2 Indirect Injection.....	11
	9.3 Impedance	11
10.	<u>SWR & Discharge voltage:</u>	12

1. OPTIONAL ACCESSORIES

- **Type 6220-4 High Voltage Transformer.** 2:1 step down injection transformer for doubling current (voltage reduce to ~50%). The 70 μS double exponential pulses may require two 6220-4 connected in series for a better impedance match and less saturation. See Isolated 70 μS test setup.
- **Type 9335-2 Universal Coupling Device.** Frequency range of 10 kHz to 10 MHz. Its unique characteristics provides a voltage and current transfer of 1:1, (25 ohm impedance) at port 1, voltage step-down and current step-up of 2:1 (50 ohm impedance) at port 2, and voltage step-up current step-down of 1:1.5 (2.4 ohms impedance) at port 3, or voltage step-up current step-down 1:3 (1.2 ohm impedance) at port 4. (See table below)

Port	Port Z	Turns Ratio	Impedance Ratio
1	25	1:1	1:1
2	50	2:1	4:1
3	2.4	1:1.5	1:2.25
4	1.2	1:3	1:9

- **Type 9410-1 High Voltage Attenuator.** The Type 9410-1 is a special purpose 40 dB 50 / 50 ohm high voltage attenuator. Designed to provide adequate protection for an oscilloscope with a 50 ohm input. It will attenuate very short duration high voltage pulses with relatively low duty cycle. Most scope probes do not provide adequate rise time or attenuation. *(Used in test setups to connect a current probe that has been calibrated in a 50 ohm system, to an oscilloscope with a 50 ohm input impedance)*
- **Type 9454-1 High Voltage Attenuator.** The Type 9454-1 is a special purpose 40 dB 600 /50 ohm attenuator. Designed to simulate an open circuit and provide adequate protection for an oscilloscope with a 50 ohm input. It will attenuate very short duration high voltage pulses with relatively low duty cycle. Most scope probes do not provide adequate rise time or attenuation. *(Used in test setup to establish open circuit waveforms generated by the Model 9354-1 transient pulse generator. As well as connecting a one turn loop through an injection probe and monitoring it with an oscilloscope set to 50 ohm input impedance)*
- **Type 9142-1N Injection probe .** For injecting 1MHz to 100 MHz damped sine wave
- **Type 9616-2 High Voltage Surge 70 μS.**

2. **DESCRIPTION**

- 1 The **Model 9354-2 Transient Generator** provides nine front panel selectable output waveforms, including six damped sinusoidal pulses (10 KHz, 100 KHz, 1 MHz, 10 MHz, 30 MHz, and 100 MHz) and three double exponential pulses (6.4 μ S, 70 μ S, 120 μ S).
- 2 Modes of Operation - The **Model 9354-2** has three modes of operation. A front panel switch selects either **AUTO / MANUAL** single pulse. The waveform selector switch also selects **ACCESSORY OUTPUT** for the external modules (See 9554- () manual for more details on Variable Frequency Modules)
 - A. Automatic Mode - Multiple pulses for the damped sinusoidal pulses well as for the external modules are set internally at the factory for one pulse per second. *The pulse rate can be verified using a counter or Analog Oscilloscope. Monitor the 10 kHz output. Set scope to .2s per/div and 2v per/div using a standard 10X scope probe you will be able to see a pulse on every 5th division.* **Automatic triggering is not provided for the 6.4, 70, or 120 μ S double exponential pulses.** The double exponential pulses are triggered by the manual push-button only.
 - B. Manual Mode - A push button on the front panel provides manual triggering for all nine waveforms Including the Type 9554-() modules through the connecting cable.
- 3 Peak amplitude of the selected output pulse is adjustable from the front panel as a percentage of the charged circuit voltage. The front panel digital voltmeter displays open circuit discharge voltage. The 40 dB high voltage attenuator **Type 9454-1** is used to protect the oscilloscope. (*Note: scope probes do not provide proper attenuation or coupling 50 ohm to the oscilloscope*).
- 4 Polarity - The six damped sinusoidal waveforms outputs use BNC connectors, by reversing the direction of the cable through the window will reverse the polarity of the pulse, while the three double exponential waveform use terminal (banana) jacks can be reversed. The application of the type 6220-4 transformer coupling device and the ability to isolate the pulse from EUT ground is ideal for isolated case injection.
- 5 Output impedances are unique: Although the **Model 9354-2 Transient Generator's** open circuit voltages, and output impedances are unique for each selected waveform, they can be manipulated with resistive networks (see par 9.0) the energy transfer can also *in most cases* be optimized through the different selective windings of the **Type 9335-2 Multi-port Cable Coupling Device**. The unique winding arrangement of this coupling device provides a selection of step-up or step-down impedance ratios with respect to the transient generator source impedance and coupled load impedance. This can provides a better impedance match or power transfer, and higher open circuit voltages into the cable bundle passing through the window of the device. It is the Engineers discretion to select the proper port or resistive network to accomplish the desired result (increase voltage, lower current or to increase current and lower voltage) or to simply match the impedance of the injection probe port to the output impedance or the selected waveform. (Note: Frequency range of the Type 9335-2 is 10 kHz to 10 MHz).

NOTE:

Output parameters vary between the duration or frequency of the selected waveforms, and will be effected by the coupling method and the coupling device employed.

- 6 High Energy Outputs - All output BNC connectors and pairs of binding posts provide for connection of each pulse to the coupling device for series cable injection of up to 3200 volts peak unloaded and 1600 amperes peak loaded. The mating BNC connector and banana plugs are designed and insulated for an open circuit voltage of greater than 4500 volts peak and (2) short circuit currents in excess of 2250 amperes peak. The outer shell of the BNC output connector and the black jack of each output terminal pair are grounded to the front panel and chassis ground. **The generator output ground can be isolated through a Solar Type 9335-2 coupling device, and for 6.4 μ S a audio isolation transformer Solar Type 6220-4.**

- 7 External Impedance: Because of the generator's wide range of parameters and various calibration techniques specified by the different requirements, each output or waveform has been designed to meet the more stringent of these requirements, provided the appropriate EXTERNAL impedance network is used (see application NOTES)

CAUTION!

TURN SELECTOR SWITCH TO 120 μ S POSITION *than* turn AMPLITUDE KNOB TO ZERO, AND PULSE THE 120 μ S TO DISCHARGE ALL CAPACITORS.

3. SPECIFICATIONS

DAMPED SINUSOID

	10 KHz	
Open Circuit Voltage		30.0 V
Source Impedance.....		< 0.25 Ω
	100 KHz	
Open Circuit Voltage		300.0 V
Source Impedance.....		< 3.8 Ω
	1 MHz	
Open Circuit Voltage		3200.0 V
Source Impedance.....		<28.0 Ω
	10 MHz	
Open Circuit Voltage		3200.0 V
Source Impedance.....		<39.0 Ω
	30 MHz	
Open Circuit Voltage		1500.0 V
Source Impedance.....		<50.0 Ω
	100 MHz	
Open Circuit Voltage		600.0 V
Source Impedance.....		<50.0 Ω

DOUBLE EXPONENTIAL

	6.4 μ S	
Rise Time.....		100 nS
Open Circuit Voltage		1600 V
Source Impedance.....		< 2.0 Ω
	70.0 μ S	
Rise Time.....		6.4 μ S
Open Circuit Voltage		1600 V
Source Impedance.....		< 2.0 Ω
	120.0 μ S	
Rise Time.....		40 μ S
Open Circuit Voltage		750 V
Source Impedance.....		1.0 Ω

POWER REQUIREMENTS

Power Source	115 V unit: 60 Hz, or 230 V unit: 50 Hz
Power Consumption	50 Watts
Power Line Fuses.....	115 V unit: 2 @ 3A Slow-Blow, or 230 V unit: 2 @ 1.5A Slow-Blow

PHYSICAL CHARACTERISTICS

Net Weight	55 Lbs. (25 Kg)
Shipping Weight.....	58 Lbs. (26.3 Kg)
Height	9.12 In. (222 mm)
Width	17.12 In. (435 mm)
Depth.....	13.50 In. (343 mm)

4.APPLICATION

- 1 The six damped sinusoidal waveforms meet the requirements of **MIL-STD-461E** and **MIL-STD-461D**, test method **CS116**, when applied in accordance with the corresponding test method of **MIL-STD-461E** and **MIL-STD-462D**. These same waveforms are applicable to the requirements of **MIL-STD-461C**, **CS10 & CS11** when applied with the test method of **MIL-STD-462**, **Notice 5**.
- 2 Extended limits: Two of the six damped sinusoidal waveforms (1 MHz and 10 MHz) have their limits extended to an open circuit voltage of 3200 volts peak to meet the requirements of **DO-160D**, **Section 22**, **Table 22-2**,.
- 3 Double exponential: The double exponential pulses were specifically designed to meet the requirements of **DO-160C**, **Section 22**, (See table below).

5. **APPLICATION DO 160C, SECTION 22**

5.1 **CATEGORIES AND TEST LEVEL TABLE**

CATEGORY	TEST LEVEL					
	Long Wave 70 uS Direct Injection		Short Wave 6.4 uS Probe Injection		1 MHz & 10 MHz Sinusoidal wave	
	Vp	Ip	Vp	Ip	Vp	Ip
J	125	25	125	25	250	10
K	300	60	300	60	600	24
L	750	150	750	150	1500	60
M	1600	320	1600	320	3200	128

Vp= Peak open circuit Voltage (V)

Ip= Peak test limit Current (A)

5.2 **Calibration Setup (100 ohm loop)**

Equipment used

Solar Model 9354-2 Transient Pulse Generator.

Type 9357-1 Calibration Fixture.

Type 9335-2 Multiple Coupling Injection Probe.

Type 9841-1 High voltage 50 ohm termination.

Type 9410-1 High voltage Attenuator 50/50.

For frequencies above 1 MHz.

Type 9125-1 Calibration Fixture.

Type 9142-1N Injection Probe.

10 KHz Damped sinusoidal into Type 9335-2 port 2	% of Amplitude to active I max 70 %	I max 0.1 amp = 5 volts	50 ohm coaxial cable ~ 6 ft
100 KHz into Type 9335-2 port 2	% of Amplitude to active I max 70 %	I max 1 amps = 50 volts	50 ohm coaxial cable ~ 6 ft
1 MHz into Type 9335-2 port 2	% of Amplitude to active I max 60 %	I max 10 amps = 500 volts	50 ohm coaxial cable ~ 6 ft

10 MHz Damped sinusoidal into 9142-1N	% of Amplitude to active I max 70 %	I max 10 amps = 500 volts	50 ohm coaxial cable ~ 6 ft
30 MHz into 9142-1N	% of Amplitude to active I max 70 %	I max 10 amps = 500 volts	93 ohm coaxial cable ~ 6 ft
100 MHz into 9142-1N	% of Amplitude to active I max 60 %	I max 3 amps = 150 volts	50 ohm coaxial cable ~12 ft

5.3 Open Circuit Voltage

Additional Equipment used

Type 9454-1 High voltage Attenuator 600/50. The 600 ohm input of the 9454-1 attenuator connected to the Model 9354-1 is ideal for simulating open circuit testing.

BNC to banana adaptor.

1 MHz into Type 9454-1 attenuator	Amplitude to achieve open circuit voltage ~ 87 %	3200 volts	
10 MHz into Type 9454-1 attenuator	Amplitude to achieve open circuit voltage ~ 87 %	3200 volts	

6.4 μ S into Type 9454-1 attenuator	Amplitude to achieve open circuit voltage ~ 87 %	1600 volts	
70 μ S into Type 9454-1 attenuator	Amplitude to achieve open circuit voltage ~ 87 %	1600 volts	
500 μ S into Type 9454-1 attenuator	Amplitude to achieve open circuit voltage ~ 87 %	1600 volts	

IMPORTANT NOTE

LIMITATIONS of newer Digital Oscilloscope: DIGITAL Oscilloscopes that have a maximum 1 volt per division with a 50 ohm input cannot view the 3200 volt open circuit damped sinusoidal, or the 1600

volt double exponential waveforms.

SOLUTION: By using the 1 M input and a 50 ohm termination at the scope gives you the 50 ohm input required by the MIL-STD-461. This allows you to have 10 volts per division X 100 will give you 1000 volts per division when using the type 9454-1 or the 9410-1 40 dB Attenuator.

NOTE

As specified in **para 22-2 of RTCA DO-160D** category specification.

Category J is intended for equipment and interconnect wiring that will be installed in a partially protected environment such as an enclosed avionics bay in an all-metallic aircraft.

Category K is intended for equipment and interconnect wiring that will be installed in a moderate environment such as the more electromagnetically open area (e.g., cockpit) of an aircraft composed principally of metal.

Category L & M is intended for equipment and interconnect wiring that will be installed in severe electromagnetic environments. Such levels might be found in all-composite aircraft or other exposed area in metallic aircraft.

Category X No test required.

6. **OPERATION**

- 1 **General** Each of the nine pulse provide adequate power to perform pin injection, or Air force alternative method of injecting high frequency pulses, isolated case injection. Type 9335-2 coupling device is adequate for frequencies from 10 kHz to 1 MHz, and can be applied to either D.C. or A.C. power lines, ground lines or control lines, interconnecting lines or interface cables that have no more than 500 volts impressed upon them or 50 amperes R.M.S. flowing through them.

NOTE:

*Turning off the **Model 9354-2** power switch will slowly discharges the main pulse storage capacitors. Pulsing in the 120 μ S long wave possession will discharge the capacitors (faster).*

- 2 **Type 9335-2 Multi-port Coupling Device Connections** - Connect the coaxial cable to the selected port of the Type 9335-2 (you may find that one port may be better suited over the other ports, depending on the frequency / impedance of the generator in relation to the impedance of the line under test).

Select the lines to be evaluated and place them through the window of the coupling device. Close the device, apply power, and proceed with the test.

- 3 **Test Setup** - The general test setup is shown in Figure CS116-1.

The **Model 9354-2** case must be grounded at all times.

7. **DELETED**

8. **THEORY OF OPERATION**

- 1 When A.C. power is applied through the power switch (S1) the **Model 9354-2** three separate power supplies go into operation. A variac controlled, 500 milliampere series limited, full wave double (twin) doubler, high voltage power supply provides four distinct output voltages to continually charge the individual circuit capacitors without the heat loss normally associated with a resistive divider. Each segment of each voltage doubler produces a maximum of 1250 volts D.C. for a series total of 5500 volts D.C. to charge the capacitors of all nine pulse circuits. There is a 150 milliamperes, full wave, 30 volt D.C. power supply for driving electro mechanical switches and pulse networks to trigger the gates of two SCR. switches. There is also a 100 milliamperes, 7 volts full wave D.C. power supply for the digital voltmeter display and the automatic firing circuit.
- 2 The 10 KHz and the 100 KHz damped sinusoidal circuits use SCR. switches with gate isolation transformers and pulse drive to discharge the circuit capacitor into an inductor

with the appropriate conjugate impedance at the resonant frequency to provide the required damping factor when loaded. The theory of operation for the 1 MHz, 10 MHz, 30 MHz, and 100 MHz damped sinusoid is the same except the switches to discharge the circuit capacitors are electro mechanical and require 26 volt D.C. drive to operate.

- 3 The three double exponential circuits also use multiple SCR switches to discharge the circuit capacitors. However, the capacitors are discharged into a resistive network to ensure a proper waveform and maintain required duration tolerance when matched.
- 4 As one example of the theory of operation, the 1 MHz damped sinusoidal circuit, has its discharge capacitor (C5) charged from five series 2 watt resistors (R3, R4, R5, R6, and R7). A voltage multiplier made up of 10 series 1 watt resistors (R8 through R18) is connected from the 1 MHz discharge capacitor (C5) through the switch deck "C" wiper arm contact #12 and switch contact #3 of the port activation switch (S4) to a factory selected 1 watt resistor (R9) connected to the voltage multiplier resistor (R8) that provides a scaled output of the charge voltage to the voltmeter (VM1) input for readout on the digital display (DD1). In the manual or single pulse mode, depressing the front panel push button closes contacts #1 and #2 of micro switch (S3) that is connected through closed contacts #2 to #3 and #5 to #6 of the automatic/manual DPDT switch (S2), switch deck "B" wiper arm contact #12 and switch contact #3, switch deck "A" wiper arm contact #12 and switch contact #3 of the port activation switch (S4) to the 30 volt D.C. power supply, which drives the module relay switch (RS5) that connects the tapped inductor (L3) across the charged capacitor (C5) to produce the 1MHz damped sinusoid discharge. The inductor tap is connected to the center pin of modules' front panel connector (BN3) to provide the 1 MHz output with a damping factor of 5 when loaded with 25 ohms.
- 5 For another example of the theory of operation, the 70 μ S double exponential circuit, has its discharge capacitor (C10) charged from two series, current limiting, 50 watt resistors (R1 and R2) of the high voltage power supply. The voltage multiplier discussed previously is connected from the 70 μ S discharge capacitor (C10) through deck "C" wiper arm contact #12 and switch contact #eight of the port activation switch (S4) to a factory selected one watt resistor (R14) connected to the voltage multiplier resistor (R8) to provide the scaled output of the charge voltage to the voltmeter (VM1) for readout on the digital display (DD1). In the automatic or multipulse mode, contacts #1 and #2 of the driven mercury wetted switch (MWS1) are connected through closed contacts #1 to #2 and #4 to #5 of the DPDT automatic/manual DPDT switch (S2), switch deck "B" wiper arm contact #12 and switch contact #8, switch "A" wiper arm contact #12 and switch #8 of the port activation switch (S4) through the resistor (R22) capacitor (C19) relay drive network to the 30 volt D.C. power supply, which drives the module relay switch (RS10) that connects a resistor network (R35 and R36) across the charged capacitor (C10) to produce the 70 μ S double exponential discharge. The junction between R35 and R36 is connected to the positive terminal of the modules front panel jacks to provide the 70 μ S pulse duration when loaded with 2 ohms.

9.

APPLICATION NOTES

- 1 **Direct Injection** - Generally direct injection is part of a subsystem/equipment conducted susceptibility or vulnerability testing and is applied between an isolated equipment case and ground or from a connector pin to the connector shell. In most cases the required direct injection level is lower than the maximum capability of the generator. Therefore, a resistive network can be developed externally to adjust the output impedance and provide the required open circuit voltage and/or peak circuit current specified by the designated test procedure.

- 2 **Indirect Injection** - (Consider isolated case injection) The Type 9335-2 Multi-port coupling Device along with other injection probes are inductive coupling devices used for system susceptibility testing and applied to the subsystem/equipment interconnecting cables. The inductive coupling device (transformer) provides more latitude in the development of the required output impedance. Consider the previous example of the generator port 1 with the 25 ohm output impedance. The 2:1 step down port 2 of the Type 9335-2 or similar type of two turn injection probes (primary) could be (secondary) of about 6.25 ohms. As stated in the example, resistors may be used to adjust the output impedance to 5 ohms. Also a special injection probe with segmented cores could be built to produce the 5 ohm output impedance without resistors.

- 3 **Impedance** - There may be occasions when the existing output impedance of the Transient Generator may be inappropriate for a specific test procedure of the specification requirement. Since the generator impedances are a function of frequency and waveform; no single output impedance could be selected without sacrificing performance. However, because of the available power, many other impedances at different open circuit voltages and peak circuit currents may be developed external to the generator (with the proper resistive network or transformer).

If for example the generated open circuit voltage is 3200 volts and peak circuit current is 128 amps, the output impedance would be 25 ohms. By externally adding a series 22 ohm resistor from the output connector center conductor to a shunt 5.6 ohms that is connected to the connector ground, the open circuit voltage at the junction of the 22 ohm and 5.6 ohm is 340 volts and the peak circuit current is 68 amps. This results in a output impedance of 5 ohms.

10. SWR & Discharge voltage:

The Model 9354-2 Displayed discharge voltage is in reference to the open circuit discharge voltage. This will coincide with an open circuit voltage onto a **SOLAR 9454-1 Attenuator**, 600 ohm input to 50 ohm output, with a calibrated attenuation of 40 dB.

The output impedance of the generator at each port is dependent on the waveform and/or frequency of the transient selected. Since the 600 ohm network representing an open circuit does not match the output impedance of the generator and the standing wave ratio (SWR) is higher; It is important to keep the unmatched portion of the output circuit as short as possible (less than six inches), especially at the higher frequencies.

If an attempt is made to measure the open circuit voltage and waveform above 1 MHz with an unmatched 50 ohm cable, which is longer than 12 inches at 100 MHz (1/10 wavelength), into a high impedance (1 megohm) spectrum analyzer, the SWR will distort the output waveform and cause the measured output voltage and waveform to be significantly different than that of the actual waveform.

APPENDIX

Investigation of Current Waveform Distortion Through Magnetic Coupling Devices into Short Circuits.

Background

Several customers, engineers, and technicians have expressed difficulty in producing the DO-160, Section 22, Waveform 1, the 70 μS double exponential current waveform from either Waveform 2, the 6.4 us voltage waveform, or Waveform 4, the 70 μS voltage waveform of the Transient Pulse Generator through the Multi-port Coupling Device (which was only designed for the coupling of the damped sine-wave and generators with different source impedances) into a short circuit or (0.1 Ω non-inductive resistor).

Although it is written in Section 22 under Waveform 2 that *ideally* the voltage waveform of Waveform 2 would produce the short circuit current waveform of Waveform 1 through an inductive transformer; no special coupling device has yet been identified that could demonstrate the concept. Therefore, until the unique device becomes available we will try to explain the problems and provide some solutions.

Identifying the Problems

The first thing was to duplicate the Test Setup, reproduce the waveform distortion, and try to identify the source of the problem. After duplicating the Test Setup, the Transient Pulse Generator output was measured to verify that it provided the required 70 μS open circuit voltage of 1600 Vpk and when matched with a 2 Ω load the voltage output dropped to approximately half or 800 Vpk. When the generator was connected to Port 2 (2:1) of the Multi-port Coupling Device in a calibration fixture and the output voltage waveform measured across one of the fixture's two 50 Ω terminations, the pulse width was reduced (24 μS), and the unsaturated voltage was limited (30 Vpk). This was believed to be from insufficient core cross section, inductive reactance, and resistive loading of the primary. When the fixture's terminations were replaced with shorts (0.1 & 0.01 Ω) and the waveform measured with a clamp-on current probe, the waveform was distorted even though the pulse width was slightly wider (30 μS). The distortion and increase in pulse width was attributed to the Multi-port Coupling Device's increase in secondary loading, which increased the bandwidth, circuit current, and premature core saturation. However, it was later determined that both the Multi-port Coupling Device (injection probe) and the current probe (reception probe) had similar low frequencies deficiencies, which made the problem appear even worse.

Providing a Solution

Since the voltage and the current waveforms must be the same across a resistor; to eliminate the distortion from the reception probe and help identify the major contributor(s) to the problem, a non-inductive 0.1 Ω resistor was connected in series with the calibration loop and the voltage waveform measured across the resistor using a calibrated scope. The waveform was plotted and the peak current

calculated using Ohms law. After verifying the waveform and current, a Spike Receptor Probe, Type 7541-1 was identified with a lower cutoff frequency (1 kHz). This receptor probe was then used to re-measure and verify that the current waveform was the same as the voltage waveform measured across the 0.1Ω resistor.

Although the resulting short circuit current waveform was better than originally measured, the coupling device or injection probe was still saturated and limited at the low frequency end of the spectrum. To further improve the fidelity of the current waveform, the level of the pulse generator had to be reduced and the injection probe's low frequency performance increased. This meant either adding more primary turns and/or magnetic core material to increase the level of saturation, lower the cutoff frequency, and increase the injection probe's impedance, or reducing the pulse amplitude and driving the injection probe from a lower source impedance. In an effort to use existing equipment, the second proposed solution was selected. This was accomplished by connecting the $70\ \mu\text{S}$ output of the Model 9354-2 Transient Pulse Generator into the primary of a Type 6220-4 Audio Isolation Transformer (2:1 step down) and connecting the secondary into Port 2 of the Type 9335-2 Multi-port Coupling Device (2:1 step down). However, it should be noted that this test configuration is limited to a short circuit current of about $120\ \text{I}_{\text{pk}}$ with a pulse width of $70\ \mu\text{s}$, and a matched circuit current of $30\ \text{I}_{\text{pk}}$ with a pulse width of $35\ \mu\text{s}$ and a voltage output of $60\ \text{V}_{\text{pk}}$.

Test Results

During the investigation several other test configurations were evaluated using existing as well as some newly developed equipment. The configuration of each test setup is diagrammed and the equipment involved is identified or described in Configuration 1 through 3, and the plotted short circuit current waveforms are shown in Figures 1 through 5.

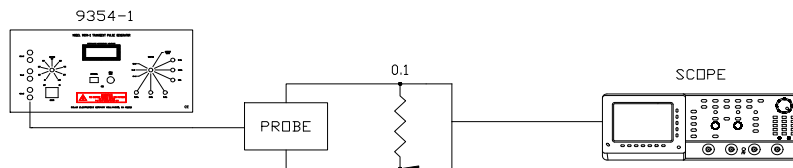

Test Configuration 1
Standard setup

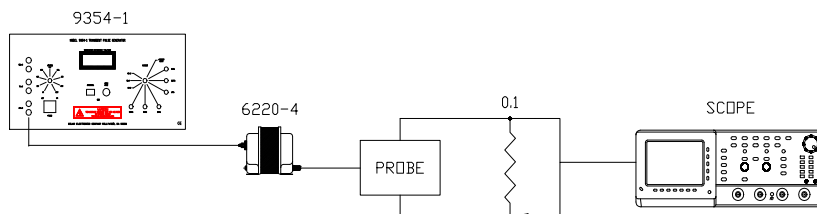

Test Configuration 2
Use of Type 6220-4

Figure 1, 6.4 μ S Short Circuit Current Waveform, Test Configuration 1.

6.4 μ S pulse into a Type 9127-1 Injection probe.

Measuring the short circuit current across a Non-inductive 0.1 ohm resistor. 4000 A?

NOTE

This would be an error because of the inductive reactance, A curve measuring the reactance at 1 MHz (1 μ S) would measure 1 ohm so the correct current would be 400 volts divided by 1 ohm or 400 A.

Figure 2, 6.4 μ S Short Circuit Current Waveform, Test Configuration 1.

6.4 μ S pulse into port 2 (2:1) of Type 9335-2 Injection probe. Measuring the short circuit current across a Non-inductive 0.1 ohm resistor. 4000 A?

Figure 3, 70 μ S Short Circuit Current Waveform, Test Configuration 2.

70 μ S into a Type 6220-4 Isolation transformer into port 2 of the Type 9335-2 Injection probe. Measuring the short circuit current across a Non-inductive 0.1 ohm resistor. 100 A.

Figure 4, Short Circuit Current Waveform, Test Configuration 1.

70 μ S into two Type 9335-2 injection probes with 4 turns for the primary. Measuring the short circuit current across a Non-inductive .05 ohm resistor. 400 A. (this seems to be equivalent to Test Configuration 2).

Figure 5, Short Circuit Current Waveform, Test Configuration 2.

70 μ S into two Type 6220-4 into the 4:1 port of the Type 9616-1 injection probes. Measuring the short circuit current across a Non-inductive .1 ohm resistor. 800 A.

Conclusions:

If the full capabilities of the Model 9354-2 Transient Pulse Generator or other pulse generators that have selectable waveforms, different source and load impedances, and various voltage and current outputs are to be realized; then either several differently designed and sized coupling devices, or a single larger sized coupling device designed with several selectable configurations would be required. Presently there is no single coupling device in our inventory that can meet all the pulse requirements.

Application note:

Waveform 5A (40 μ S x 120 μ S) +/-20%

DO160 SECTION 22 single stroke

Pin injection up to Level 4

Cable bundle (ground injection) up to Level 3.

Pin injection-

Open circuit voltage is measured using a x100 voltage probe. Verify the waveform meets the requirement for time to crest and duration. The generator source impedance is checked by installing a 1 ohm resistor across the output of the generator and verifying that the voltage drops to half the open circuit voltage +/- 10%.

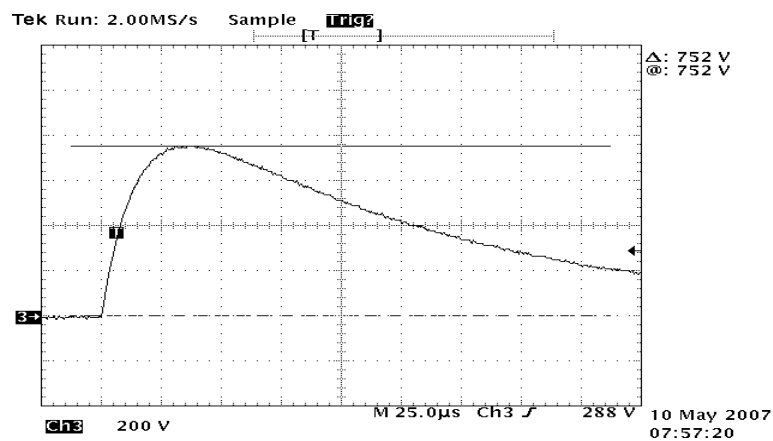

Open circuit voltage

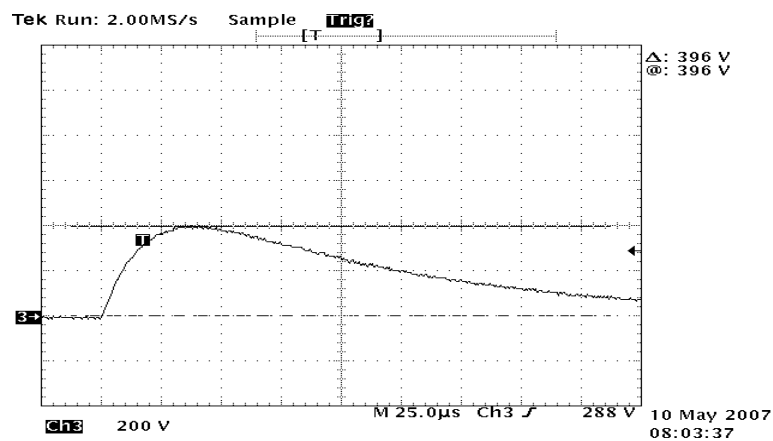

Generator source impedance verification

Ground injection-

The output of the generator is connected to the primary of a Solar Type 6220-2 audio isolation transformer.

The procedure for verifying generator performance is as follows-

Short the secondary of the 6220-2 audio isolation transformer. Using the Solar type 7541-1 spike receptor probe (20 dB correction factor) and a 9410-1 high voltage attenuator (40 dB correction factor), measure the waveform and verify it meets the requirement for time to crest and duration.

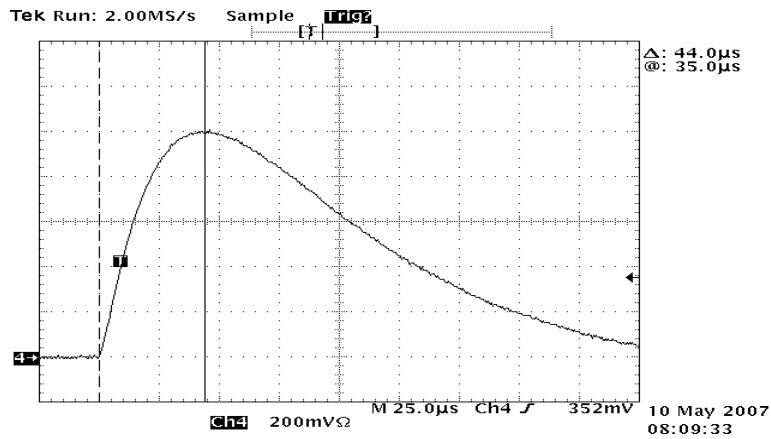

Calibration loop short

SOLAR SCHEMATIC Model 9354-1 Pulse Generator

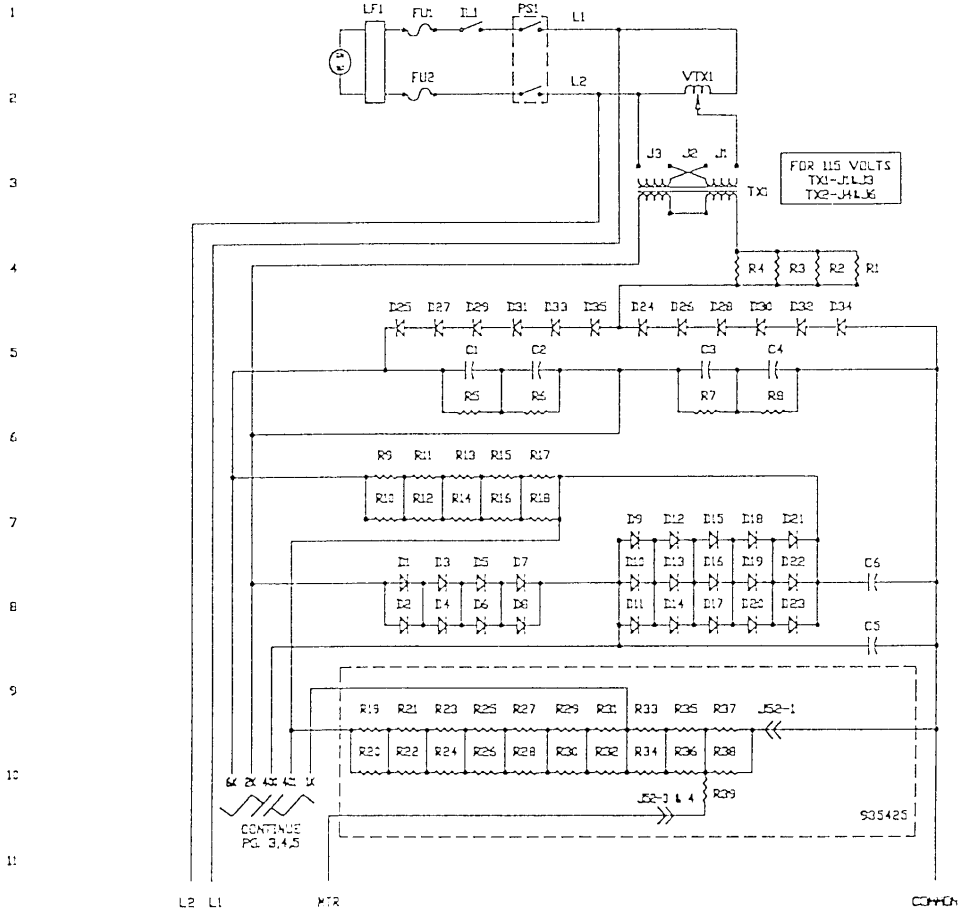

SOLAR SCHEMATIC Model 9354-1 Pulse Generator

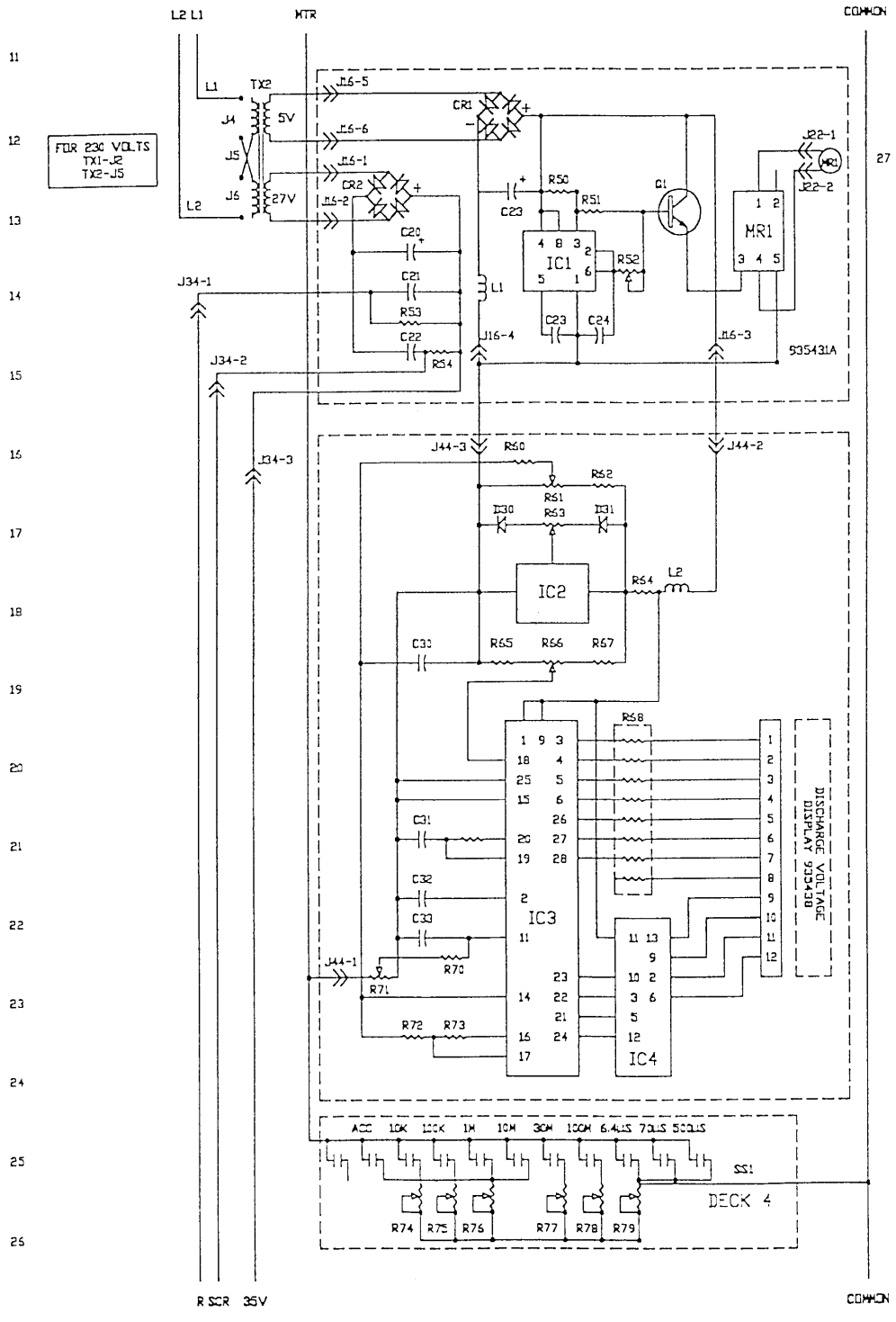

SOLAR SCHEMATIC Model 9354-1 Pulse Generator

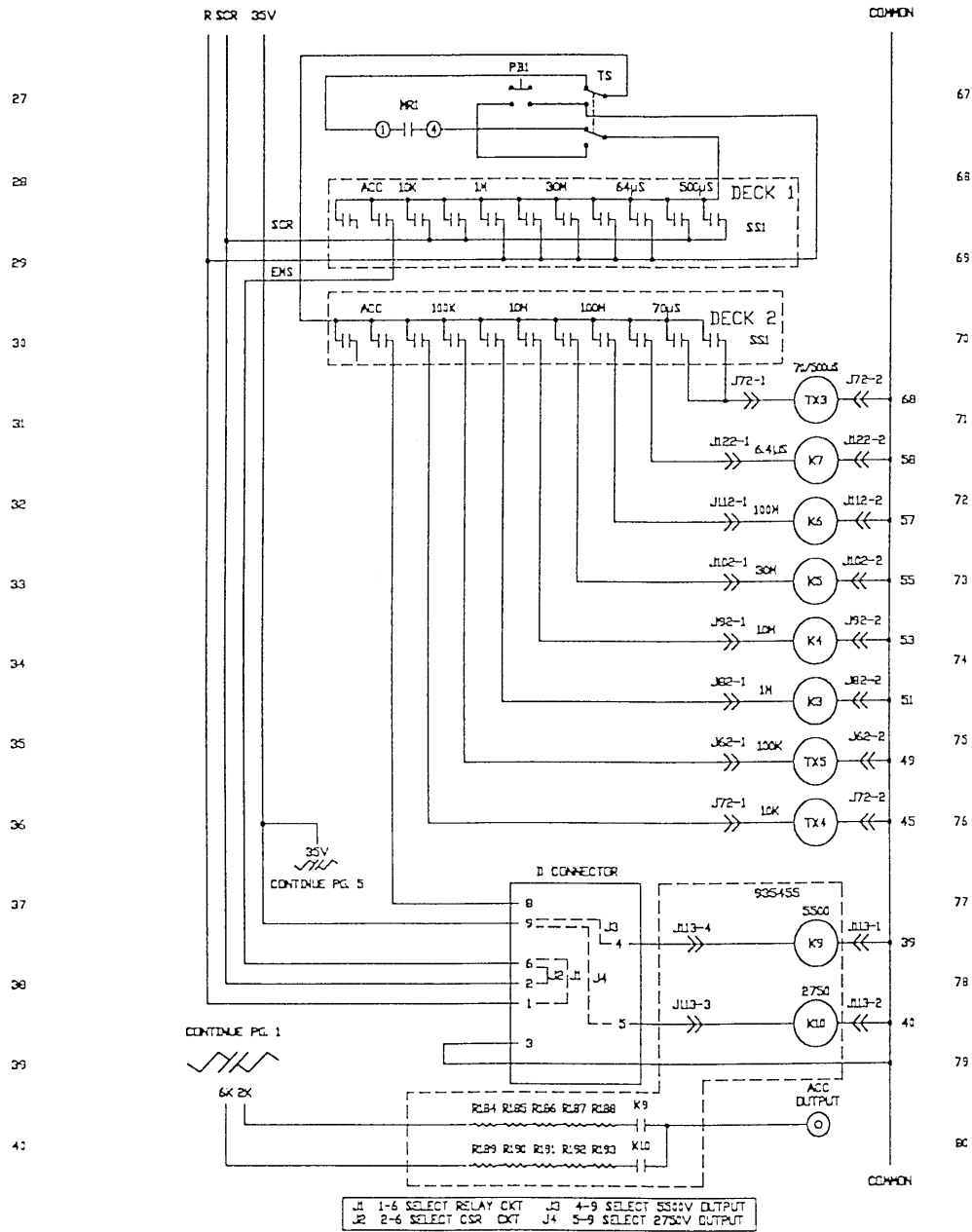

SOLAR SCHEMATIC Model 9354-1 Pulse Generator

