

P16, P16 AVC, P20

Tube-to-tube-sheet orbital weld heads

Our P series is characterized by special design features intended to ensure easy handling combined with a high level of economy and functionality.

With extreme precision, these tube-to-tube-sheet orbital weld heads will produce several thousand weld seams at constant quality.



Tube-to-tube-welding on large-scale heat exchanger with highest precision and efficiency

Easy handling and a maximum of functionality

Liquid-cooled weld head up to 30° freely pivotable

With this TIG weld heads, it is no longer a problem to weld tubes to tubesheets with the highest of accuracy and consistent quality

Its liquid cooling is fed right to the TIG burner head, which ensures more precise working and consistent quality of the welding process, as well as extending the power-on time. The burner head can be pivoted freely by up to 30° - this function is valuable, for instance, on tubes that are entering tubesheets at an angle or in restricted spaces.

ADDITIONAL FEATURES:

- Completely liquid-cooled weld head housing (P16/P16 AVC only)
- Burner head can be pivoted freely by up to 30° (reduced diameter range)
- Weld seam geometries: Recessed, flush and protruded tubes
- Current transmission via multi-plate clutch
- Gas/liquid transmission via rotating coupling
- Three-point mounting made of stainless steel
- Manually electrode positioning Stroke +/- 5 mm
- Special burner heads adaptable, e.g. for box-header welding (P16, P16 AVC only) or for IBW/ internal bore welding (with/without cold wire)
- Positioning on the tube to be welded is by means of a centering tool that is placed on a retaining arbor (available option)

- The weld heads with integrated cold wire unit additionally include a retaining mechanism for Ø 100 mm/1 kg (3.937"/2.2 lbs) standard wire reels
- Revolving wire feed on the rotational axis of the TIG burner prevents the additional wire from twisting when it exits the wire nozzle (only P16/P16 AVC)
- Three-point mounting included
- 7.5 m (24.6 ft) hose package and tool set included

ADDITIONAL FEATURES P16 AVC:

- Equipped with an electric arc voltage control (AVC) - only applicable in combination with the orbital welding power supply ORBITAT 300 CA AVC/OSC



P16



P16 AVC



P20

APPLICATION RANGE		P16	P16 AVC	P20
Code	with cold wire unit	831 000 001	831 000 002	832 000 002
	without cold wire unit	831 000 003	-	832 000 001
From tube ID to tube OD		10 - 78 mm* 0.394" - 3.071"*	12 - 100 mm* 0.470" - 3.937"*	10 - 70 mm* 0.394" - 2.756"*
TECHNICAL DATA		P16	P16 AVC	P20
Weight of machine with hose package	with cold wire unit	17.5 kg 38.6 lbs	18.3 kg 40.3 lbs	12.75 kg 28.1 lbs
	without cold wire unit	16.2 kg 35.7 lbs	-	11.5 kg 25.4 lbs
Weight of cold wire unit		1.0 kg 2.2 lbs	1.0 kg 2.2 lbs	1.0 kg 2.2 lbs
Cold wire unit Ø		1.0 kg 2.2 lbs	1.0 kg 2.2 lbs	100 mm 3.937"
Hose package length		7.5 m 24.6 ft	7.5 m 24.6 ft	7.5 m 24.6 ft

SCOPE OF DELIVERY	
Including:	<ul style="list-style-type: none"> • 1 Tube-to-tube-sheet orbital weld head P16, P16 AVC or P20 • 1 Three-point mount • 1 Durable storage and shipping case • 1 Tool set • 1 Operating instructions and spare parts list
Suitable accessories (available option):	<ul style="list-style-type: none"> • Centering tools and retaining arbors • Special torches (e.g. for boxheader or internal bore welding (IBW)) • Quick-change adapter torch equipment • Cold wire feed units (retrofit kits) • Spring balancers • Closed gas covers • Front cages • ESG tungsten grinders • Earth cable • Hose package extensions • Pressure regulator • WS2 tungsten electrodes

DIMENSIONS	P16	P16 AVC	P20
Dimension "A"	182.97 mm 7.204"	187.05 mm 7.364"	175.00 mm 6.890"
Dimension "B"	427.25 mm 16.821"	427.25 mm 16.821"	400.00 mm 15.748"
Dimension "C"	344.00 mm 13.543"	344.00 mm 13.543"	331.40 mm 13.047"
Dimension "D"	80.00 mm 3.150"	80.00 mm 3.150"	72.00 mm 2.835"
Dimension "E"	95.50 mm 3.760"	95.50 mm 3.760"	87.50 mm 3.445"
Dimension "F"	466.00 mm 18.346"	582.00 mm 22.913"	461.16 mm 18.156"

* Smaller and larger dimensions on request.

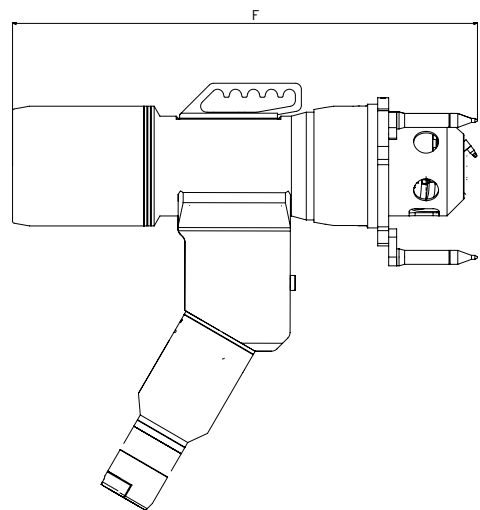
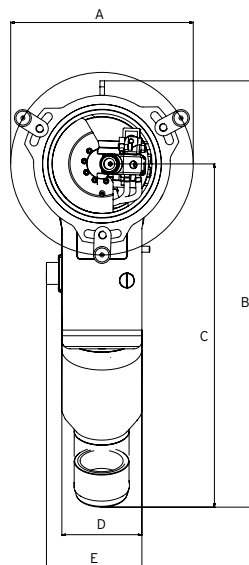

The technical data are not binding. They are not warranted characteristics and are subject to change.

Tube-to-tube-sheet orbital weld heads

P16, P16 AVC, P20

Features, application range, technical data and scope of delivery, see page 63.

The following accessories are essentially required for operating the tube-to-tube-sheet orbital weld heads and must be ordered separately:

- Retaining arbors and centering tools (see from page 68)
- Earth cable (see from page 82)

ARTICLE	CODE	WEIGHT OF MACHINE KG*	DISPATCH WEIGHT KG
Orbital weld head P16 with cold wire unit	831 000 001	17.500	26.500
Orbital weld head P16 without cold wire unit	831 000 003	16.200	25.100
Orbital weld head P16 AVC with cold wire unit	831 000 002	18.300	27.300
Orbital weld head P20 with cold wire unit	832 000 002	12.750	20.400
Orbital weld head P20 without cold wire unit	832 000 001	11.500	20.350

* Machine weight including hose package

Suitable accessories (available option):

- Centering tools and retaining arbors, see page 68
- Earth cable, see page 82
- Special torches (e.g. for boxheader or internal bore welding (IBW)), see page 66
- Quick-change adapter torch equipment, see page 66
- Spring balancers, see page 67
- Closed gas covers, see page 67
- Front cages, see page 67
- Torch and cold wire consumables, see page 85
- Remote control, see page 17



P16



P16 AVC



P20

TUBE-TO-TUBE-SHEET ORBITAL WELD HEADS



Accessories for tube-to-tube-sheet orbital weld heads

Special torches

Special torches for the following welding positions are available on request:

Boxheader welding torch



Internal bore welding torch (IBW):
For welding of recessed tubes and back sheet applications

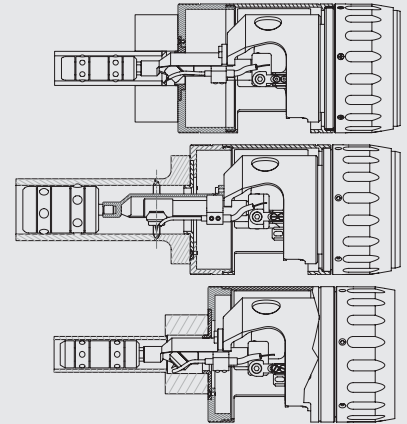

ARTICLE	CODE	KG
Boxheader welding torch	on request	
Internal bore welding torch (IBW)	on request	

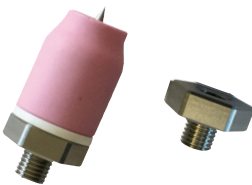

Quick-change adapter torch equipment

Quick-change adapter torch equipment

Through this quick-change adapter the torch equipment of the tube-to-tube-sheet orbital weld heads P16, P16 AVC and P20, can be set up comfortably and exchanged faster, irrespective of the torch.

ARTICLE	CODE	KG
Quick-change adapter torch equipment	831 050 019	0.012

Cold wire feed units "KD" (retrofit kits)

For upgrading tube-to-tube-sheet orbital weld heads without cold wire unit. Including wire reel retainer for Ø 100 mm/1 kg (3.937"/2.2 lbs) standard wire reels.

ARTICLE	CODE	KG
Cold wire feed P16 / P16 AVC	831 001 116	1.500
Cold wire feed P20	832 050 030	1.500

TUBE-TO-TUBE-SHEET ORBITAL WELD HEADS

Spring balancers

For load-free suspension of tube-to-tube-sheet orbital weld heads.

ARTICLE	TENSILE LOAD MAX. [KG]	CODE	KG
Spring balancer for P16	10 - 14	832 030 002	3.800
Spring balancer for P20	6 - 8	832 020 001	2.370



Spring balancers

Closed gas covers

For welding titanium tubes under a full gas cover.

ARTICLE	CODE	KG
Closed gas cover for P16	831 001 101	1.300
Closed gas cover for P20	832 020 002	0.800



Closed gas cover

Front cages

With bearing ring.
Ideal for welding of flush and recessed tubes.

ARTICLE	CODE	KG
Front cage for P16	831 050 001	0.360
Front cage for P20	832 050 001	0.360



Front cage

TUBE-TO-TUBE-SHEET ORBITAL WELD HEADS



Centering tools



Retaining arbor

Centering tools and retaining arbors

The tube diameter is required to select the correct centering tool. Smaller and larger dimensions on request.

When ordering, please consider the correct centering tool/retaining arbor combination.

ARTICLE	GROUP	CARTRIDGE SIZE/NO.	PIPE ID* [MM]	PIPE ID* [INCH]	CODE		KG
Retaining arbor for centering tools for group A					832 020 003		0.060
Centering tool	A	1	10.0 - 10.5	0.394 - 0.413	832 020 004		0.040
Centering tool	A	2	10.5 - 11.0	0.413 - 0.433	832 020 005		0.050
Centering tool	A	3	11.0 - 11.5	0.433 - 0.452	832 020 006		0.070
Centering tool	A	4	11.5 - 12.0	0.452 - 0.472	832 020 007		0.070
Centering tool	A	5	12.0 - 12.5	0.472 - 0.492	832 020 008		0.080
Centering tool	A	6	12.5 - 13.0	0.492 - 0.512	832 020 009		0.100
Centering tool	A	7	12.8 - 14.0	0.504 - 0.551	832 020 011		0.110
Retaining arbor for centering tools for group B					832 020 010		0.070
Centering tool	B	8	13.8 - 15.0	0.543 - 0.591	832 020 012		0.120
Centering tool	B	9	14.8 - 16.0	0.583 - 0.630	832 020 013		0.140
Centering tool	B	10	15.8 - 17.0	0.622 - 0.669	832 020 014		0.150
Centering tool	B	11	16.8 - 18.0	0.661 - 0.709	832 020 015		0.180
Centering tool	B	12	17.8 - 19.0	0.701 - 0.748	832 020 016		0.190
Centering tool	B	13	18.8 - 20.5	0.740 - 0.807	832 020 017		0.200
Centering tool	B	14	19.8 - 22.5	0.780 - 0.886	832 020 018		0.250
Retaining arbor for centering tools for group C					832 020 019		0.115
Centering tool	C	15	22.3 - 25.0	0.878 - 0.984	832 020 020		0.340
Centering tool	C	16	24.5 - 27.0	0.965 - 1.063	832 020 021		0.350
Centering tool	C	17	26.5 - 29.0	1.043 - 1.142	832 020 022		0.360
Centering tool	C	18	28.5 - 31.0	1.122 - 1.220	832 020 023		0.400
Centering tool	C	19	30.5 - 33.0	1.201 - 1.299	832 020 024		0.500
Centering tool	C	20	32.5 - 36.0	1.280 - 1.417	832 020 025		0.510
Centering tool	C	21	35.5 - 39.0	1.397 - 1.535	832 020 026		0.530
Centering tool	C	22	38.5 - 42.0	1.516 - 1.654	832 020 027		0.550
Centering tool	C	23	41.5 - 45.0	1.634 - 1.772	832 020 028		0.560
Centering tool	C	24	44.5 - 48.0	1.752 - 1.890	832 020 029		1.000
Centering tool	C	25	47.5 - 51.0	1.870 - 2.008	832 020 030		1.200
Retaining arbor for centering tools for group D					832 020 031		0.215
Centering tool	D	26	50.5 - 54.0	1.988 - 2.126	832 020 032		1.500
Centering tool	D	27	53.5 - 58.0	2.106 - 2.283	832 020 033		1.800
Centering tool	D	28	57.5 - 62.0	2.264 - 2.441	832 020 034		1.900
Centering tool	D	29	61.5 - 66.0	2.421 - 2.598	832 020 035		2.100
Centering tool	D	30	65.5 - 70.0	2.579 - 2.756	832 020 036		2.400
Centering tool	D	31	69.5 - 74.0	2.736 - 2.913	832 020 037		2.600
Centering tool	D	33	77.5 - 82.0	3.051 - 3.228	832 020 039		3.100
Centering tool	D	34	82.0 - 87.0	3.228 - 3.425	832 020 045		3.100
Centering tool	D	36	91.0 - 95.0	3.582 - 3.740	832 020 047		3.300
Centering tool	D	37	95.0 - 99.0	3.740 - 3.897	832 020 048		3.960

* Smaller pipe dimensions on request.

Other accessories for orbital welding

- Earth cable, see page 82
- ESG tungsten grinders, see page 75
- WS2 tungsten electrodes, see page 83
- Torch and cold wire consumables, see page 85