

ARTIFOX

SHELF

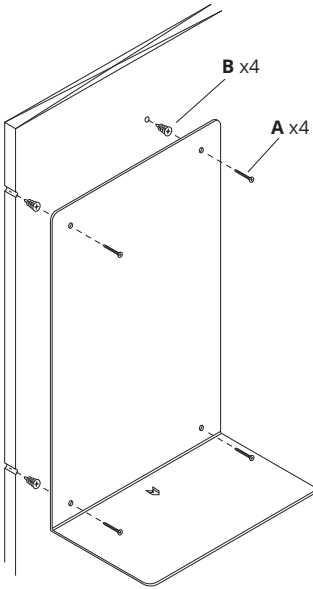

MOUNTING

SHELF can be mounted in either orientation and can hold up to 35lbs. (Dependant on your wall & studs)

DRY-WALL

1. Hold your SHELF in the desired position and mark all 4 holes (Making sure it's level).
2. Drill 1/4in pilot holes through your marks, making sure not to hit electrical, plumbing etc.
3. Using a large phillips-head driver, screw the anchors (B) into holes until flush with wall.
4. Hold SHELF up to holes and screw the provided mounting screws (A).

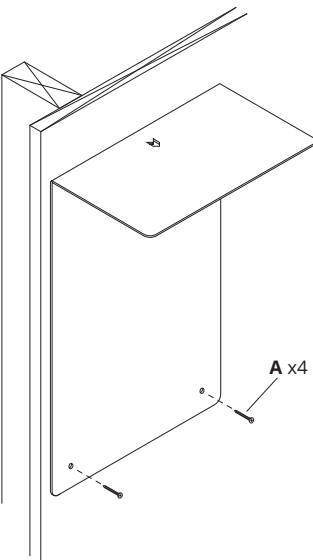

STUDS OR WOOD PANELS

1. Hold SHELF in the preferred mounting position and mark all 4 holes.
2. Drill 1/16in pilot holes through marks, making sure not to hit electrical, plumbing etc.
3. Hold SHELF up to holes and screw the provided mounting screws (A).

NOTES

If necessary you can combine these techniques.

If you're mounting to other surfaces make sure to use anchors that fit #8 screws or if you're using specialty screws be sure they have a similar size and head-shape.