

ARTIFOX

BENCH

COMPONENTS

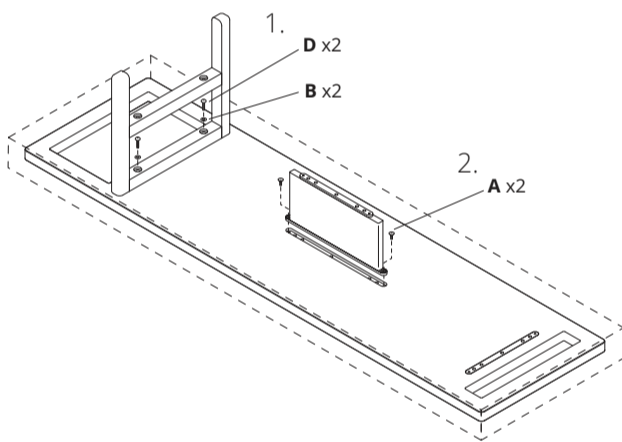
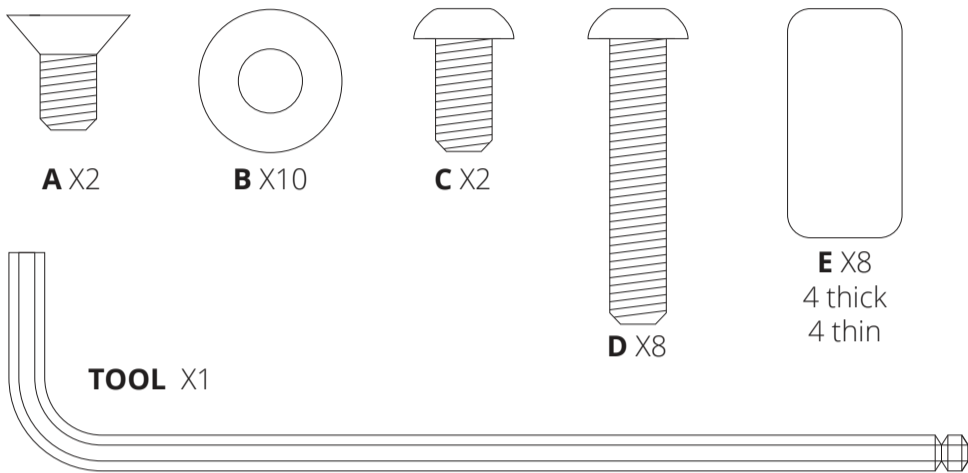

ASSEMBLY

Remove Legs, Support and Components from the box to reveal Top. Flip Top upside down keeping it on the foam in the box or on a soft padded surface.

ATTACH 1st LEG-SET & SUPPORT

1. Use two of the 1/4in bolts (D) and washers (B) to attach one Leg-set to the Top.
2. Use the two 1/2in counter-sunk bolts (A) to attach the Support to the Top.

NOTE: Keep bolts loose enough to adjust while attaching the Shelf.

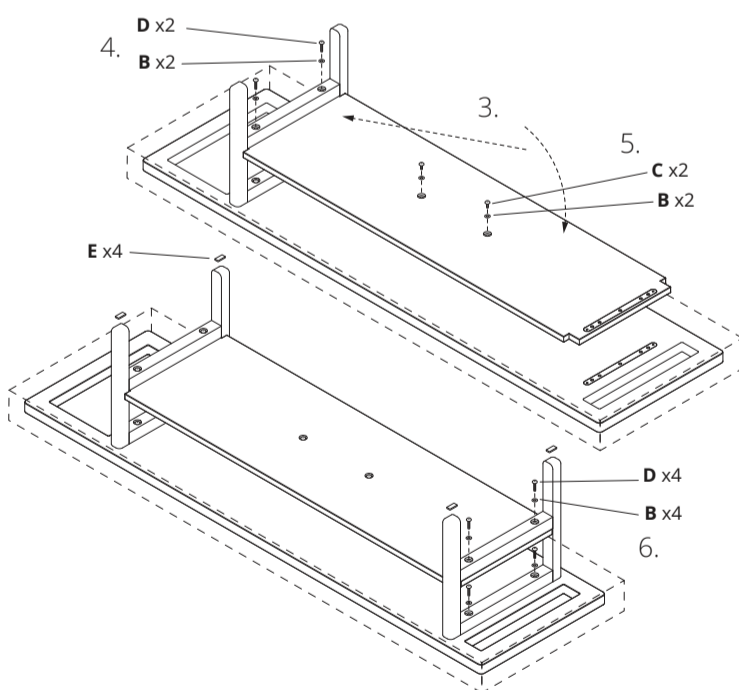

ATTACH SHELF

3. Slot the Shelf into the leg-set and onto the Support so the metal on the Support fits into the opening on the Shelf.

4. Use two of the 1/4in bolts (D) and washers (B) to attach the Leg-set to the Shelf.

5. Use the two 1/2in bolts (C) and washers (B) to attach the Shelf to the Support.

ATTACH 2nd LEG-SET

6. Use four of the 1/4in bolts (D) and washers (B) to attach the Leg-set to the Shelf and Top.

NOTE: Once all bolts are aligned and partially threaded, tighten all bolts (A,C&D).

NOTE: Use the supplied pads (E) to protect sensitive floors. You can also use the two different thicknesses to help level on uneven floors.

FLIP

7. Grab a friend to help you flip the Bench over once completed, but if you're flying solo, make sure to have all bolts tight and flip it slowly.

WARNING: Do not stand or jump on the Bench. Do not sit on, or put pressure on the Scroll or Tray openings.

