

This Drawing and Subject Matter Discussed Herein Are Proprietary Items to Which AI Retains the Exclusive Right of Dissemination, Reproduction, Manufacture, Use and Sale. This Drawing is Submitted in Confidence for Consideration by the Recipient Alone Unless Permission for Further Disclosure is Expressly Granted in Writing by AI.

REVISIONS

ZONE	REV.	DESCRIPTION	DATE	APPROVED
	A	PRODUCTION RELEASE	01/20/2016	
	B	ENCLOSURE UPDATE	2/11/2021	
	C1	ENCLOSURE UPDATED TO ACCOMMODATE VIEWING AREA CENTER	11/7/2021	

NOTES:

- EVIC OVERALL DIMENSIONS, STANDARD AND [METRIC]
- FWD MOUNTING HOLES 4X M4

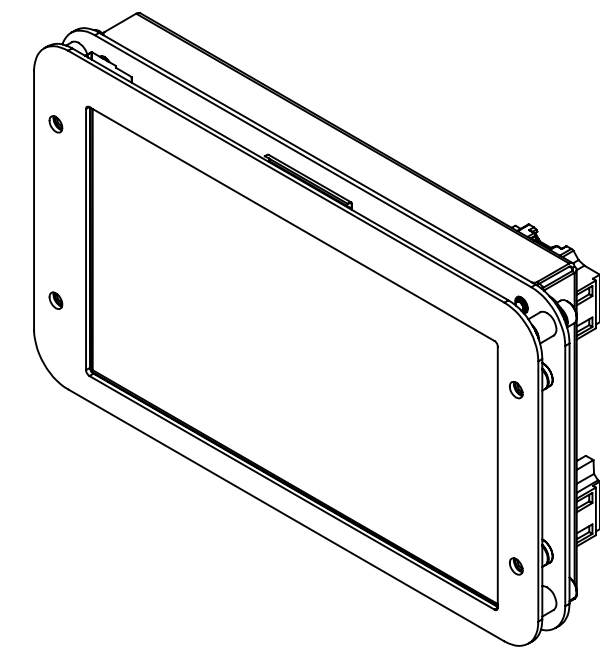
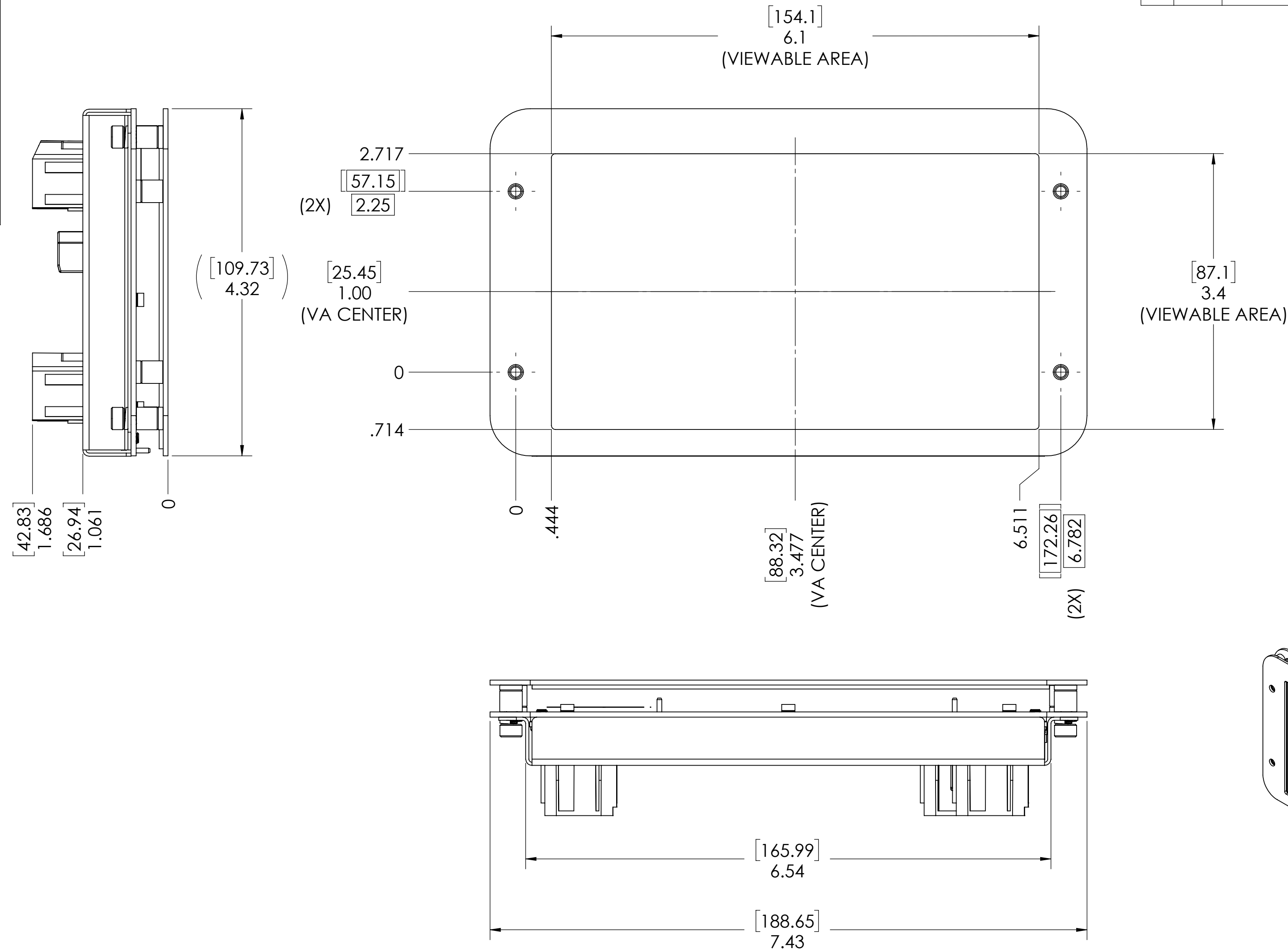

MATERIAL: N/A		 ANDROMEDA INTERFACES 3402 Piazza De Oro Ste 100 Oceanside, CA, 92056 TEL: (877) 332-6055 ai-hmi.com	
FINISH: N/A			
GENERAL INSTRUCTIONS: DIM AND TOL PER ANSI Y-14.5 BREAK AND DEBURR ALL SHARP EDGES DO NOT ANODIZE UNLESS INSTRUCTED TO DO SO CONTACT SOC CONCERNING MISSING DIMENSIONS ALL DIMENSIONS APPLY AFTER PLATING		UNLESS SPECIFIED DIMENSIONS ARE INCHES & MINIMUM TOLERANCES ARE: .X ± 0.1 .XX ± 0.01 .XXX ± 0.005 .XXXX ± 0.0005 FRACTIONS ± 1/64 ANGLES ± 30' SURFACE FINISH 64 --DO NOT SCALE DRAWING--	
		SOLIDWORKS GENERATED DWG ECO MODIFICATIONS MUST BE SIGNED, DATED, & IN PEN APPROVALS: _____ DATE: _____ DRAWN: k.coelho 02/10/21 CHECKED: _____	
		EVIC SIZE: C DWG. NO.: _____ REV.: C1 SCALE: 1:1 FILE: EVIC-REV-C1.STEP SHEET 1 of 1	