

BTU ULTRASONIC HEAT METER INSTALLATION AND USER MANUAL



 **i-meter**[®]
Innovative Metering Solutions

Table of Contents

1. PRODUCT INTRODUCTION	4
1.1. Features	4
1.2 Technical parameters and characteristics	5
1.2.1 Main parameters	5
1.2.2 Technical Parameter.....	5
1.3 Communication Interface Connecting Illustration	7
2. GUIDE FOR TYPICAL INSTALLATION AND MAINTENANCE	9
2.1 For safety reasons, please read the following points carefully	9
2.2 Installation notes	10
2.3 Wiring requirements.....	11
2.4 Several common error installation methods	11
2.5 Temperature sensor installation guide:.....	12
3. DESCRIPTIONS OF THE STATE OF HAZARDOUS SUBSTANCES CONTENT IN PRODUCTS	13
4. WARRANTY COMMITMENT	14
5. LCD	15

WARNING

Field electrical installers must follow proper safety precautions and all local electrical code requirements during electrical installation, meter wiring, and CT installation. During normal operation of this device, hazardous voltages are present which can cause severe injury or death. It is strongly recommended that only qualified, properly trained personnel should perform installation and servicing.

DISCLAIMER

The information presented in this publication has been carefully checked; however, Intellimeter Canada Inc. (ICI) assumes no responsibility for inaccuracies. The information provided in this document is subject to change without notice.

CUSTOMER SUPPORT

To report any issue, please contact ICI at 905.839.9199. Prior to returning any merchandise to ICI, a return material authorization (RMA) number should be obtained from ICI.

STATEMENT OF CALIBRATION

The accuracy and calibration of our instruments are traceable to Measurement Canada, a division of Industry Canada.

CONFIGURATION

The BTU meter is configured by Intellimeter Canada Inc. at ICI's factory according to the customers provided panel schedule.

INSTALLATION CHECKLIST

Make sure you have received the right meter as per your order and packing list.

INSTALLATION DISCLAIMER

INTELLIMETER does not accept any responsibility and will not be liable for any loss or damage or expense of any kind whatsoever and howsoever caused by improper installation of its products, be it indirect, special, incidental or consequential damages (including but not limited to damages for loss of business, loss of profits, interruption or the like). Please refer to Intellimeter's Terms and Conditions of Sale available at <https://intellimeter.ca/pages/terms-of-service-privacy-statement>

ELECTRICAL CODE

Installer is responsible for ensuring that all safety and local electrical codes are followed.

1. Product introduction



1.1. Features

- Internal high capacity 3.6V lithium battery, External optional AC220V or DC24V power supply mode;
- Can be mounted on supply or on return pipeline and can be mounted in either horizontal or vertical direction. The use of ultrasonic technology allows the installation angle-independent.
- DN15-DN25 is installed without the straight pipe;
- Compatible with CJ/T 188、 MODBUS RTU 、 EN13757、 BACnet communication protocol;
- Support optical IrDA, RS485, M-Bus, wM-Bus, pulse input and output, (4 ~ 20) mA Bacnet GPRS Interfaces
- The product conforms to European MID and Chinese CMC certification in line with the European EN1434 and Chinese CJ128-2007 standard. Compatible to the German Heating Association Measurement NOWA protocol.
- The modular design, support thread and flange two connections.

1.2 Technical parameters and characteristics

1.2.1 Main parameters

Accuracy grade	2 grade
Protection level	IP67
Heat consumption calculation	Start from 0.25K
Temperature range	(4~95) °C or (4~130) °C optional
Range of temperature difference	(3~60) K ((2~100) K optional)
Ambient temperature	Class A (5~55) °C or class B (-25~55) °C optional
Power supply	3.6V lithium battery (220 VAC / 7-24 VDC optional)
Battery lifetime	≥10 years
Installation method	Arbitrary angle
Hot (cold) carrier	Water full of measured pipe
Temperature sensor	Pt1000 platinum resistance (Pt500, Pt100 optional)
Maximum working pressure	1.6MPa (2.5MPa optional)
Maximum flow reading (m³)	999999.99
Maximum heat reading (kWh)	99999999
Communication interface	Optical interface, baud rate is 2400bps
	M-Bus module, baud rate is 600 ~ 9600bps;
	RS485 module, baud rate is 600 ~ 9600bps;

1.2.2 Technical Parameter

Nominal flow rate q_p (m³/h)	2.5	2.5	3.5	6	6	10
DN (mm)	20	20	25	25	32	40
L (mm)	130	190	160	260	180	200
L2 (mm)	234	294	280	380	300	328
L1 (mm)	150	150	150	150	150	150
H (mm)	108	108	111	111	114	118
H1 (mm)	60	60	60	60	60	60
B (mm)	105	105	105	105	105	105
Meter screw thread A (inch)	G1B	G1B	G1 ¹ / ₄ B	G1 ¹ / ₄ B	G1 ¹ / ₂ B	G2B

Threaded for union B (inch)	R ^{3/4}	R ^{3/4}	R1	R1	R1 ^{1/4}	R1 ^{1/2}
Pressure loss (kPa/q_p)	17	17	15	20	13	11
Range ratio (q_p : q_i)	250:1 or 100:1 or 50:1 optional					
Pulse output equivalent (kWh)	0.2	0.2	0.25	0.25	0.5	0.5
Pulse output equivalent (L)	1	1	1	1	2	2
Nominal flow rate q_p (m³/h)	0.6	0.6	0.6	1.5	1.5	1.5
DN (mm)	15	20	20	15	20	20
L (mm)	110	130	190	110	130	190
L2 (mm)	204	234	294	204	234	294
L1 (mm)	150	150	150	150	150	150
H (mm)	105	108	108	105	108	108
H1 (mm)	60	60	60	60	60	60
B (mm)	105	105	105	105	105	105
Meter screw thread (inch)	G ^{3/4} B	G1B	G1B	G ^{3/4} B	G1B	G1B
Threaded for union B (inch)	R ^{1/2}	R ^{3/4}	R ^{3/4}	R ^{1/2}	R ^{3/4}	R ^{3/4}
Pressure loss (kPa/q_p)	14	14	14	18	7	7
Pulse output equivalent (kWh)	0.1	0.2	0.2	0.1	0.2	0.2
Pulse output equivalent (L)	1	1	1	1	1	1
Range ratio (q_p : q_i)	100:1 or 50:1 optional			250:1 or 100:1 or 50:1 optional		

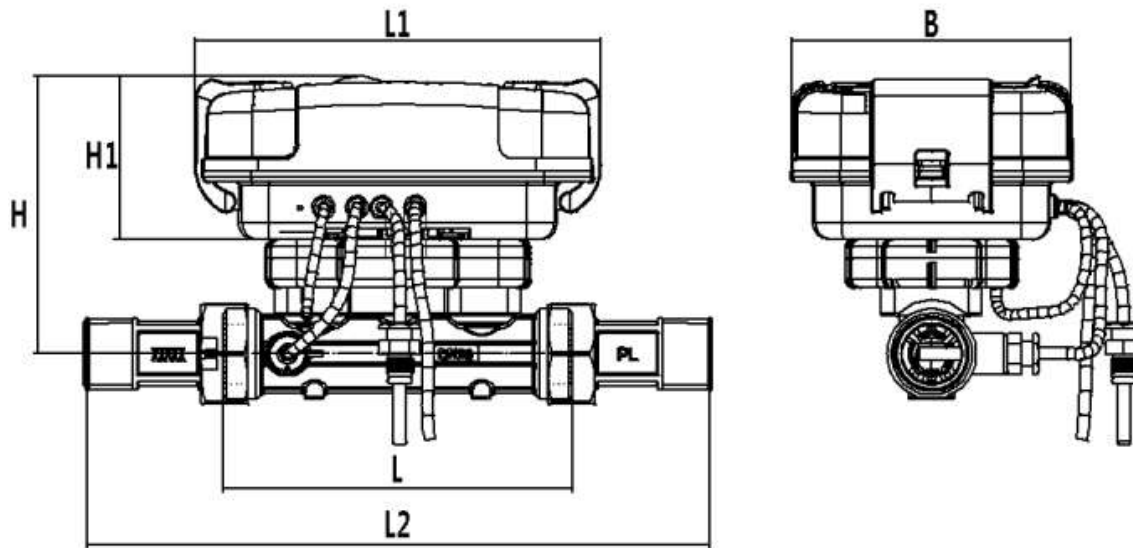

1.3 Communication Interface Connecting Illustration

Terminal diagram (RS485)

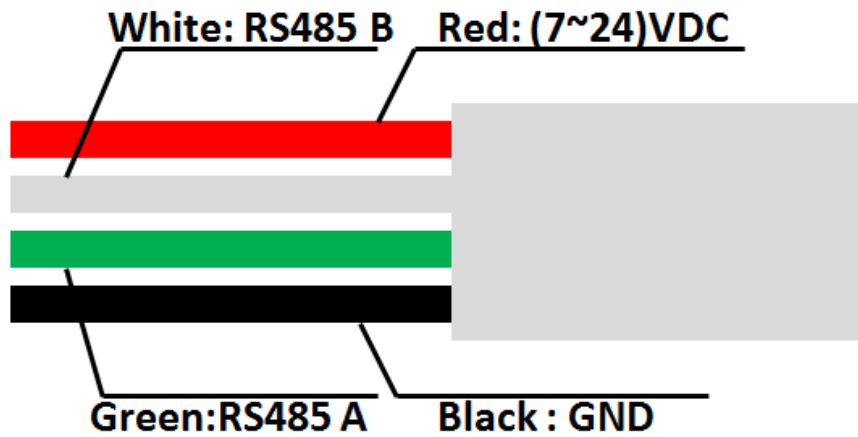

Terminal diagram(Pulse input/output)

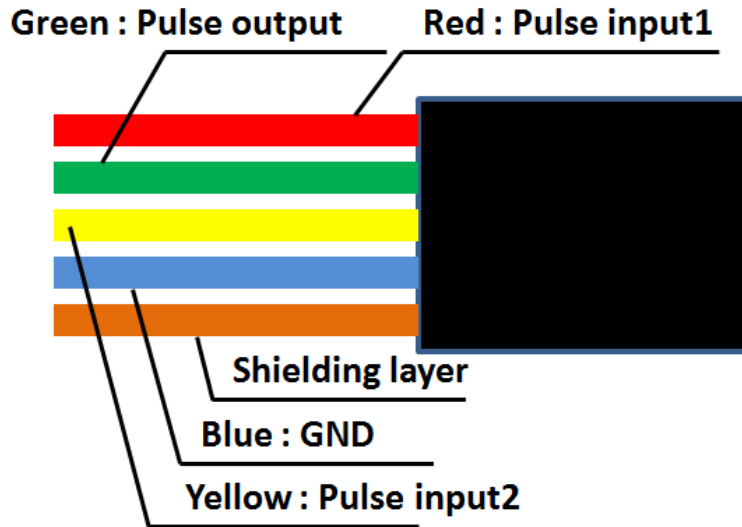

2. Guide for Typical Installation and Maintenance

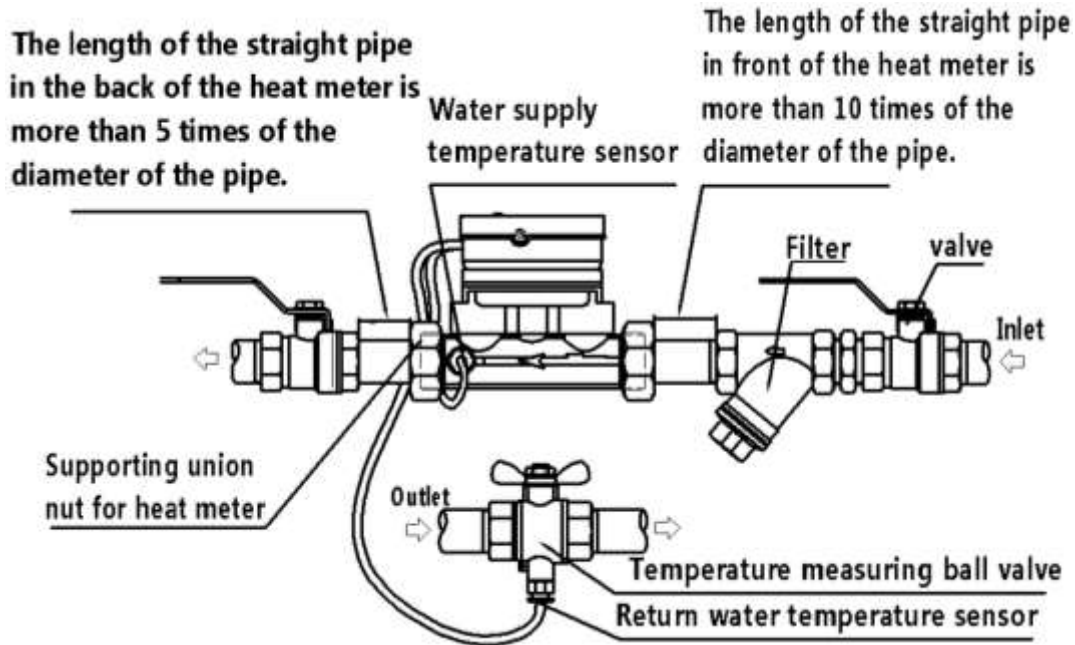

2.1 For safety reasons, please read the following points carefully

- The device is designed for use under the specified specifications. Improper use involves risk and the possibility of damage. Failure to comply with the specified parameters will void the warranty.
- For installations in rooms with flammable and / or explosive substances, the applicable protective measures must be followed.
- Since sharp edges signify a risk of injury, work gloves must be worn.
- Do not install the device in places where it is exposed to toxic, irritating or corrosive gases as well as liquids and dust.
- Make sure that the device is not installed in hazardous locations.
- Installation and removal of the device may be performed only by qualified personnel.
- Installation and removal of the device may only be carried out without pressure
- The required lightning protection measures must be taken into account.

2.2 Installation notes

- For service and maintenance reason we recommend to install a valve ahead and back of the heat meter and filter.
- Please notice valve opening sequence: first, open valve ahead of the heat meter on the inlet side slowly, then open valve back of the heat meter on the outlet side. Finally, open valve on return water pipe, to protect heat meter from the impurity flowing back to meter body, like sand and stone, which at the bottom of the pipe.
- Notice: opening valve action should be slow, to prevent water hammer effect. If opening valve quickly, it may damage heat meter and components.
- During heat meter running, try to avoid closing the valve on pipeline completely, to prevent heat meter freezing without heat water flowing in pipeline for a long time.
- If heat meter is installed outdoor, there should be protective measures, to prevent accident damage and sabotage.
- The pipes must be cleaned before installing the heat meter and keep enough straight pipes in inlet and outlet. The length of the inlet pipe in front of the heat meter should not be ten times less than that of the pipe diameter. The length of the outlet pipe of the heat meter should not be 5 times less than that of the pipe diameter. If the device is mounted on a confluence of two return pipes, the pipe should be 10 times as long as the pipe diameter between the heat meter and the joint (such as the T-joint) to ensure uniform pipe mixing.
- Water in heat exchange system should generally be clean, dematerialized and purely to ensure the heat meter running smoothly to overcome damaging. If the flow rate decreases significantly, this indicates a contamination of the filter. In this case, the filter should be cleaned or replaced.
- Heat meter belongs to measuring instrument, and must be calibrated regularly according to the national standards and the battery needs to be changed when necessary.
- Heat meter belongs to valuable precision instrument, so handling them with care. A manipulation of the core components such as, calculator, temperature sensor etc. is prohibited. Please take care that the cable connections are not damaged during installation.
- Take appropriate measures to protect the unit from possible sources of heat.
- In order to ensure the correct operation, please pay attention to the directional arrows on the components.

2.3 Wiring requirements

- The connecting cables between the components must not be changed.
- The bus must adopt multi strand shielded twisted pair wire, diameter is not less than 0.75 mm².
- It is prohibited to install signal lines and power lines in the same slot, in order to avoid signal interference.
- The RS485 bus must be reliable grounded.
- The RS485 network generally adopts the hand structure wiring, avoid star connection and irregular branch connection. The star structure will produce a reflection signal, which will affect the RS485 communication

2.4 Several common error installation methods

- When installation, please screw the pipe nut with a wrench. Do not use hand holding the plastic box body of calculator and then use the wrench to tighten the nut, because it may cause damage.

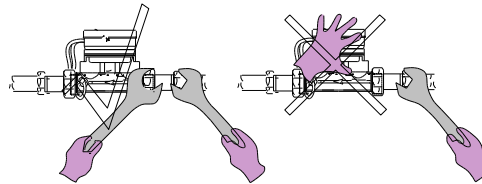

- At a vertical installation scenario, the heat meter needs to be installed on the flow upward straight pipe. It will affect the measurement accuracy, even lead to immeasurability, if installed on the flow downward pipeline. Because the water cannot fill the pipe completely.

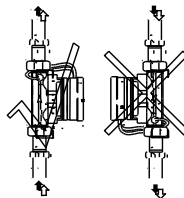

- Please install the flow meter in the lowest position while installed in the "U" type. Because it is likely to gather the air in the pipe at the highest point, causing immeasurability or inaccurate measurement.

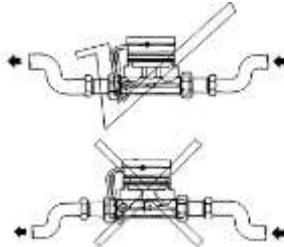

2.5 Temperature sensor installation guide:

Each meter has two temperature sensors, water supply temperature sensor with a red label, and the return water temperature sensor with a blue label. The water supply temperature sensor or the water return temperature sensor is fixed on the flow sensor according to the requirement (forward or return). Only the other temperature sensor needs to be installed as the following steps:



1. Remove the plug from the ball valve screw hole



2. Remove O type ring from temperature sensor probe, and mount it to the ball valve screw hole.



3. Insert the temperature sensor probe into the temperature measuring ball valve screw. Tighten it properly with a wrench.



4. The seal clamp passes through the temperature sensor and ball valve seal hole, and seals should be locked.

3. Descriptions of the State of Hazardous Substances

Component Name	Toxic and Hazardous Substances or Elements					
	Lead (Pb)	Mercury (Hg)	Cadmium (Cd)	Chromium 2+ Cr ²⁺	Multi-bromine PBB	Two phenyl-ether PBDE
Complete Machine	○	○	○	○	○	○

- : It indicates that the content of the toxic and hazardous substances in all homogeneous materials of this part doesn't exceed the limits set by the SJ/T11363-2006 standard.
- × : It indicates that the content of the toxic and hazardous substances in one certain homogeneous material of this component exceeds the requirements specified in the SJ/T11363-2006 standard.

Note :

- 1 . This table shows that our products may contain these substances, but the information may be updated with the technology development.
2. The right to interpret the component definition in this table belongs to our company.
3. According to the EU waste electrical and electronic recycling directive 2002/96/EC (WEEE), if you need to scrap the product, you can return it to our company. Ploumeter can dispose of the discarded product. You can also hand it over to the recycling company. Not allowed to be discarded with other living garbage



4. Warranty commitment

1. **Free Warranty:** If the product broke down or didn't work normally, Ploumeter is in charge of the gratis repair or replacement in the premise of intact seal, from the date of your purchase (the formal purchase invoice date). But we won't undertake related charges of the door to door service.
2. **Exempt from Warranty Obligations:** In order to protect your legitimate rights and interests, and avoid unnecessary losses, please notice that our company does not assume warranty obligations to the failure, abnormal operation or damage caused by the following conditions. It needs to pay maintenance cost.
 - a. When the product is beyond the warranty period ;
 - b. Product damage due to the error use, self dismounting, improper maintenance and other reasons ;
 - c. Open the product seal privately ;
 - d. Accident factors (transport, collision, etc.) or man-made damage ;
 - e. Other damage caused by force majeure such as natural disasters (earthquake, fire etc.) and so on.
3. **After Sales Service:** if the product goes wrong when normal use , please contact the supplier or the Ploumeter sales department, in order to provide you with immediate services.
4. **About Battery:** the normal depletion cycle of the battery is 10 years, it is recommended to purchase and replace it before the expiration, in order to avoid inaccurate measurement due to battery under voltage.
Important Statement: We have tried our best to guarantee the product data reliability in design, but we can't guarantee that there is no problem in all products.

Ploumeter will try to recover the loss data for the customers, which caused by the product breakdown and other reasons. But we won't undertake the losses caused by the measurement data loss. Please read and save measurement data regularly.

5. LCD

The LCD display can be operated with the bottom under the display.

Menu Overview:

- The A1 menu displays the basic data.
- Menu A2 displays the reference data. These are for example: date, manufacturing number, first level address, etc.
- The monthly cumulative heat and flow value of the first 24 months is displayed in menu A3.
- The statistical data are displayed in the A5 menu.

Note: Only the cool-heat meter (for heating, cooling) display "the accumulative amount of cold"

Error Codes	Fault information	Prompt service
err0___	Incorrect meter direction or wrong installation	Checking the flow or mounting direction; correction if necessary
err_1___	negative temperature difference	Check the installation position of the sensor; replace it if necessary
err__2__	Open circuit of water supply temperature sensor	Repair or replacement by professionals
err__3__	Short circuit of water supply temperature sensor	Repair or replacement by professionals
err__4_	Open circuit of return water temperature sensor	Repair or replacement by professionals
err__5_	Short circuit of return water temperature sensor	Repair or replacement by professionals
err___6	Air tube	Pipes do not have water or water not full of the pipe
	Low battery	Need to replace the battery by professional personnel

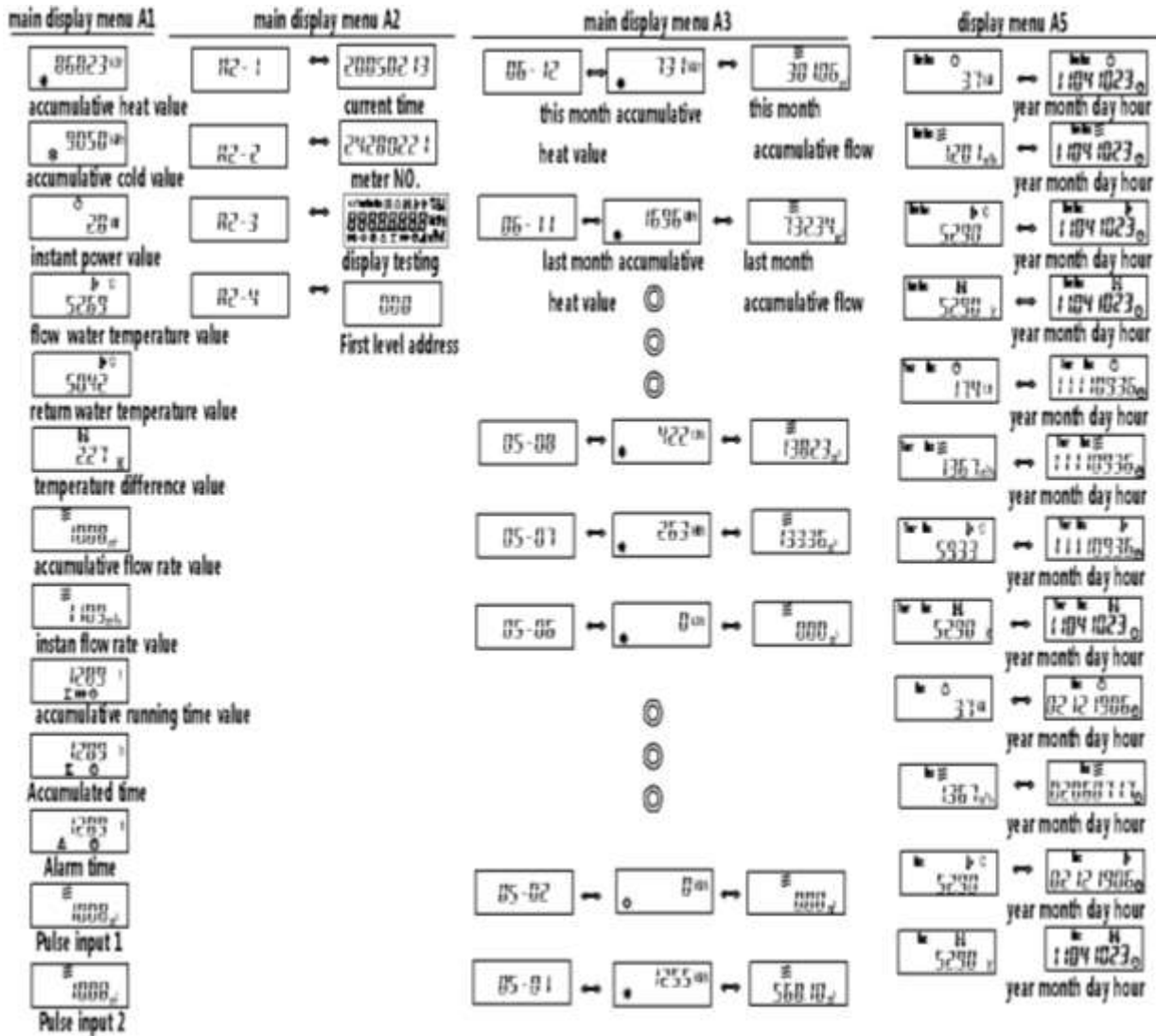

Packing List

Name	Model	Number	Remarks
Ultrasonic heat meter	RC82	1	*Expressed as the main component
Instructions		1	
Declaration of conformity		1	

Thank you for giving us the opportunity to serve you. We appreciate your business and the confidence you have placed in us.

Please visit us @ <https://intellimeter.ca>
or call us @ 905-839-9199 if you need any further assistance.