

ROMAN AND WILLIAMS

GUILD

NEW YORK

STEPHEN ALESCH AND ROBIN STANDEFER PRESENT

ROM OVO COLLECTION



ABOVE
OLD GROWTH WHITE
OAK SOAPED

CHAIR DIMENSIONS
18 ½" W × 18 ½" L × 31 ½" H
SEAT HEIGHT 17"

TABLE DIMENSIONS
36" W × 109" L × 29" H

PRICE
CHAIR FROM \$4,935
TABLE FROM \$17,750

The *OVO* collection, created by *Stephen Alesch* and *Robin Standefer* for *RW Guild*, features handcrafted sculptural furniture that embraces a geometry of contours and curves. *OVO* represents an evolution in *Alesch* and *Standefer's* furniture designs, and their practice, which marks twenty years this fall. Expanding upon a vocabulary established in one branch of their founding collection, *OVO* embraces curving, organic shapes and softer profiles that draw from the beauty and complexity found in nature—specifically the ovate-shape leaves that inspired the collection's name.

Found on the elms and beeches that dot the designers' property in Montauk, ovate leaves have a narrow top and an elliptical base that is echoed in the contours of the table and in the chair's gently sloping, rounded back. The chair also features a distinctive slender void along its central spine, abstractly evoking the sturdy midrib of the ovate leaf.

FIFTY-THREE HOWARD STREET
NEW YORK, NY 10013



RWGUILD.COM | @RWGUILD
212-852-9099



PROTOTYPE OF THE OVO CHAIR WITH DESIGN AND CONSTRUCTION NOTES.

As with all of *Alesch and Standefer's* designs for *RW Guild*, the *OVO* table and chair underwent a rigorous two-and-a-half-year process of ideation, sketching, prototyping, and refinement before the final designs were realized. Each finished piece is crafted to order using sustainably sourced materials in workshops using time-honored techniques. The collection launches together with the introduction of oxidized oak at *Roman and Williams Guild*—a naturally-occurring chemical process that changes the inherent pigmentation of the wood. As with all of the woods and finishes, the materials are chosen for their sturdiness and longevity, conceived as modern heirlooms, made to last for generations.



OVO TABLE AND CHAIRS IN OLD GROWTH WHITE OAK SOAPED.



OVO CHAIR IN OLD GROWTH WHITE OAK SOAPED WITH BURNISHED BRASS HARDWARE.





DESIGN STATEMENT

The *OVO* chair and table continue a narrative we set out to explore in our founding collection for *RW Guild*: to continue to develop and build a family of furniture with a variety of shapes that can live together. These new pieces represent a design language that expands on the curvaceous branch of the family, a branch that may feel geometrically and architecturally apart from the rest, but spiritually shares the same DNA, and harmonizes with the broader collection. This idea—that of unity in variety—has been central to *Roman and Williams* since its inception and is integral to everything we make. It is an essential principle in the natural world—which is also of great importance to us—long recognized by botanists as referring to patterns of harmony achieved through the combination of disparate elements.

In many ways, it is fitting that it is also the title of an 1850s book by Christopher Dresser, the British father of design, who studied botany and applied these ideas in his practice, as the botanical is at the very heart of the collection. At its essence, *OVO* was about interpreting the sacred geometries of nature—the astounding complexity and purity of which we are continually humbled by, and surrounded by in our laboratory of a home in the wilds of Montauk. It was here that we were inspired by the perfection and symmetries found in the ovate leaves of the area—both by its spines, and by the shape of the leaf itself, which is wider at the base than at the midpoint and tapers toward the apex.

OVO began over two years ago with loose concepts and sketches that both of us worked on for months. Miniature models came next, followed by full-scale prototypes in cedar, a soft, pliable wood that *Stephen* could sculpt into precise curves he realized in his woodshop. We created a half dozen prototypes of both on our journey of creating the *OVO* chair and table, both of which went through numerous iterations. The chair's back was initially crafted by combining 16 vertical slices of wood—calling to mind the ribs and veins in the leaves—each one cut and shaped by hand to achieve the ideal curvature for hugging the human form. In the final production design, we translated the sculpted back into a composition of six pieces of wood, thanks to precise CNC milling, which, we are proud to say, results in an incredibly comfortable chair.

A similarly meticulous approach was taken with the *OVO* table, which *Stephen* hand-worked to create the subtle convex edge profile and curvature of the top, as well as the gentle taper of the robust, precisely angled legs. As with the chair, we took inspiration from the way that wind, water, and air wear away at leaves over time, hewing away at the edges. Ultimately, both the table and the chair achieve an exquisite sense of balance and finesse that belies the considerable weight of their solid-wood construction. Totally at rest together, these pieces also play well with the other *Roman and Williams* furnishings for *RW Guild*.

— *STEPHEN ALESCH and ROBIN STANDEFER*





OXIDIZED OAK

OXIDIZED OAK



OXIDIZED OAK

FIFTY-THREE HOWARD STREET
NEW YORK, NY 10013



RWGUILD.COM | @RWGUILD
212-852-9099



OLD GROWTH WHITE OAK SOAPED



OLD GROWTH WHITE OAK SOAPED



OLD GROWTH WHITE OAK SOAPED

FIFTY-THREE HOWARD STREET
NEW YORK, NY 10013



RWGUILD.COM | @RWGUILD
212-852-9099

OVO CHAIR

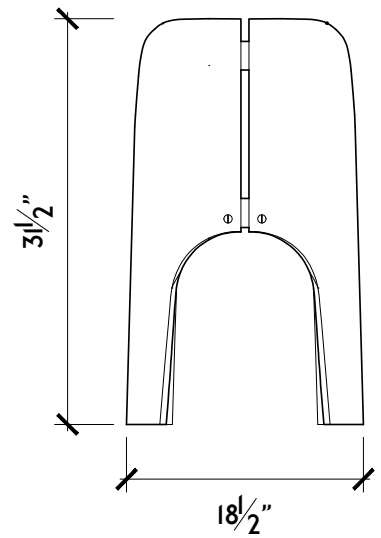
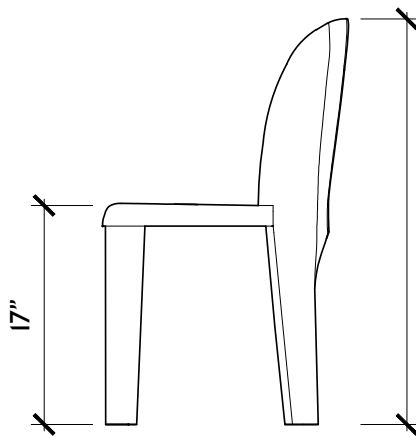
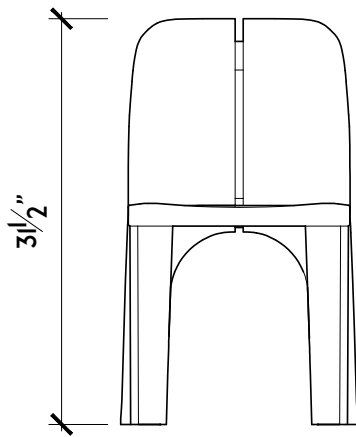
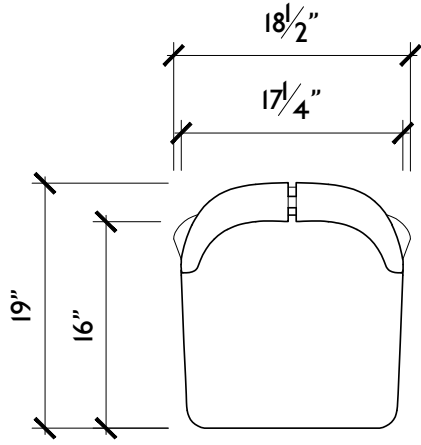

WOOD FINISHES

SIGNATURE

BLACK INKED OAK
OXIDIZED OAK
OYSTER WAXED OAK

RARE

CLARO WALNUT
BRILLIANT POLISH
CLARO WALNUT
DANISH OIL

DISTINCTIVE

FIGURED
BLACK WALNUT
BRILLIANT POLISH
FIGURED
BLACK WALNUT
DANISH OIL
OLD GROWTH
WHITE OAK
SOAP

METAL FINISHES

SIGNATURE

BURNISHED BRASS
DARK BRASS
BLACKENED BRASS

DISTINCTIVE

BURNISHED NICKEL
FRENCH SILVER
ROSE GOLD
PEWTER

DIMENSIONS

18 1/2"W x 18 1/2"L x 31 1/2"H
SEAT HEIGHT 17"



OVO TABLE

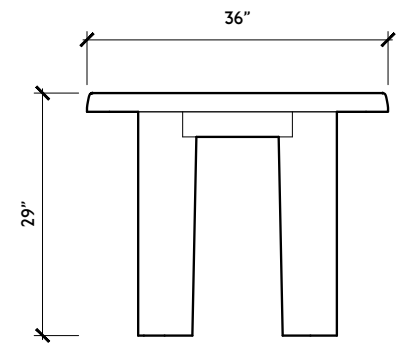
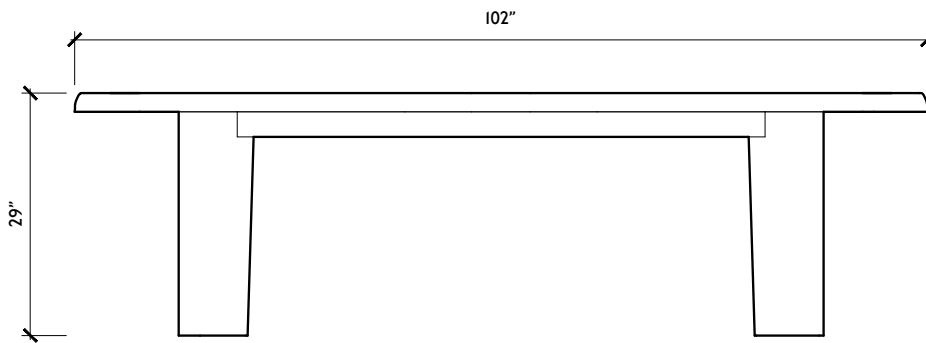
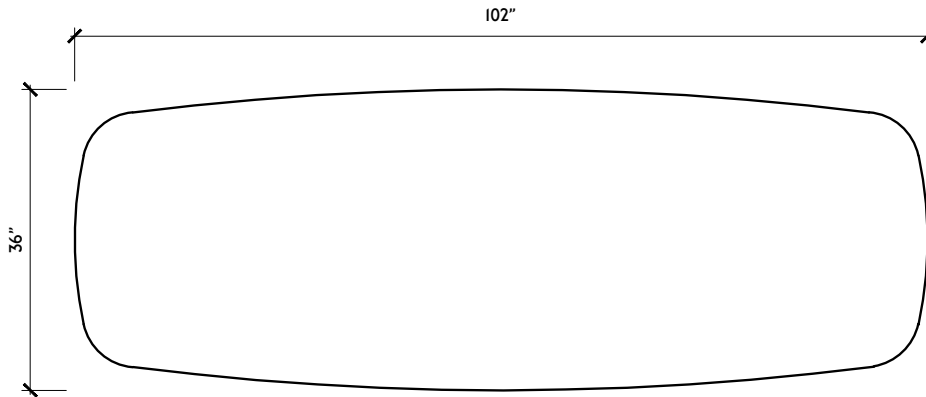

WOOD FINISHES

SIGNATURE

BLACK INKED OAK
OXIDIZED OAK
OYSTER WAXED
OAK

RARE

CLARO WALNUT
BRILLIANT POLISH
CLARO WALNUT
DANISH OIL

DISTINCTIVE

FIGURED
BLACK WALNUT
BRILLIANT POLISH
FIGURED
BLACK WALNUT
DANISH OIL
OLD GROWTH
WHITE OAK
SOAP

METAL FINISHES

SIGNATURE

BURNISHED BRASS
DARK BRASS
BLACKENED BRASS

DISTINCTIVE

BURNISHED NICKEL
FRENCH SILVER
ROSE GOLD
PEWTER

DIMENSIONS

OVO TABLE 102"
36"W × 102"L × 29"H

OVO TABLE 109"
36"W × 109"L × 29"H



ROMAN AND WILLIAMS

GUILD

NEW YORK

ABOUT THE CREATORS

STEPHEN ALESCH & ROBIN STANDEFER



Robin Standefer and Stephen Alesch are the founders and principals of Roman and Williams and RW Guild. They present a radical vision for the home and a way of living that is not just beautiful and luxurious; it is deeply connected to nature, culture, and community. Following in a tradition of makers who create forms, shapes, and ideas, every piece has a story informed by their years of work and study in the fields of architecture, film, fine art, and interior design. Each of Robin and Stephen's Original Designs is the product of deep research, exhaustive sourcing, and many stages of hand-drafting, constructing, and prototyping—quality is stubbornly uncompromising. Throughout all stages of production, each piece champions natural materials, and the master craftsmen and artisans who have dedicated their lives to proven, ancient techniques and methods. RW Guild Original Designs are about endurance and can be maintained and repaired, every piece a modern heirloom made to last for generations

FIFTY-THREE HOWARD STREET
NEW YORK, NY 10013



RWGUILD.COM | @RWGUILD
212-852-9099