

ROMAN AND WILLIAMS  
**GUILD**  
 NEW YORK  
 ORIGINAL DESIGNS

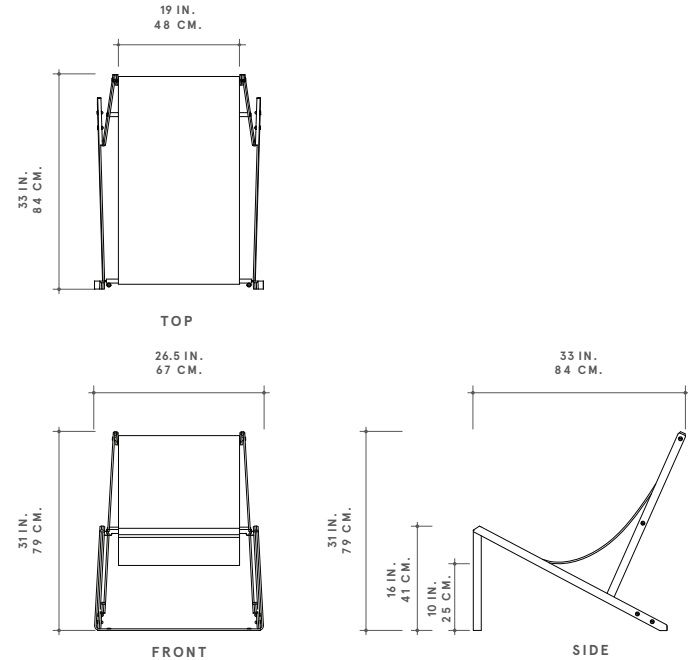

ROMAN AND WILLIAMS GUILD ORIGINAL DESIGNS  
**SLING CHAIR**

SLING EXPRESSES THE RELATIONSHIP BETWEEN STRENGTH, LIGHTNESS, AND PRECISION. THE CONTINUITY OF THE BENT AND FOLDED FRAME IS PUNCTUATED BY EXPOSED HARDWARE. LEGS ARE SLIGHTLY SPLAYED FOR ADDITIONAL STABILITY. OUR CUSTOM GUILD LEATHER WRAPS AROUND THE FRAME AND AN UPHOLSTERED CUSHION PROVIDES A HEADREST. THE UNIQUE TWISTED JOINTS ELIMINATE THE NEED FOR WELDING.

**DIMENSIONS**  
 26.5"W x 33"L x 31"H

**PICTURED**  
 BLACKENED STEEL FRAME, BURNISHED BRASS HARDWARE,  
 BROWN SUEDE

FIFTY-THREE HOWARD STREET, NEW YORK, NY 10013

**METAL FINISHES**

**SIGNATURE**  
 BURNISHED BRASS  
 DARK BRASS  
 RAW STEEL  
 BLACKENED STEEL  
 POLISHED STEEL

**GUILD LEATHERS**

AVAILABLE IN A VARIETY  
 OF GUILD LEATHERS

**DIMENSIONS**

26.5"W x 33"L x 31"H



RWGUILD.COM | @RWGUILD | 212-852-9099