

ROMAN AND WILLIAMS
GUILD
 NEW YORK
 ORIGINAL DESIGNS

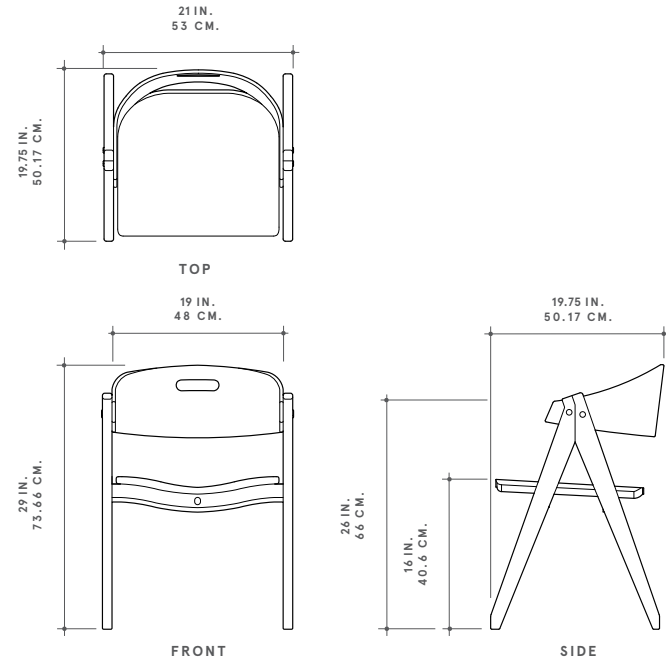

ROMAN AND WILLIAMS GUILD ORIGINAL DESIGNS
JACQUE WOOD

JACQUE'S STURDY CUP UNDERCARRIAGE IS SUPPORTED BY PENCIL-TAPERED LEGS THAT MEET LIKE A PRECISION COMPASS IN AN ACUTE, INCISIVE "V" FROM OUR ARCHITECTURAL LANGUAGE OF FORMS. BENT PLY CURVE MEETS THE FORWARD CANTED LEG JOINT. A SEAMLESS INTERIOR BACK FLOATS SUSPENDED OVER THE SEAT, WITH A CHARACTERISTIC CUTOUT HANDLE. A COMPLETE REIMAGINING OF A 1930'S FRENCH ART DECO METAL CHAIR BY JACQUES ADNET AND A TRIBUTE TO HIM.

DIMENSIONS
 21"W x 19.75"L x 29"H
 16" SEAT HEIGHT

PICTURED
 FIGURED BLACK WALNUT WITH BRILLIANT POLISH, BURNISHED BRASS HARDWARE

FIFTY-THREE HOWARD STREET, NEW YORK, NY 10013



WOOD FINISHES

SIGNATURE

OAK
 BLACK INKED
 OXIDIZED
 OYSTER WAXED

DISTINCTIVE

FIGURED BLACK WALNUT
 BRILLIANT POLISH
 DANISH OIL
 OLD GROWTH
 WHITE OAK
 SOAP

METAL FINISHES

SIGNATURE

BURNISHED BRASS
 DARK BRASS
 BLACKENED BRASS
 BURNISHED NICKEL
 FRENCH SILVER

DISTINCTIVE

ROSE GOLD
 PEWTER

DIMENSIONS

21"W x 19.75"L x 29"H
 16" SEAT HEIGHT