

ROMAN AND WILLIAMS
GUILD
 NEW YORK
 ORIGINAL DESIGNS

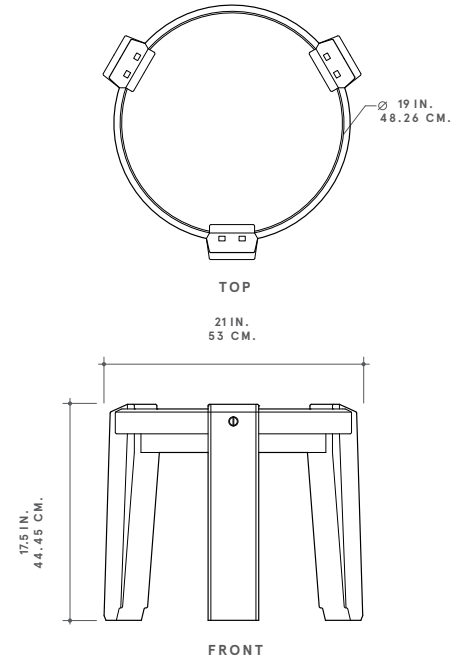

ROMAN AND WILLIAMS GUILD ORIGINAL DESIGNS
HUB SIDE

OUR HUB SIDE TABLE IS INTRICATELY ASSEMBLED IN BUTCHER-BLOCK STYLE; MADE UP OF INDIVIDUALLY CUT PIECES ARRANGED BY HAND AND THEN THE ENTIRE SURFACE IS CARVED INTO A DEBIT. HOOVED LEGS CONSIST OF THREE PIECES OF WOOD LAMINATED TOGETHER AND SPLINED WITH EXPOSED EDGES EASED. NOTCHED INTO PLACE USING MASTERFUL WOODWORKING THEY GRAB ONTO THE TOPS LIPPED AND BEVELED EDGE. MADE WITH A CHOICE OF SIDE OR END GRAIN WOOD, WHICH HAS FOR CENTURIES BEEN A TECHNIQUE OF ENDURING STRENGTH EXPOSING THE NATURAL CHARACTER OF THE WOOD. EXPOSED ATTACHMENTS FEATURE CUSTOM ROMAN AND WILLIAMS GUILD METAL HARDWARE.

DIMENSIONS
 21"OAW × 17.5"H
 19"DIA TABLETOP

PICTURED
 FIGURED BLACK WALNUT WITH DANISH OIL,
 BURNISHED BRASS HARDWARE

FIFTY-THREE HOWARD STREET, NEW YORK, NY 10013

WOOD FINISHES

SIGNATURE

OAK
 BLACK INKED
 OXIDIZED
 OYSTER WAXED

DISTINCTIVE

FIGURED BLACK WALNUT
 BRILLIANT POLISH
 DANISH OIL

OLD GROWTH
 WHITE OAK
 SOAP

MAPLE
 OXIDIZED

METAL FINISHES

SIGNATURE

BURNISHED BRASS
 DARK BRASS
 BLACKENED BRASS
 BURNISHED NICKEL
 FRENCH SILVER

DISTINCTIVE

ROSE GOLD
 PEWTER

STONE TOP OPTIONS

HONED BLACK
 ST. LAURENT MARBLE
 HONED WHITE
 MACAUBAS QUARTZITE
 HONED ARABESCATO
 CORCHIA MARBLE
 HONED FANTASY
 QUARTZITE

DIMENSIONS

21"OAW × 17.5"H
 19"DIA TABLETOP



RWGUILD.COM | @RWGUILD | 212-852-9099