

ROMAN AND WILLIAMS
GUILD
 NEW YORK
 ORIGINAL DESIGNS

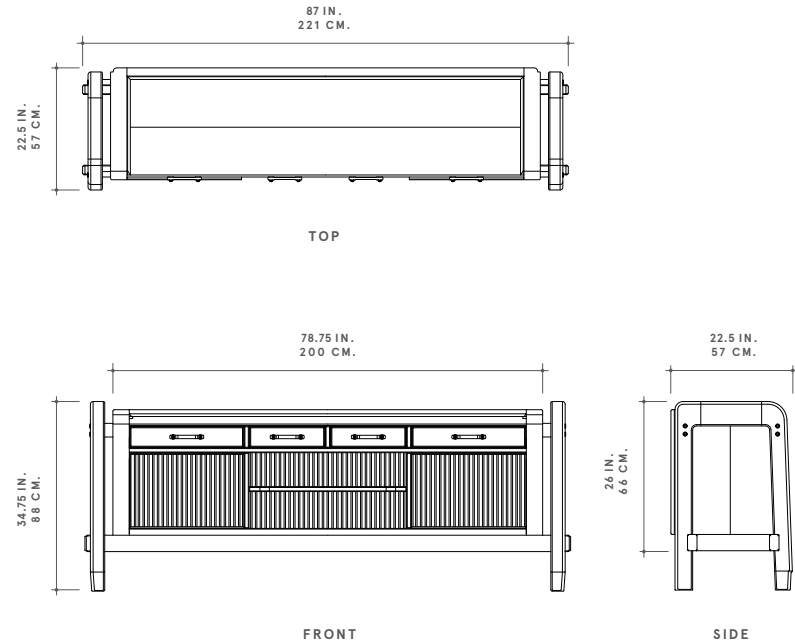

ROMAN AND WILLIAMS GUILD ORIGINAL DESIGNS
EATER

OUR AWARD-WINNING EATER DEBUTED IN MILAN, ITALY DURING SALONE DEL MOBILE. METICULOUSLY HAND-CRAFTED, HIGHLY DETAILED, AN ALCHEMY OF LEATHER, WOOD, AND METAL IT DISPLAYS OLD WORLD, TRUSTED TECHNOLOGY. SUSPENDED ON A FRAME BETWEEN TWO LEGS, WITH FINE DETAILING INCLUDING CHAMFERS AND CUTOUTS. TWO TAMBOUR CABINETS FOLD DOWN AND EXHIBIT THE QUALITY OF THE TIMBER, FURTHER HIGHLIGHTED BY FOUR DRAWERS, AND TWO SHELVES. CHARACTERISTIC HOOVED FEET POINT INWARD. CUSTOM HARDWARE WITH EXQUISITE MACHINING AND JOINERY TIES IT ALL TOGETHER.

DIMENSIONS
 87"W x 22.5"L x 34.75"H

PICTURED
 FIGURED BLACK WALNUT WITH DANISH OIL,
 BURNISHED BRASS HARDWARE

WOOD FINISHES

SIGNATURE

OAK
 BLACK INKED
 OXIDIZED
 OYSTER WAXED

DISTINCTIVE

FIGURED BLACK WALNUT
 BRILLIANT POLISH
 DANISH OIL
 OLD GROWTH WHITE OAK
 SOAP

METAL FINISHES

SIGNATURE

BURNISHED BRASS
 DARK BRASS
 BLACKENED BRASS

DIMENSIONS

87"W x 22.5"L x 34.75"H

**INTERIOR DRAWERS
 DIMENSIONS**

DRAWER
 19.75"W x 12.5"L x 3"H
 12.7"W x 12.5"L x 3"H

DOORS
 21"W x 18"L x 13.9"H
 28.9"W x 17.6"L x 13.9"H

