

ROMAN AND WILLIAMS
GUILD
 NEW YORK
 ORIGINAL DESIGNS

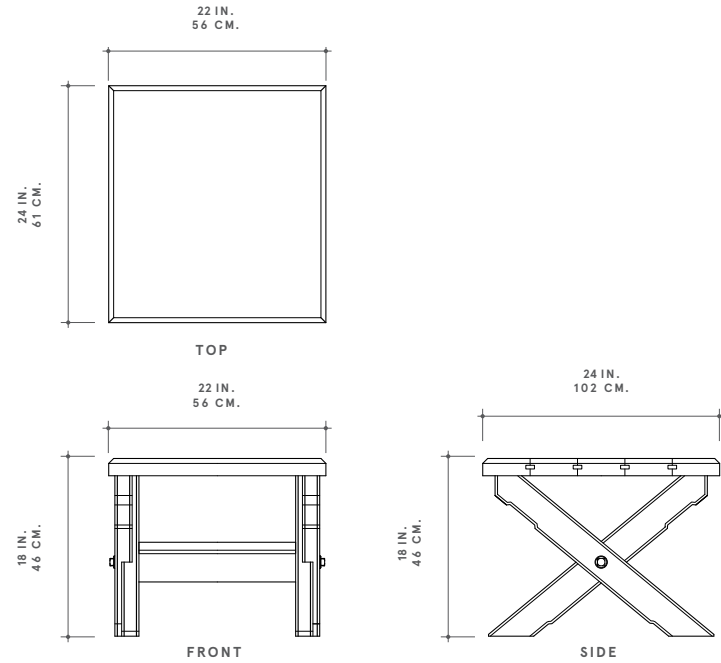

ROMAN AND WILLIAMS GUILD ORIGINAL DESIGNS
AXIS SIDE

A MEDITATION ON “X” A FORM INHERENT IN STRUCTURAL CONSTRUCTION, OUR AXIS SERIES PROVES TO BE AS STYLISH AS IT IS MUSCULAR. THE FLUSH SEAMS OF THE WOOD PLANK TOP FEATURE EXPOSED SPLINES THAT ENSURE LEVELNESS, STABILITY, AND LONGEVITY. BEVELED EDGES OF OUR AXIS LEGS INVITE AND ECHO OUR CHARACTERISTIC SUBTRACTIVE NOTCHES AND HOOVED FEET. EXPOSED CUSTOM DESIGNED ROMAN AND WILLIAMS GUILD HARDWARE TAKES THE FORM OF A MACHINED SQUARE NUT WITH QUILTED EDGES AND BUILT-IN WASHER. A HORIZONTAL, ANGLED WOOD MEDIAL STRETCHER TIES THE VERTICAL ELEMENTS TOGETHER.

DIMENSIONS
 24”W x 22”L x 18”H

PICTURED
 BLACK INKED OAK,
 BURNISHED BRASS HARDWARE

WOOD FINISHES

SIGNATURE

OAK
 BLACK INKED
 OXIDIZED
 OYSTER WAXED

DISTINCTIVE

FIGURED BLACK WALNUT
 BRILLIANT POLISH
 DANISH OIL

OLD GROWTH WHITE OAK
 SOAP

MAPLE
 OXIDIZED

METAL FINISHES

SIGNATURE

BURNISHED BRASS
 DARK BRASS
 BLACKENED BRASS
 BURNISHED NICKEL
 FRENCH SILVER

DISTINCTIVE

ROSE GOLD
 PEWTER

DIMENSIONS

24”W x 22”L x 18”H

