

ROMAN AND WILLIAMS  
**GUILD**  
NEW YORK  
ORIGINAL DESIGNS

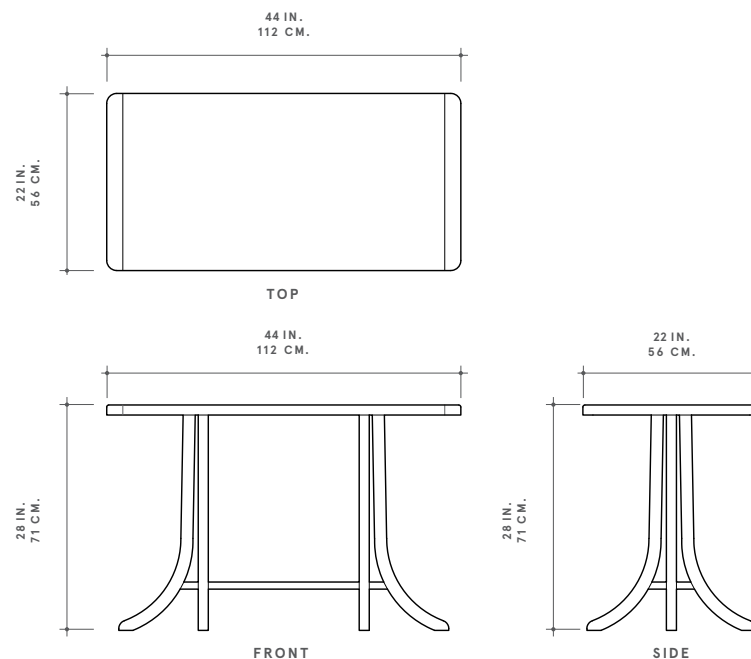

ROMAN AND WILLIAMS GUILD ORIGINAL DESIGNS  
**ANGELICA FOR FOUR**

ANGELICA IS WHERE FLUIDITY MEETS MASTER WOODWORKING. REFINED AND WELL-EDITED FEATURING A SUBSTANTIAL, THICK TOP WITH BREADBOARD ENDS THAT HOLD THREE FINE PIECES OF WOOD WITH FLUSH SEAMS. MORTISED, SOLID WOOD, CURVED LEGS UNITE WITH A WOOD BRACKET AND JOIN A WOOD STRETCHER. FOR STRENGTH, TWO PIECES OF WOOD COMPRISE THE LEGS. SLIGHTLY ROUNDED EDGES CONTRIBUTION ADDITIONAL SMOOTHNESS TO THE COMPOSITION.

**DIMENSIONS**  
44"W x 22"L x 28"H

**PICTURED**  
OYSTER WAXED OAK

**WOOD FINISHES**

**SIGNATURE**

OAK  
BLACK INKED  
OXIDIZED  
OYSTER WAXED

**DISTINCTIVE**

FIGURED BLACK WALNUT  
BRILLIANT POLISH  
DANISH OIL  
OLD GROWTH WHITE OAK  
SOAP  
MAPLE  
OXIDIZED

**DIMENSIONS**

44"W x 22"L x 28"H

