

ROMAN AND WILLIAMS
GUILD
NEW YORK
ORIGINAL DESIGNS

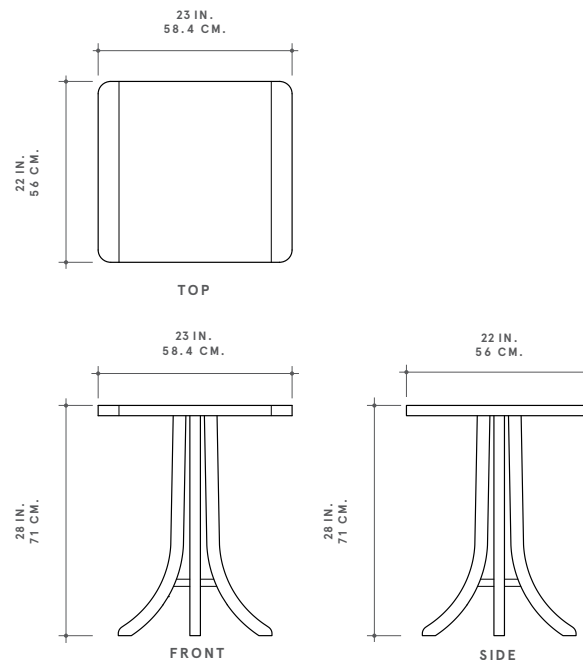

ROMAN AND WILLIAMS GUILD ORIGINAL DESIGNS
ANGELICA FOR TWO

ANGELICA IS WHERE FLUIDITY MEETS MASTER WOODWORKING. REFINED AND WELL-EDITED FEATURING A SUBSTANTIAL, THICK TOP WITH BREADBOARD ENDS THAT HOLD THREE FINE PIECES OF WOOD WITH FLUSH SEAMS. MORTISED, SOLID WOOD, CURVED LEGS UNITE WITH A WOOD BRACKET AND JOIN A WOOD STRETCHER. FOR STRENGTH, TWO PIECES OF WOOD COMPRISE THE LEGS. SLIGHTLY ROUNDED EDGES CONTRIBUTION ADDITIONAL SMOOTHNESS TO THE COMPOSITION.

DIMENSIONS
23"W x 22"L x 28"H

PICTURED
SOAPED OLD GROWTH WHITE OAK

WOOD FINISHES

SIGNATURE

OAK
BLACK INKED
OXIDIZED
OYSTER WAXED

DISTINCTIVE

FIGURED BLACK WALNUT
BRILLIANT POLISH
DANISH OIL
OLD GROWTH WHITE OAK
SOAP
MAPLE
OXIDIZED

DIMENSIONS

23"W x 22"L x 28"H

