

ROMAN AND WILLIAMS
GUILD
 NEW YORK
 ORIGINAL DESIGNS

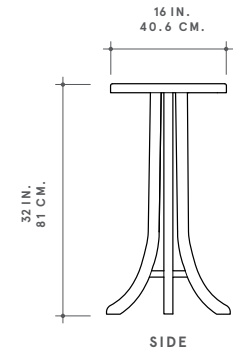
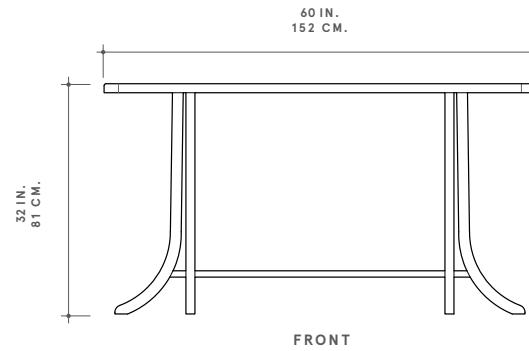
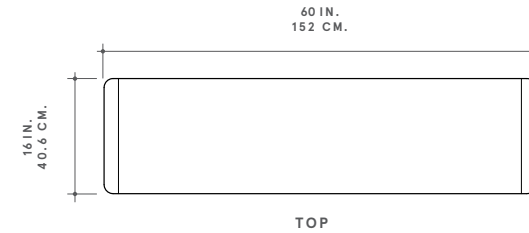

ROMAN AND WILLIAMS GUILD ORIGINAL DESIGNS
ANGELICA CONSOLE

ANGELICA IS WHERE FLUIDITY MEETS MASTER WOODWORKING. REFINED AND WELL-EDITED FEATURING A SUBSTANTIAL, THICK TOP WITH BREADBOARD ENDS THAT HOLD THREE FINE PIECES OF WOOD WITH FLUSH SEAMS. MORTISED, SOLID WOOD, CURVED LEGS UNITE WITH A WOOD BRACKET AND JOIN A WOOD STRETCHER. FOR STRENGTH, TWO PIECES OF WOOD COMPRISE THE LEGS. SLIGHTLY ROUNDED EDGES CONTRIBUTION ADDITIONAL SMOOTHNESS TO THE COMPOSITION. OUR CONSOLES ARE VERSATILE WITH MANY USES, ENTRYWAY, DESK, HOME BAR, SIDEBOARD, TV STAND, AND MORE.

DIMENSIONS
 60"W x 16"L x 32"H

PICTURED
 SOAPED OLD GROWTH WHITE OAK

WOOD FINISHES

SIGNATURE

OAK
 BLACK INKED
 OXIDIZED
 OYSTER WAXED

DISTINCTIVE

FIGURED BLACK WALNUT
 BRILLIANT POLISH
 DANISH OIL
 OLD GROWTH WHITE OAK
 SOAP
 MAPLE
 OXIDIZED

DIMENSIONS

60"W x 16"L x 32"H

