

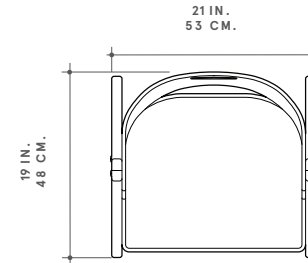

ROMAN AND WILLIAMS  
**GUILD**  
 NEW YORK

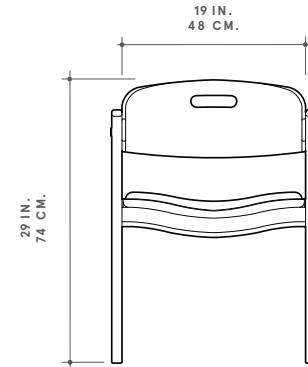

TOP



FRONT

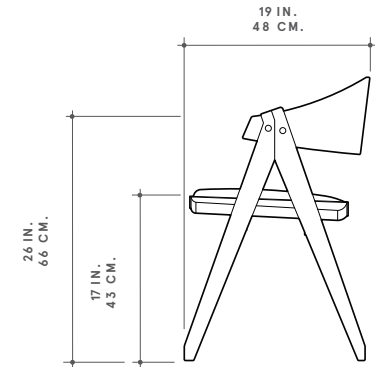

SIDE

**SOFT JACQUES**

On point, fancy French. Moving. Sturdy cup undercarriage supported by pencil-tapered legs that meet in an acute, incisive V. A complete reimagining of a 1950's French Art Deco metal chair by *Jacques Adnet*. We love cutouts: hole in the seatback is so you can yank it from dining table to desk.

*Jacques* was first prototyped for Upland restaurant in New York City. Available in two styles: leather or fabric-clad seat and more casual all wood.

**PICTURED** Teak in Medium Polish, Burnished Brass, Black Leather

**WOOD FINISHES**

**SIGNATURE**  
**WALNUT**

- Matte Oil
- Medium Polish
- Brilliant Polish

**RED OAK**  
 Bleached

- WHITE OAK**  
 Grey Stained
- Black Inked
- Waxed

- ASH**  
 Black Inked

- DISTINCTIVE**  
**CLARO WALNUT**  
 Matte Oil
- Medium Polish
- Brilliant Polish

- TEAK**  
 Matte Oil

- OLD GROWTH**  
**WHITE OAK**  
 Soap

**METAL FINISHES**

**SIGNATURE**

- Burnished Brass
- Dark Brass
- Blackened Brass
- Burnished Nickel

**DISTINCTIVE**

- Polished Bronze
- Rose Gold
- Silver
- Pewter

**GUILD FABRICS & LEATHERS**

Available in a variety of discerning fabrics and leathers.

**DIMENSIONS**

21"W × 29.5"H × 19.75"D