

**L760-Series
L8622/L9622-Series
Home and Commercial Treadmill
Diagnostic and Service Manual
2006
Addendum
Version C 1.0**

Table of Contents

Page 3	Upright Exploded View
Page 4	Upright Close-Up View
Page 5	L760 Bed
Page 6	L860/L960 Bed
Page 7	Motor Pan
Page 8-11	Parts List
Page 12-13	Upper Consoles
Page 14-15	Safety Key & Reading Rack Assembly Instructions
Page 16-18	Cardio Trainer upper board assembly instructions and schematic
Page 19-21	Executive Trainer upper board assembly instructions and schematic
Page 22-23	ANTA/PWM Schematic
Page 24-28	Error Codes message and definition
Page 29-32	Anta/PWM Flowchart
Page 33	Overspeed topic
Page 34	ANTA/PWM speed calibration
Page 35-40	ESI Reverse Treadmill
Page 41-44	Reverse Treadmill (RTM) Flowchart
Page 45	Reverse Treadmill (RTM) Speed Calibration
Page 46	Diagnostic Features
Page 47	Speed Formulas
Page 48	Elevation Calibration
Page 49	L9 Elevation nut setting
Page 50	Accessing Total hours and Mileage
Page 51-52	English to Metric Mode
Page 53-54	Button Feedback and Membrane by pass test
Page 55-61	L8622/L9622 Treadmill replacement
Page 62	Pro-Rate Table
Page 63	Service Reimbursement Policy and Labor Policy
Page 64	Service Authorization Form
Page 65	Maintenance Checklist

L60 Series, Upright

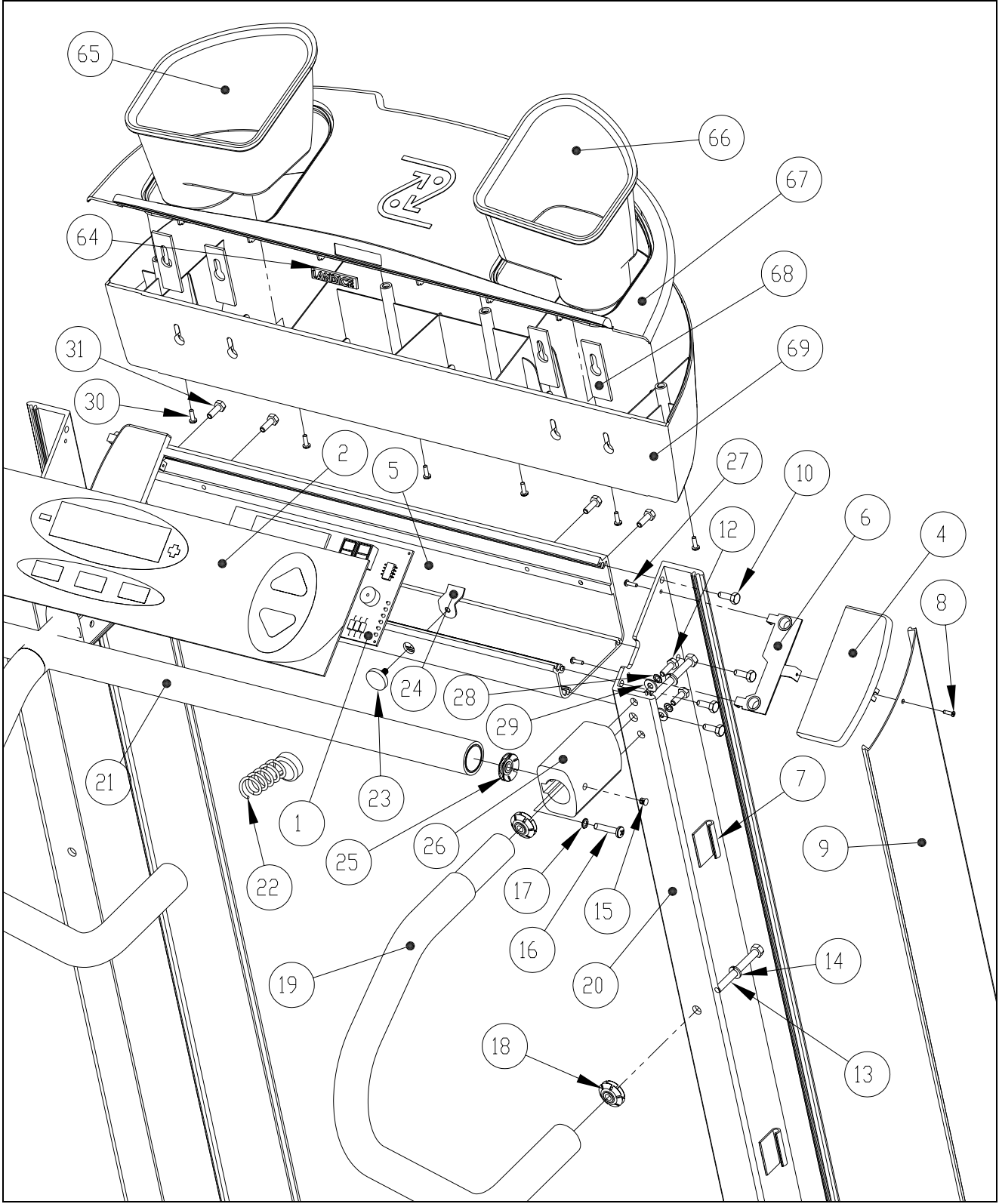

Handrail close-up view

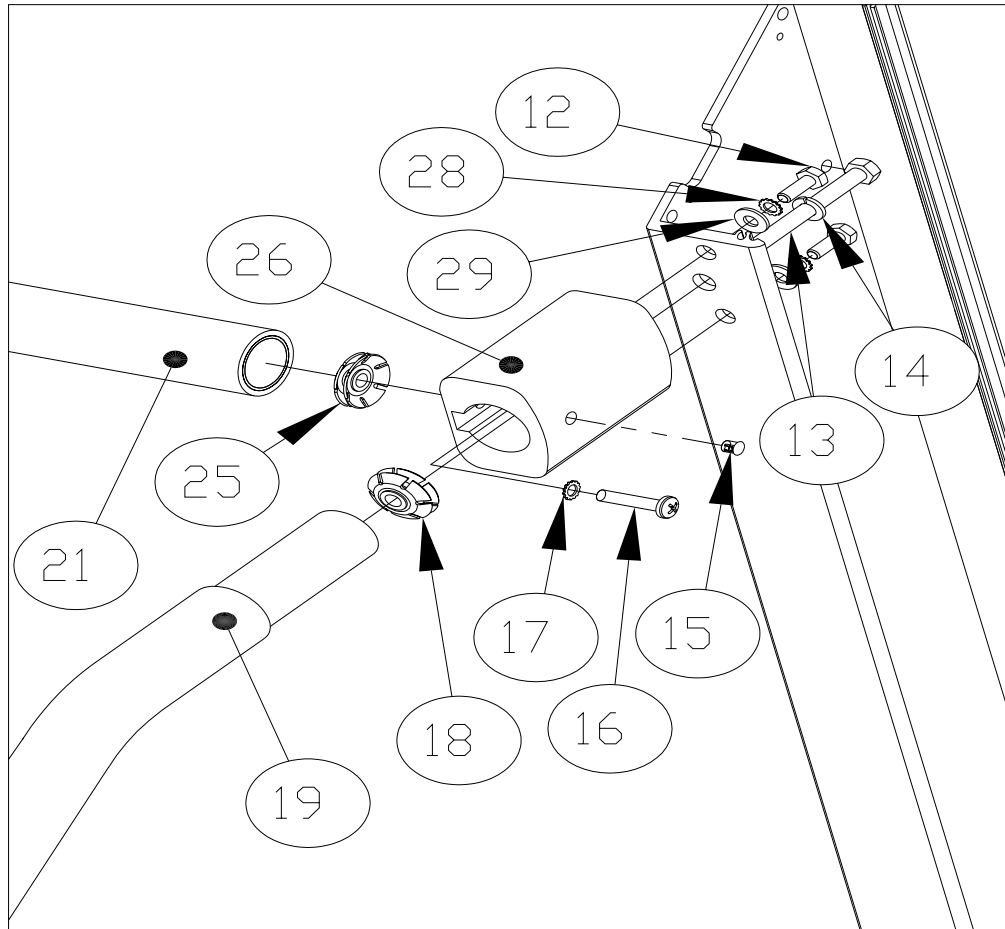

L-Series, L7 BED

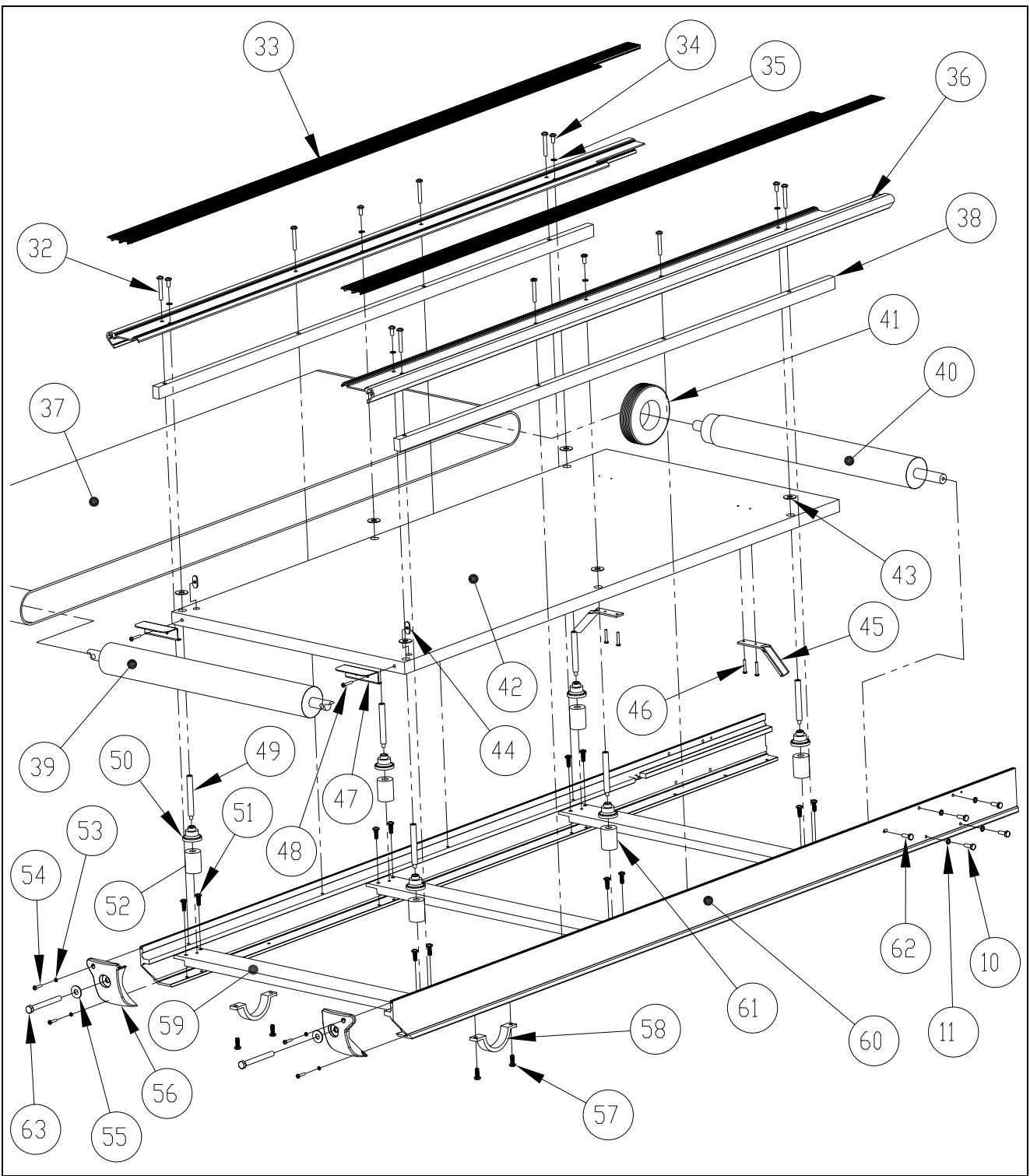

L-Series, L8 BED

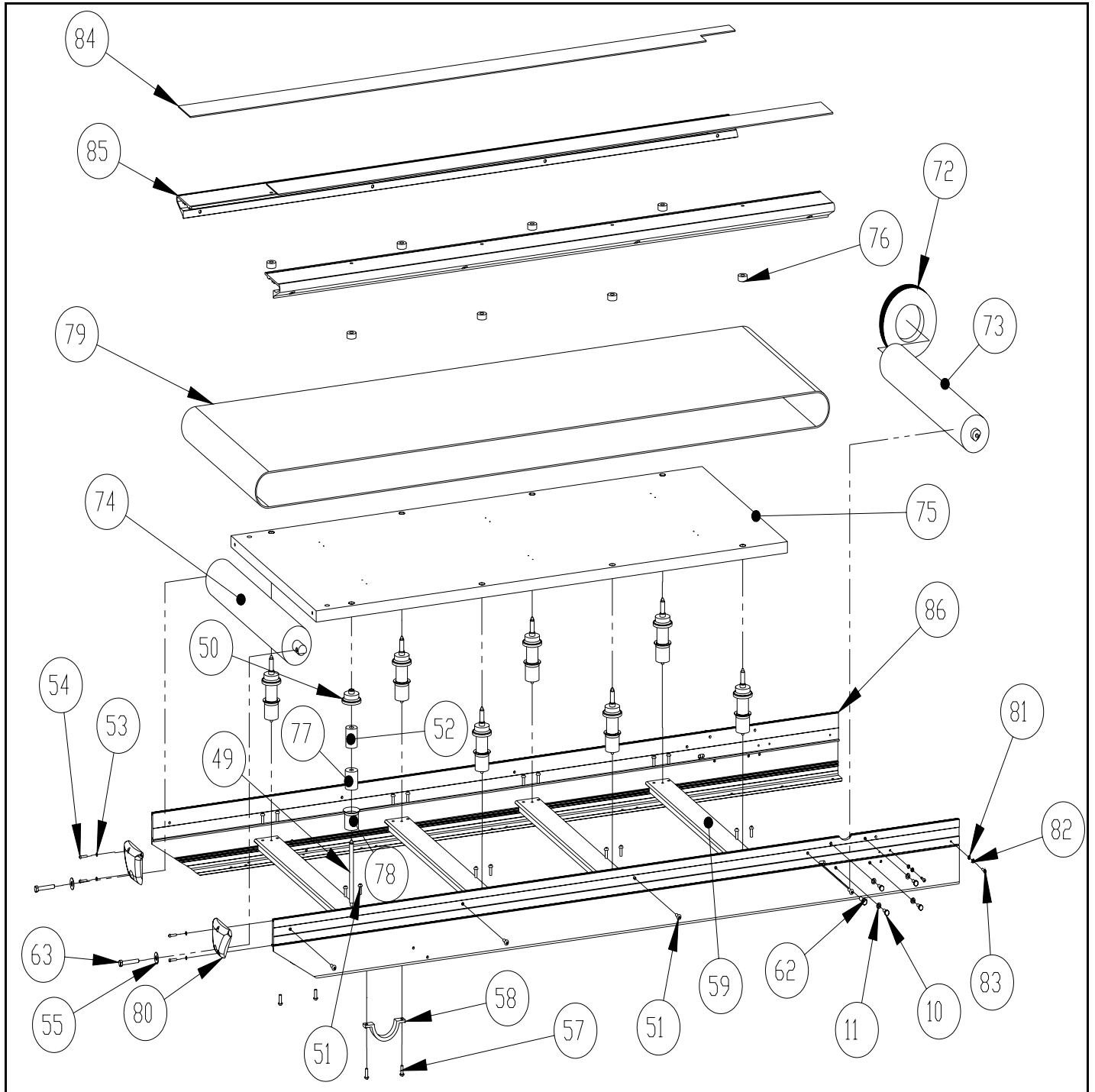

L-SERIES, MOTOR PAN

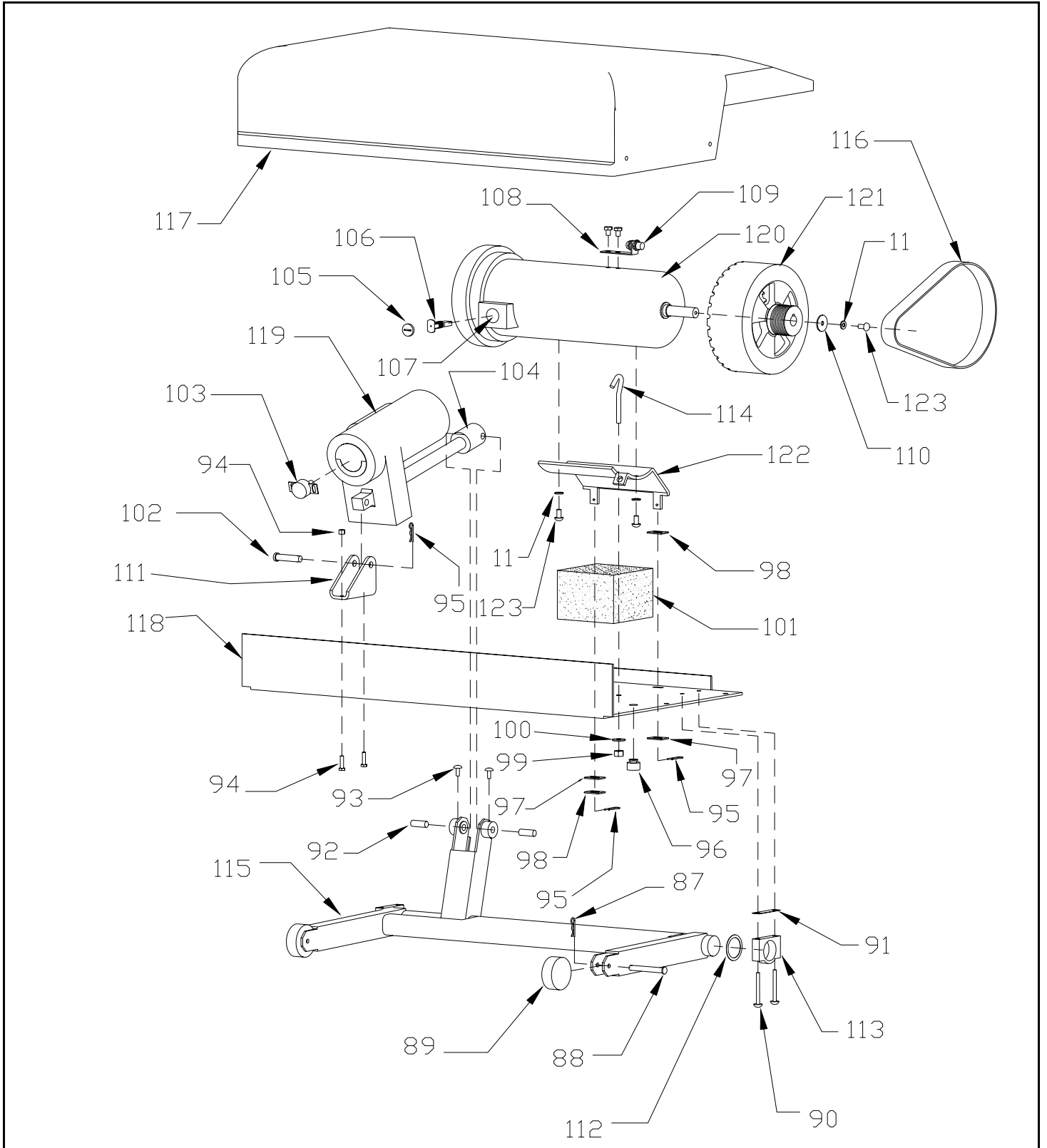



111 Canfield Avenue • Randolph, New Jersey 07869 • 1-800-LANDICE • FAX 973-927-0630

Parts List for Exploded View L7 & L8 Treadmills

Note: Always get Version number for electronic components to insure compatibility.

NUMBER	MODEL	DESCRIPTION	PART NUMBER
1	L7/L8/L9	DISPLAY BOARD – PRO SPORTS TRAINER	70424
		DISPLAY BOARD – CARDIO TRAINER (LCD)	70481
		DISPLAY BOARD – EXECUTIVE TRAINER (COLOR)	70478
2	L7/L8/L9	FACEPLATE – PRO SPORTS TRAINER 2	70484
		MEMBRANE PANEL – CARDIO TRAINER (LCD)	70482
		MEMBRANE PANEL – EXECUTIVE TRAINER (LCD)	70479
3	L7/L8/L9	READING RACK, CADDY, ASSEMBLY	70522-SP (-BK, TI)
4	L7/L8/L9	CONTROL PANEL END CAP, RIGHT	70246-BK (-TI)
		CONTROL PANEL END CAP, LEFT	70247-BK (-TI)
5	L7/L8/L9	CONTROL PANEL	70441-BK (-TI)
6	L7/L8/L9	CONTROL PANEL END CAP BRACKET ASSEMBLY (LEFT)	70316
		CONTROL PANEL END CAP BRACKET ASSEMBLY (RIGHT)	70315
7	L7/L8/L9	WIRE RETAINER, UPRIGHT	70349
8	L7/L8/L9	ENDCAP SCREW, BLACK (1/2")	6-32 1/2 PFHMSB
		ENDCAP SCREW, WHITE (1/2")	6-32 1/2 PFM
		ENDCAP SCREW, TITANIUM	6-32X1/2 PMSZN
9	L7/L8/L9	UPRIGHT COVER – LEFT (BLACK)	70231-BK
		UPRIGHT COVER – RIGHT (BLACK)	70230-BK
		UPRIGHT COVER – LEFT (WHITE)	70231-TI
		UPRIGHT COVER – RIGHT (WHITE)	70230-TI
10	L7/L8/L9	UPRIGHT MOUNTING BOLTS	1/4-20x3/4 TTZ
11	L7/L8/L9	STAR WASHER	1/4 LW EXT
12	L7/L8/L9	CROSSBAR CLAMP MOUNTING BOLT	1/4-20x3/4 HHMS
13	L7/L8/L9	HANDRAIL MOUNTING BOLT	5/16-18x2 HHMS
14	L7/L8/L9	LOCKWASHER	5/16 LW
15	L7/L8/L9	1/4 INCH DOME PLUG	71071
16	L7/L8/L9	CROSSBAR MOUNTING BOLT	1/4-20 1.25 PMS
17	L7/L8/L9	STAR WASHER	1/4 LW EXT
18	L7/L8/L9	RAM CONNECTOR 1 1/4" DIA. TUBE (HANDRAIL)	71038
19	L7/L8/L9	SIDE ERGO RAIL ASSEMBLY WITH FOAM CUTBACK	71063
20	L7/L8/L9	UPRIGHT, RIGHT SIDE, (BLACK)	70474-BK
		UPRIGHT, LEFT SIDE, (BLACK)	70475-BK
		UPRIGHT, RIGHT SIDE, (TITANIUM)	70474-TI
		UPRIGHT, LEFT SIDE, (TITANIUM)	70475-TI
		UPRIGHT, RIGHT SIDE, (WHITE)	70474
		UPRIGHT, LEFT SIDE, (WHITE)	70475

21	L7/L8/L9	ACCUTRACK C.H.R. CROSSBAR ASSEMBLY 2 (or 3)	70445-SP
		CROSSBAR W/ FOAM, L-SERIES	70341
22	L7/L8/L9	MAGNETIC SAFETY LANYARD	71011-NEW
23	L7/L8/L9	MAGNETIC STUD	70492
24	L7/L8/L9	FLUX GUIDE	70340
25	L7/L8	RAM CONNECTOR, 1/12" DIA. TUBE (CROSSBAR)	71070
26	L7/L8	CROSSBAR/HANDRAIL MOUNTING CLAMP	70461
27	L7/L8	END CAP BRACKET MOUNTING SCREW	8-32 1/2 MSZ
28	L7/L8/L9	WASHER – FENDER	¼ LW EXT
29	L7/L8/L9	FLAT WASHER STAINLESS STEEL	¼ FW SAE
30	L7/L8/L9	READING RACK COVER SCREW	8x1/2 A PPSTSZN
31	L7/L8/L9	READING RACK CONSOLE SCREW	1/4-20x3/4 HHMS
32	L7	DECK SCREWS	¼-20 1.3/4 TTZ
33	L7	TRACTION STRIP (SPECIFY LEFT OR RIGHT)	70469
34	L7	VFX POST SCREW	¼-20 9/16 MSZN
35	L7	STAR WASHER	¼ LW EXT
36	L7	SIDE FRAME COVER, RIGHT	70464 (-BK, -TI)
		SIDE FRAME COVER, LEFT	70465 (-BK, -TI)
37	L7	L760, TREADBELT	70468
		L760, TREADBELT ORTHO	70534
38	L7	DECK SPACER	70219
39	L7	TAKE UP ROLLER	70237
40	L7	DRIVE ROLLER	70236
41	L7	DRIVE ROLLER SHEAVE	CV-18-2
42	L7	L760 – DECK	70466
43	L7/L8/L9	FELT WASHER	70220
44	L7	¼ NUT	¼-20 WELD NUT
45	L7/L8/L9	BELT GUIDE	70208
46	L7/L8/L9	BELT GUIDE SCREW	8x1 A PPSTS ZN
47	L7/L8/L9	SAFETY BRACKET	70204
48	L7/L8/L9	SAFETY BRACKETNUT	¼-20 WELD NUT
49	L7	VFX DECK POST , L7	70216
	L8/L9	VFX DECK POST, L8	70297
50	L7/L8/L9	VFX DECK LOAD WASHER	70217
51	L7/L8/L9	DECK SLAT SCREWS AND L8 FRAME SCREWS	¼-20 3/4 TTZ
52	L7/L8/L9	VFX DECK IMPACT ABSORBER	70221
		VFX DECK IMPACT ABSORBER, RED	70221-R
53	L7/L8/L9	#8 ZINC LOCK WASHER	8 LW
54	L7/L8/L9	BED END CAP SCREW	8-32 3/4 TTB
55	L7/L8/L9	TAKE UP ROLLER BOLT WASHER	3/8 FW BL OX
56	L7	END CAP, BED, RIGHT	70369 (-BK)
		END CAP, BED, LEFT	70370 (-BK)
57	L7/L8/L9	FOOTBOLT	¼-20 3/4 TTZ
58	L7/L8	SOLID FOOT	70008
	L9	FOOT – L9	70421
59	L7/L8/L9	VFX DECK SLAT	70240
60	L7/L8/L9	L760 - SIDE FRAME, RIGHT	70462 (-BK, -TI)
		L760- SIDE FRAME, LEFT	70463 (-BK, -TI)
61	L7/L8/L9	VFX DECK IMPACT ABSORBER, RED	70221-R
62	L7	DRIVE ROLLER SCREW	¼-20x3/4 HWFL

63	L7/L8/L9	TAKE UP ROLLER BOLT	3023
64	L7/L8/L9	NAMEPLATE, READING RACK	70454
65	L7/L8/L9	LEFT, READING RACK BUCKET	70522-BUCKETL
66	L7/L8/L9	RIGHT, READING RACK BUCKET	70522-BUCKETR
67	L7/L8/L9	TOP, READING RACK	70522-TOP
68	L7/L8/L9	KEYHOLE PLATE, READING RACK	70522-KEYHOLE
69	L7/L8/L9	BOTTOM, READING RACK	70522-BOTTOM

71	L7/L8/L9	UPRIGHT CONTROL PANEL FRAME SCREW	¼-20x3/4 TT
72	L8/L9	SHEAVE, DRIVE ROLLER, L8	70290
73	L8/L9	DRIVE ROLLER,L8622	70504
74	L8/L9	TAKE-UP ROLLER,L8622	70505
75	L8/L9	DECK,L8/9,22"	70296
76	L8/L9	FELT WASHER, L8622	70516
77	L8/L9	SPACER, 8622	70506
78	L8/L9	SLEEVE, SPACER, L8622	70515
79	L8/L9	TREADBELT, L8622	70513
		TREADBELT, L8622 ORTHO	70535
80	L8/L9	END CAP, BED, BLACK, L8622-RIGHT	70508-BK
		END CAP, BED, BLACK, L8622-LEFT	70509-BK
81	L7/L8/L9	RUBBER MOTOR COVER GROMMENT	1259
82	L7/L8/L9	MOTOR COVER FINISHING WASHER	10 Finishing_W
83	L7/L8/L9	MOTOR COVER SCREW	8-32 3/4 TTB
84	L8/L9	TREADSTRIP (PEGGLY GRIP TAPE)	70293
85	L8/L9	SIDE FRAME COVER, RIGHT	70286 (-BK, -TI, -RR)
		SIDE FRAME COVER, LEFT	70287 (-BK, -TI, -RR)
86	L8/L9	SIDE FRAME RIGHT, L8622	70510 (-BK, -TI)
		SIDE FRAME LEFT, L8622	70511 (-BK, -TI)
87	L7/L8/L9	HITCH PIN FOR AXLE, WIDE	213
88	L7/L8/L9	WHEEL AXLE, WIDE	70359
89	L7/L8/L9	WHEEL, WIDE	70358
90	L7/L8/L9	BEARING BLOCK BOLT	¼-20 2 MSZ
91	L7/L8/L9	BEARING BLOCK SPACER, WIDE	70403
92	L7/L8/L9	ELEVATION PIN	70032
93	L7/L8/L9	ELEVATION PIN SCREWS	¼-20 9/16 MSZN
94	L7/L8/L9	CLEVIS BOLT HARDWARE	70345
95	L7/L8/L9	HITCH PIN(MOTOR BRACKET AND CLEVIS)	233
96	L7/L8/L9	ELEVATION LEG RUBBER BUMPER	2215
97	L7/L8/L9	MOUTOR MOUNT SPACER, RUBBER	70090
98	L7/L8/L9	MOUTOR MOUNT SPACER, METAL	70089
99	L7/L8/L9	TENSION SCREW NUT	¼-20 NUT
100	L7/L8/L9	TENSION SCREW FLAT WASHER	1/4 SHOULDER_W
101	L7/L8/L9	FOAM BLOCK	70103
102	L7/L8/L9	CLEVIS PIN	70063
103	L7/L8/L9	ELEVATION POTENTIOMETER	71013
104	L7/L8/L9	ELEVATION NUT	MISC
105	L7/L8/L9	MOTOR BRUSH CAP	MISC
106	L7/L8/L9	MOTOR BRUSH, 110V	70222
		MOTOR BRUSH, 220V	70223
107	L7/L8/L9	MOTOR BRUSH HOLDER	MISC

108	L7/L8/L9	SPEED SENSOR BRACKET	70067
109	L7/L8/L9	SPEED SENSOR	71007
110	L7/L8/L9	FLYWHEEL FLAT WASHER	¼ FENDER W
111	L7/L8/L9	ELEVATION CLEVIS	70049
112	L7/L8/L9	BEARING BLOCK WASHER, WIDE	70402
113	L7/L8/L9	BEARING BLOCK, WIDE (SINGLE PIECE)	70373
114	L7/L8/L9	TENSION SCREW	70071
115	L7	ELEVATION LEG ASSEMBLY, WIDE	70367
	L8/L9	ELEVATION LEG ASSEMBLY, WIDE	70374
116	L7	DRIVE BELT, L760	220J10
	L8/L9	DRIVE BELT, L860	70291
117	L7	MOTOR COVER AERO, L760	70520-SP
	L8/L9	MOTOR COVER, L860	70523-20-SP
	L8/L9	MOTOR COVER AERO, L8622 & L9622	70523-SP
118	L7/L8/L9	MOTOR PAN	70373
119	L7/L8/L9	ELEVATION MOTOR W/ POTENTIOMETER, 110V	70088-C-SP
		ELEVATION MOTOR W/ POTENTIOMETER, 220V	70126-SP
120	L7/L8/L9	DRIVE MOTOR, 110V	70014
		DRIVE MOTOR, 220V	70125
121	L7/L8/L9	FLYWHEEL	70010
122	L7/L8/L9	MOTOR BRACKET	70071
		MOTOR BRACKET, L8622	70507
123	L7/L8/L9	MOTOR BRACKET SCREWS	1/4-20 9/16 MSZ

Series Pro Sports Trainer Faceplate

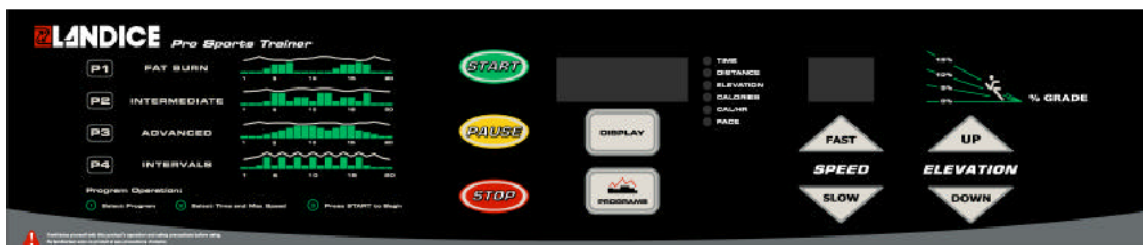

Models That Use This Faceplate:

L7-PST, L8-PST, L7-LTD-PST, L8-LTD-PST, L7-CLUB-PST, L8-CLUB-PST, L9-CLUB-PST.

Production Time Frame: 2003-Present

Electronics: : PWM/Relay Combo motor pan on all Home Units, 110V SCR commercial motor pan for LTD's and 110V CLUB's, 220V SCR commercial motor pan for 220V CLUB units. See Wiring Diagrams.

Settings Used In: Home and Commercial (LTD's and CLUB's)

Key Features: Closed Loop Treadmill (w/ speed sensor), Safety Lanyard, 0.5-12MPH Push Button Speed and Elevation Control (11MPH on LTD's and CLUB's), 4 Built in Programs, 2 User Defined Programs.

L-Series Cardio Trainer LCD Membrane

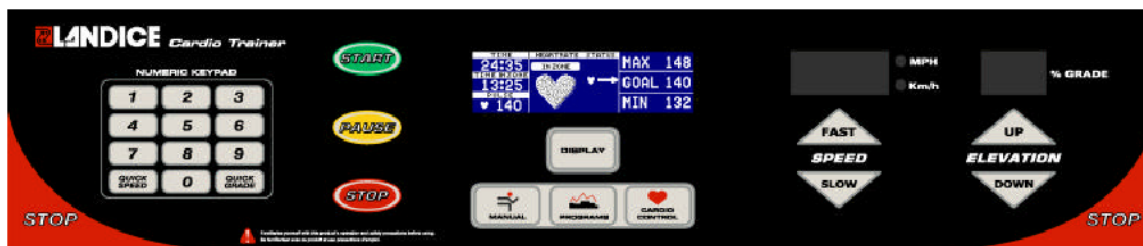

Models That Use This Membrane:

L7-CT, L8-CT, L7-LTD-CT, L8-LTD-CT, L7-CLUB-CT, L8-CLUB-CT. L9-CLUB-CT.

Production Time Frame: 2003-Present

Electronics: PWM/Relay Combo motor pan on all Home Units, 110V SCR commercial motor pan for LTD's and 110V CLUB's, 220V SCR commercial motor pan for 220V CLUB units. See Wiring Diagrams.

Settings Used In: Home and Commercial (LTD's and CLUB's)

Key Features: Closed Loop Treadmill (w/ speed sensor), Safety Lanyard, 0.5-12MPH Push Button Speed and Elevation Control (11MPH on LTD's and CLUB's), 5 Built in Programs, 5 User Defined Programs, Standard Wireless Heart-Rate Control, Two Color LCD Graphic Display, Numeric Keypad with Quick Speed and Quick Grade Features, Touch Sensitive STOP switches on both left and right side, Optional ACCUTRAK Contact Heart Rate System on CLUB units.

L-Series Color Executive Trainer Membrane



Models That Use This Membrane:

L7-ET, L8-ET, L7-LTD-ET, L8-LTD-ET, L7-CLUB-ET, L8-CLUB-ET, L9-CLUB-ET.

Production Time Frame: 2003 – Present

Electronics: PWM/Relay Combo motor pan on all Home Units, 110V SCR commercial motor pan for LTD's and 110V CLUB's, 220V SCR commercial motor pan for 220V CLUB units. See Wiring Diagrams.

Settings Used In: Home and Commercial (LTD's and CLUB's)

Key Features: Closed Loop Treadmill (w/ speed sensor), Safety Lanyard, 0.5-12MPH Push Button Speed and Elevation Control (11MPH on LTD's and CLUB's), 5 Built in Programs, 5 User Defined Programs, Standard Wireless Heart-Rate Control, Color LCD Graphic Display, Numeric Keypad with Quick Speed and Quick Grade Features, Touch Sensitive STOP switches on both left and right side, Optional ACCUTRAK Contact Heart Rate System on CLUB units.

L-Series Reversing Rehabilitation Faceplate



Models That Use this Membrane

L7-RTM-REV, L8- RTM-REV, L9- RTM-REV

Production Time Frame: 2004- Present

Electronics: ESI PWM-R, 110V, 220v See Wiring Diagram

Settings Used In: Rehabilitation, Physical Therapy, and Hospitals

Key Features: Closed Loop Treadmill (w/ speed sensor), Safety Lanyard, Push Button Speed and Elevation Control, Isolation Leakage Package to keep current leakage under 100 micro-amps.

RTM: Moves in forward direction only, Speed range is from 0.0 to 12.0 mph in 0.1 mph increments, No reverse button on display panel, Optional Remove Start/Stop switch holder.

RTM-REV: Moves in forward and reverse direction, Standard remote start/stop switch holder, Speed range in forward direction is 0.0 to 12.0 mph in 0.1 increments. Speed range in reverse direction is 0.0 to 3.0 to 0.1 mph increment (slow scroll). Tracking is accomplished by use of reverse guide rollers. Production treadmills to have metal guide rollers then could change to plastic guide rollers. While belt is moving in reverse, treadbelt will move slightly until the reverse guide rollers activate. This treadmill is slightly louder due to our treadbelt guide system.. Reverse button on display panel has red reverse LED. The REVERSE button allows user to switch treadbelt direction from forward to reverse and vice versa. The Rehabilitation treadmill will run in reverse when Reverse button is pressed and red reverse light is illuminated.

L-SERIES MAGNETIC SAFETY KEY INSTALLATION

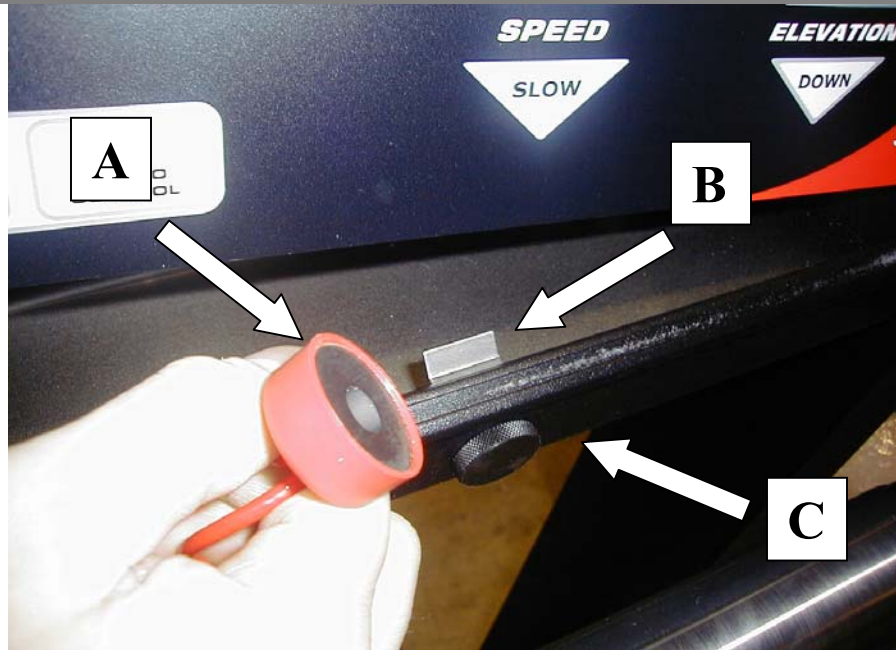

The magnetic safety key assembly consists of three parts.

- A. Magnetic safety key (part # 71011-SP)
- B. Flux Guide (part # 70340)
- C. Magnet Stud (part #70492)

To install this assembly into an older machine that utilized the Tree-Loc (ball & socket) attachment design proceed with the following steps:

1. UN PLUG TREADMILL
2. Remove control panel end caps and upper display assembly.
3. Remove the old style Tree-Loc socket.
4. Install new style magnet stud (B) by threading into the flux guide (A).
5. Make sure flux guide is positioned as shown in pictures.
6. Install new magnetic safety key.

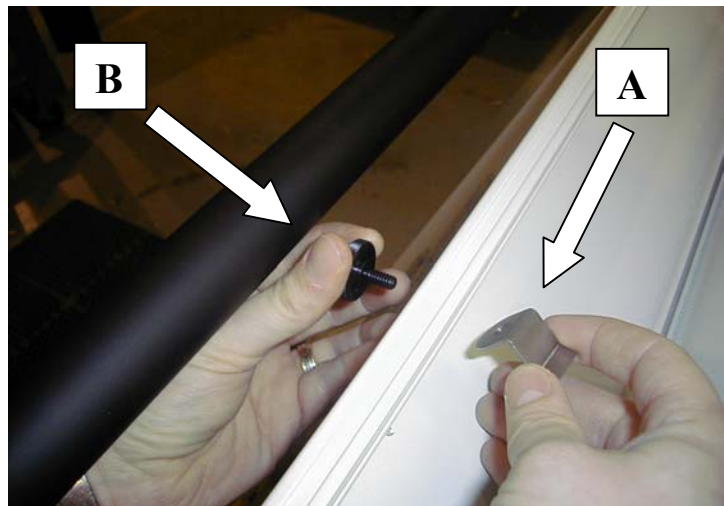

**CALL 1-800-LANDICE
FOR TECHNICAL ASSISTANCE**

READING RACK ASSEMBLY

1. Check back of control panel for (4) 7/16" hex head bolts. Make sure they are offset from surface by 1/2".

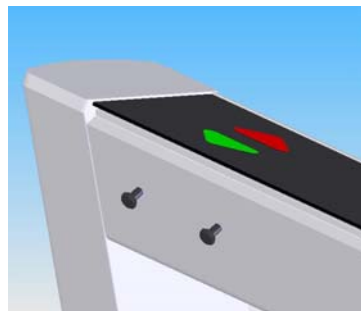

2. Align (4) bolts with back of reading rack and mount. After clearing the bolt heads, make sure the reading rack drops completely into place.

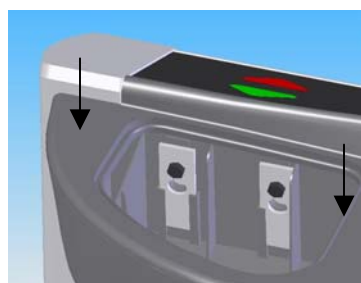

3. Prior to tightening the (4) bolts, check for proper alignment and fit around the display panel.

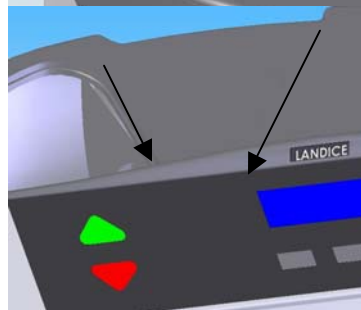

4. Using a 7/16" socket wrench, tighten the (4) bolts. Drop buckets into the reading rack.

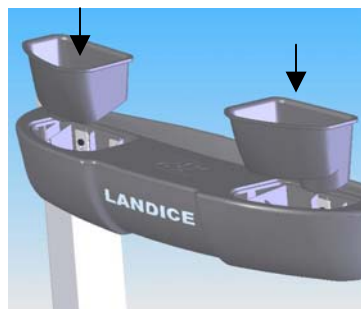

5. Using a phillips-head screw driver, gently fasten the buckets into position with (2) 1/2" inch wood screws (do not over tighten).

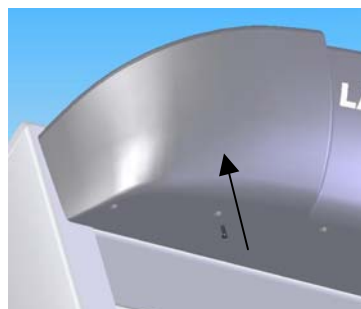

CT LCD Assembly Instructions



1) First lay the membrane face down. You should have the Velcro seal at top of membrane. (Be sure to place a towel underneath the membrane)



2) Next mount the LCD screen to the mounting studs on membrane panel. Secure LCD to panel by tightening the screws.



3) Next take the ribbon cable on and gently slide one corner in and push the other corner gently into the connector as shown above. Do this for both ribbon cables.

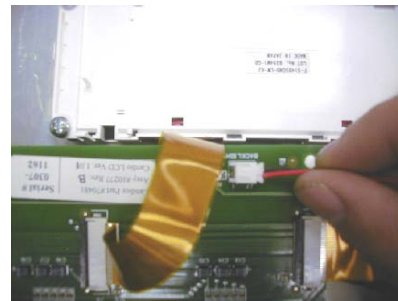

4) Next plug in the backlight from the LCD to the upper display board. This plug will only go in one way.



5) Next flip the upper board over and mount it to its holding pins. Once it's seated, screw it down to the mounting stud

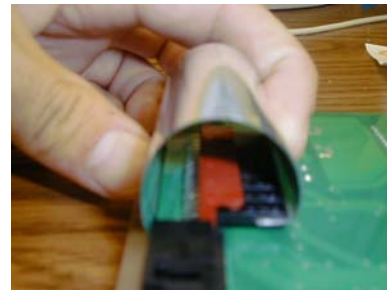

6) Finally loop ribbon cable over and plug into the back of the upper display board.

Cardio Trainer Upper Board Wire Diagram

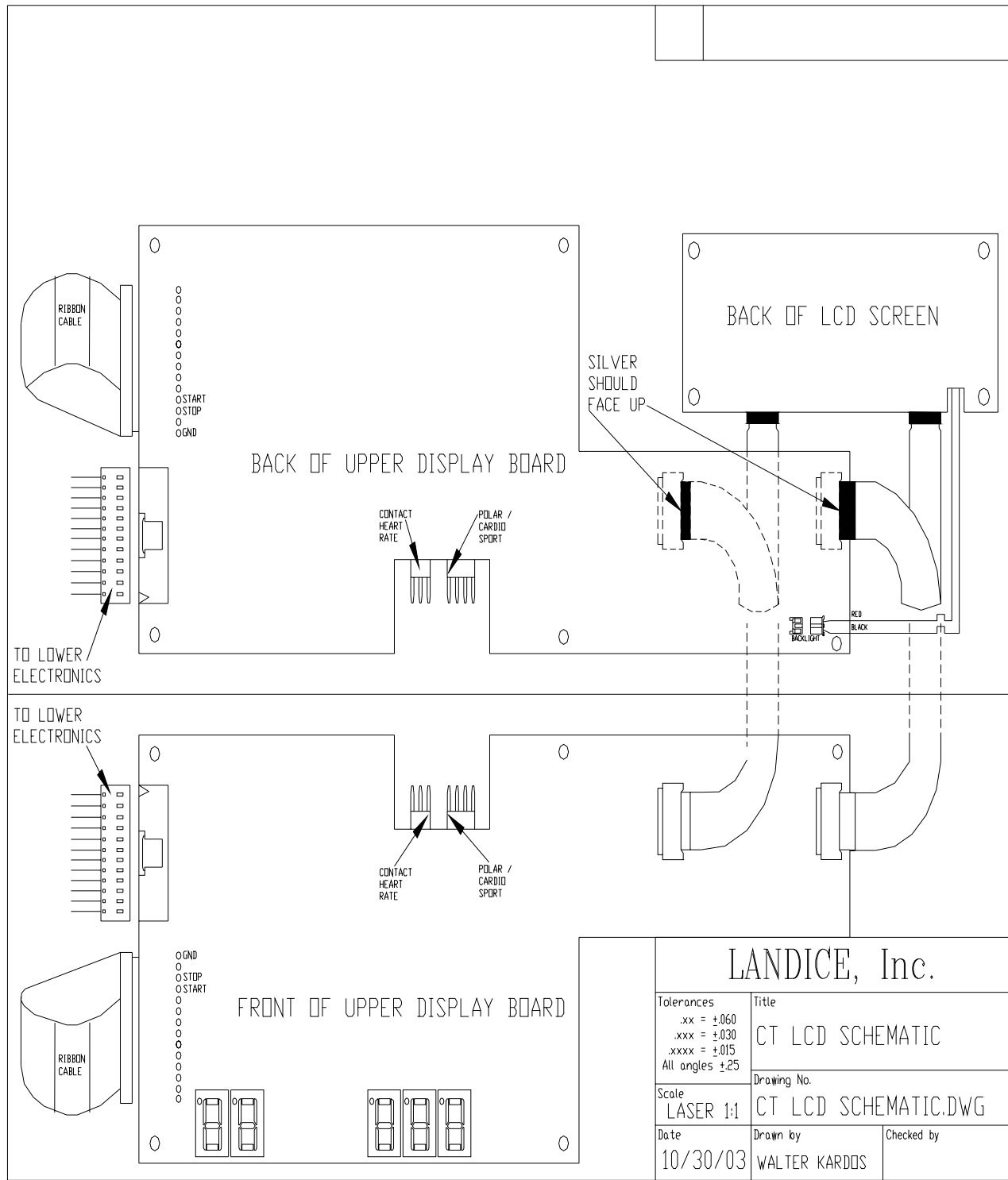

Cardio Trainer Upper Board Wire Diagram

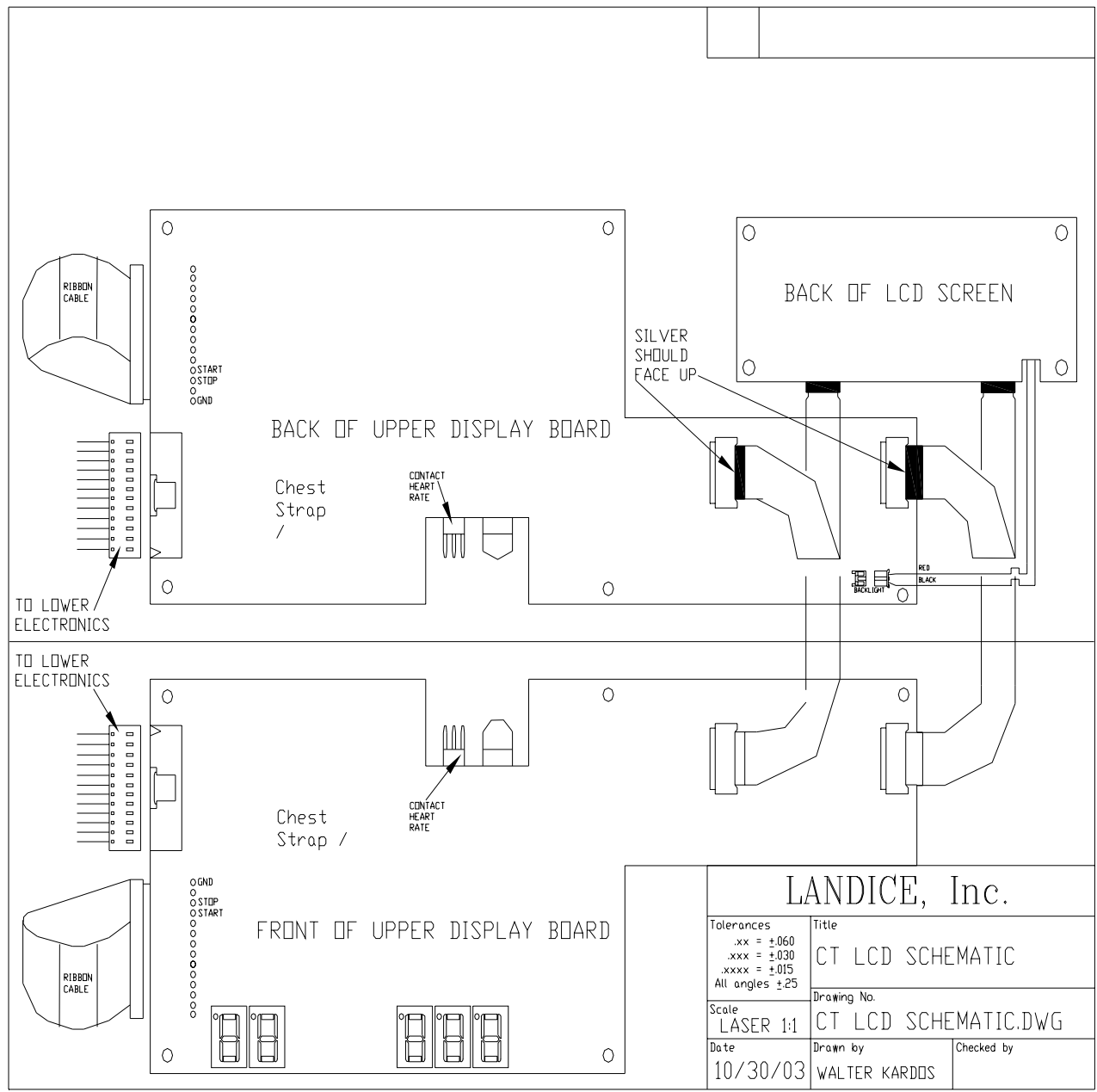

CT with single pulse connection

Color ET Assembly Instructions



1) First place the membrane on a flat surface with the back facing upwards. Place the membrane on a towel to prevent scratches

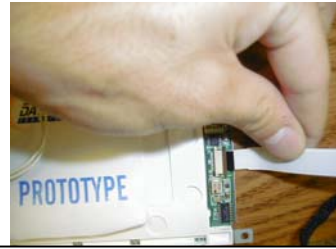

2) Next gently pull the brown clip out and gently slip the ribbon cable into the connector. Push brown clip back in.



3) Then mount the LCD screen to the mounting studs on the Membrane Panel by tightening the 4 screws

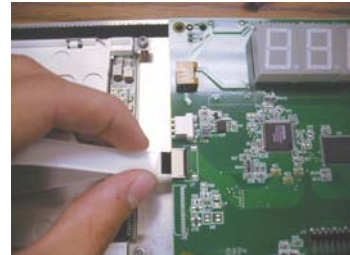

4) Next place the upper display board on the right side of the LCD screen and plug the other side of the ribbon connector into the upper board

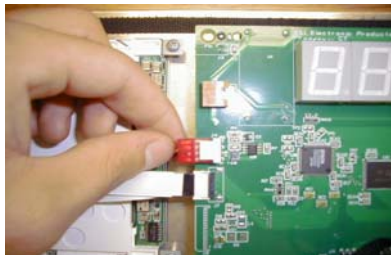

5) Next plug the H/R cable into the middle connector shown above. This plug goes in only one way.

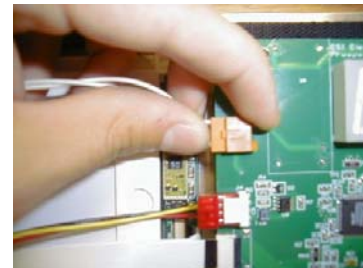

6) Next plug in the power supply cable from the LCD to the Upper board.



7) Next move the upper board face down to the left of the LCD screen. Tighten down display screws.



8) Loop the ribbon cable over and plug it into the upper display connector.

Executive Trainer Upper Board Wire Diagram

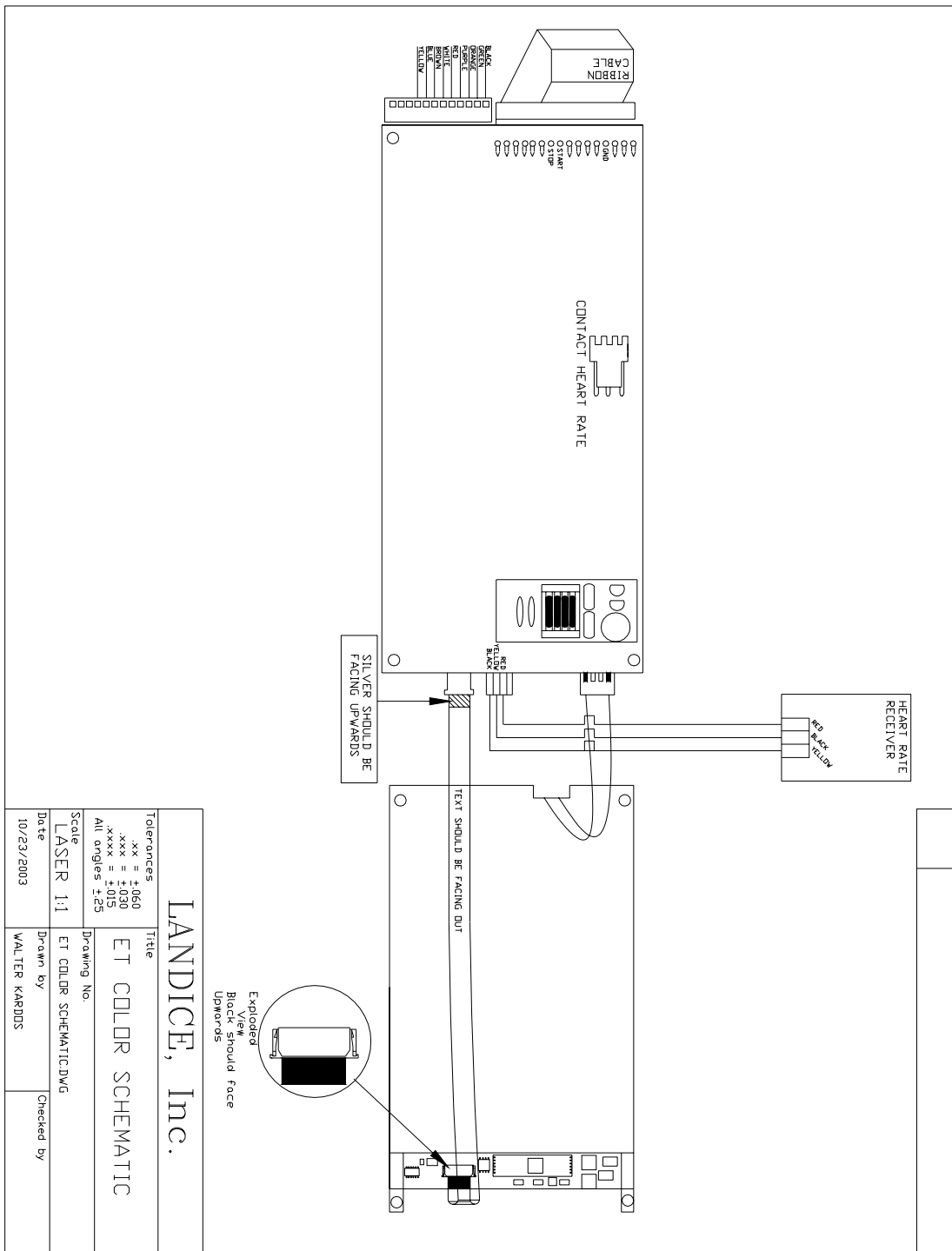

ET with pulse connection

Executive Trainer Upper Board Wire Diagram

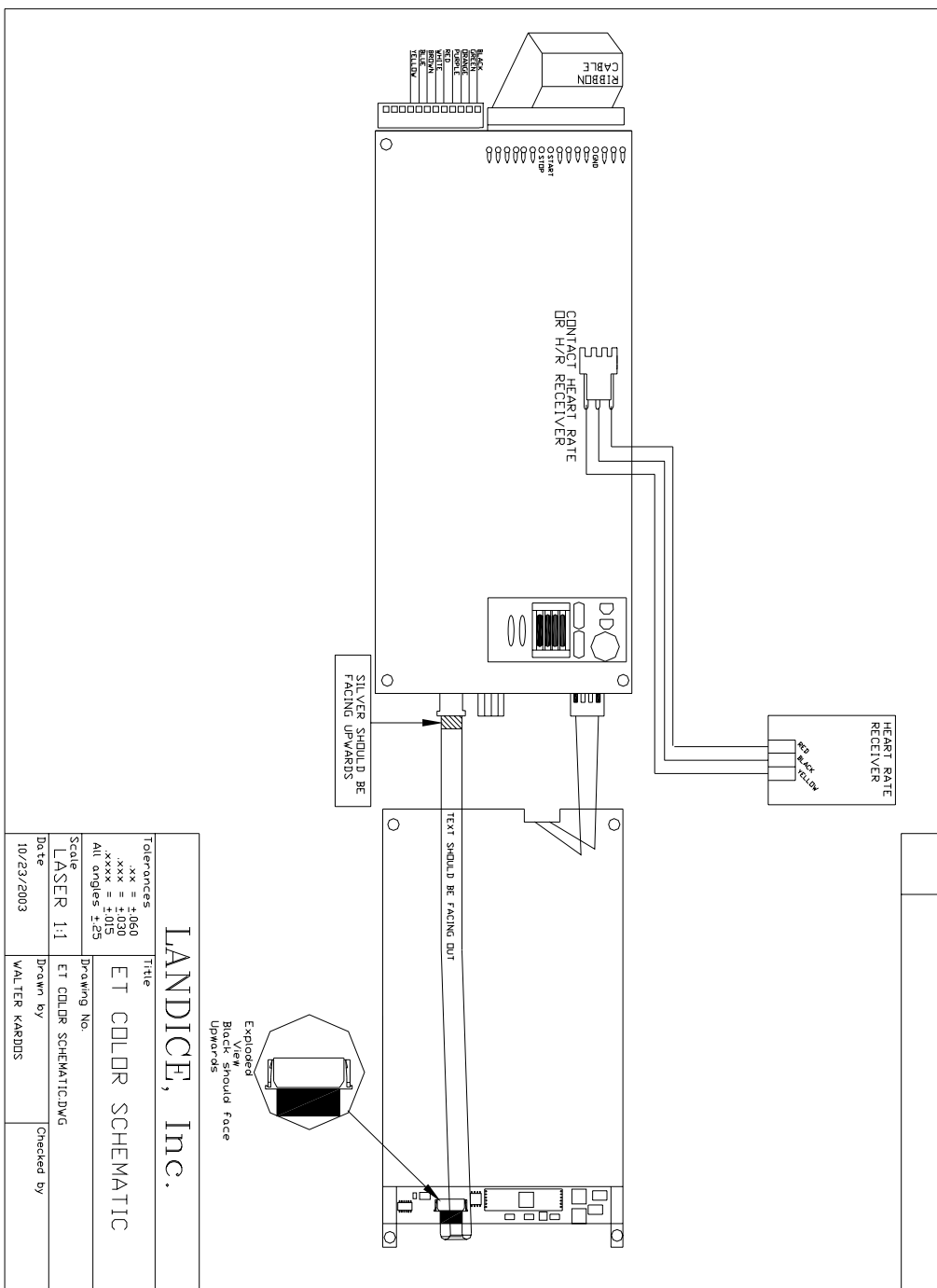

ET with single pulse connection 1

PWM MOTOR CONTROL BOARD W/ RELAY ASSEMBLY

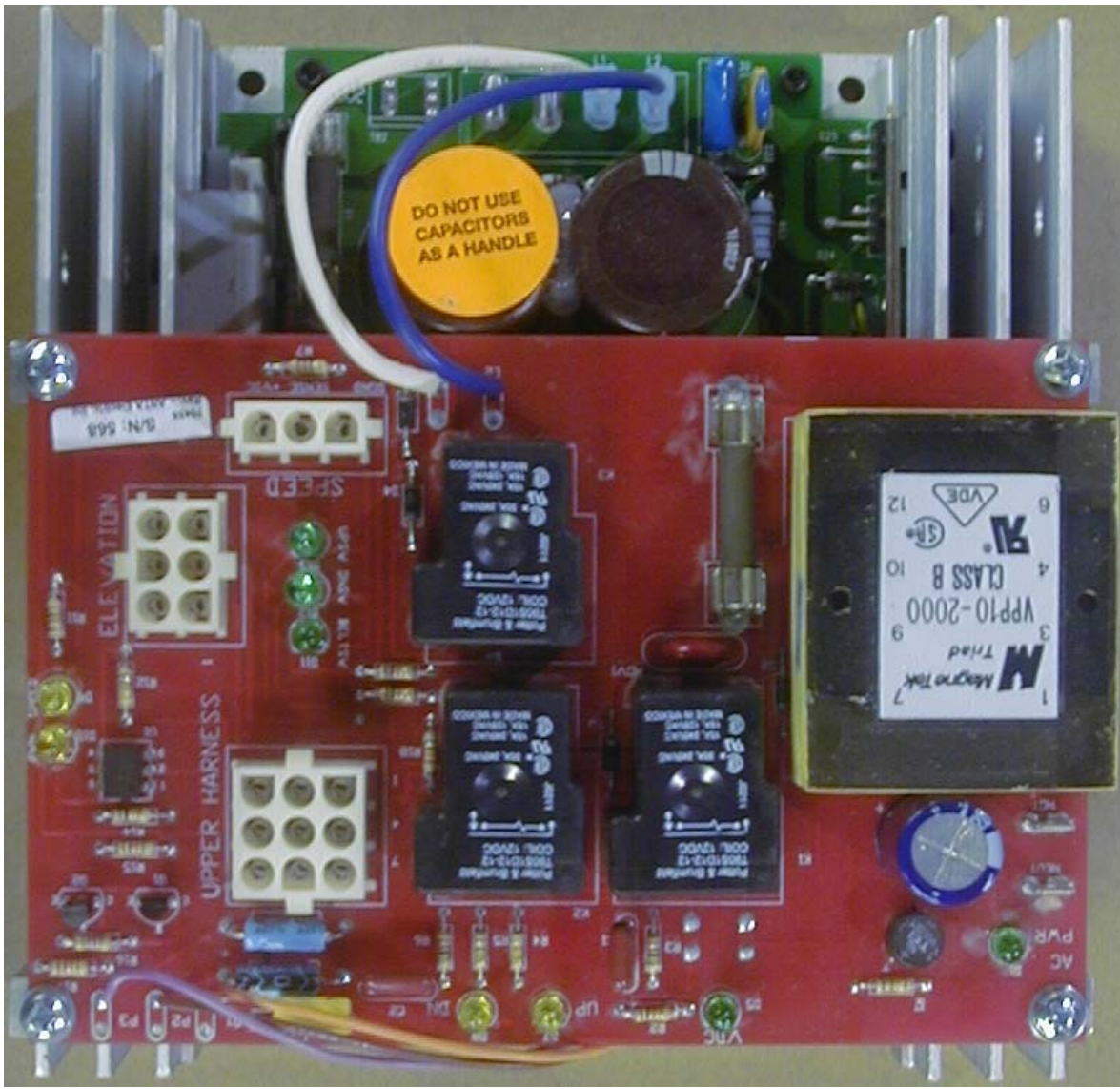

L60-SERIES HOME MOTOR PAN WIRING SCHEMATIC (PWM MOTOR CONTROL BOARD WITH RELAY ASSEMBLY)

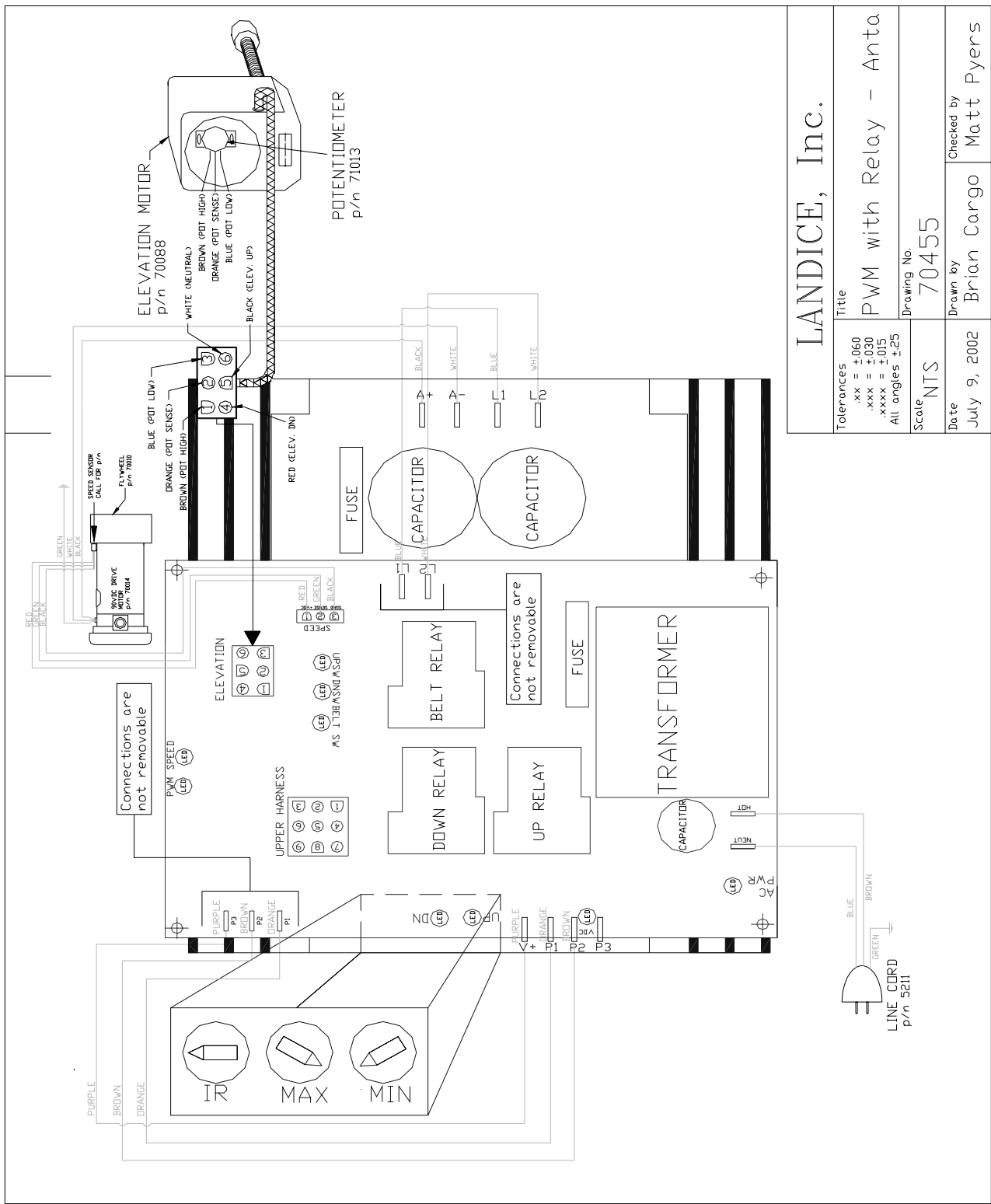

ERROR CODES SHOWN ON DISPLAY

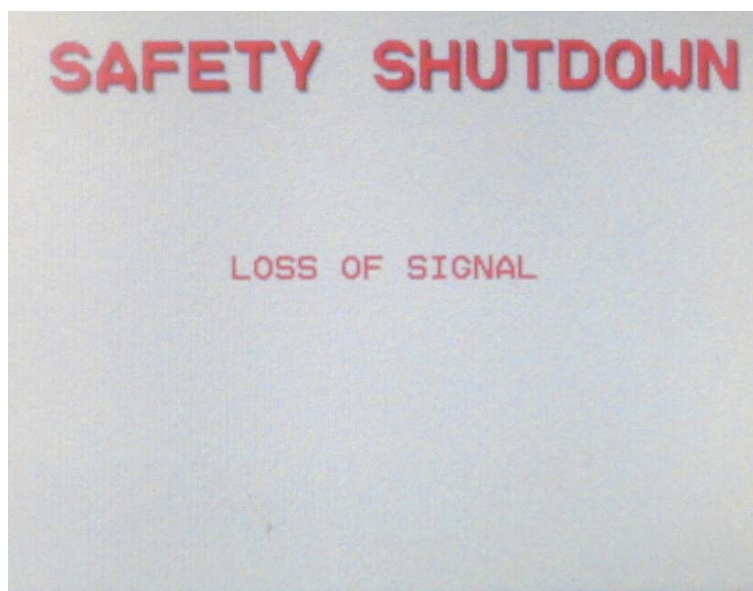

Error Code: Loss of Speed Signal WITH belt movement

Meaning: upper display is not receiving signal from the speed sensor

Diagnostics: Refer to diagnostic flowchart: “Upper display lights up; treadbelt moves; speed will not increase; L5 error”

Error Code: Loss of Speed Signal NO belt movement

Meaning: upper display not receiving signal from speed sensor because drive motor is not moving

Diagnostic: Refer to diagnostic flowchart: “Upper display lights up but treadbelt doesn’t move; L5 error “

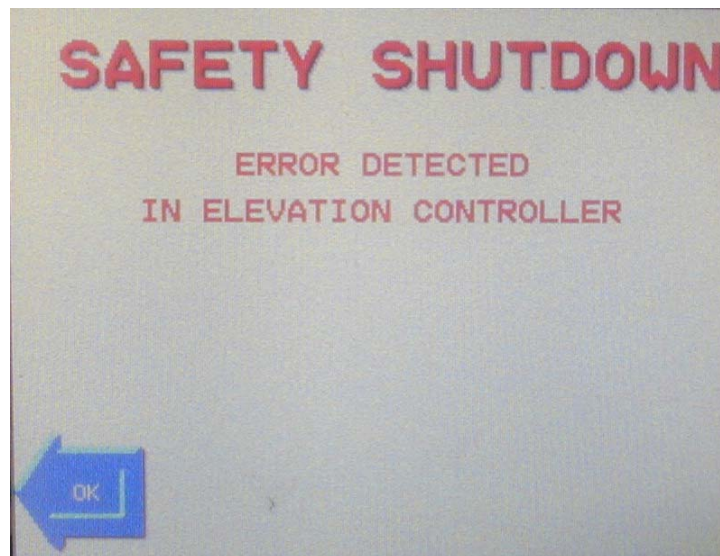

Error Code: Grade potentiometer out of range (PO error)

Meaning: error detected in the elevation system

Diagnostic: Refer to diagnostic flowchart: "Elevation system not functioning or PO error"

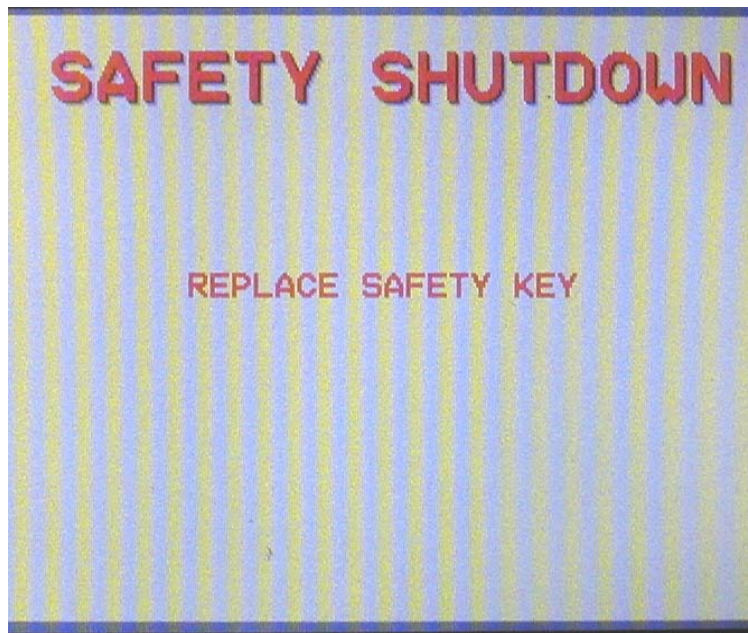

Error Code: Replace Safety Key

Meaning: Safety key is not recognize

Diagnostic: Replace safety key (see **Safety Key Installation**, page 14)

If problem persist replace upper display board

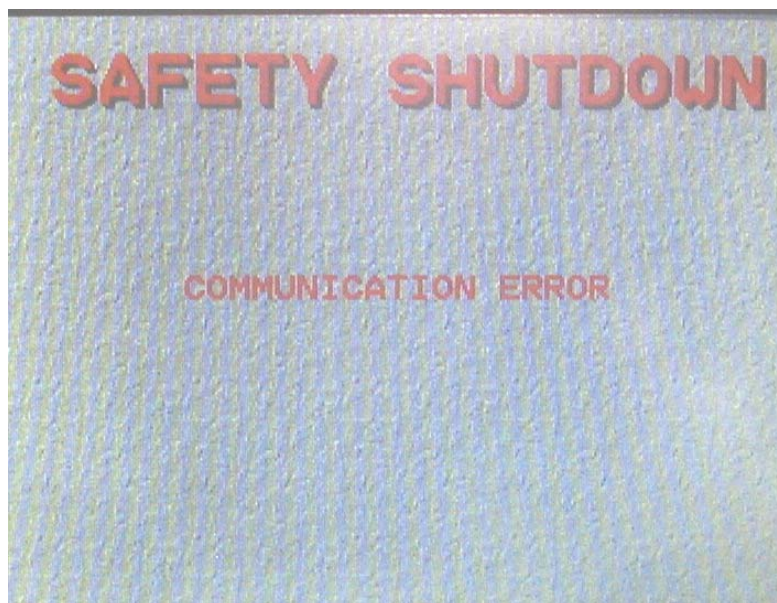
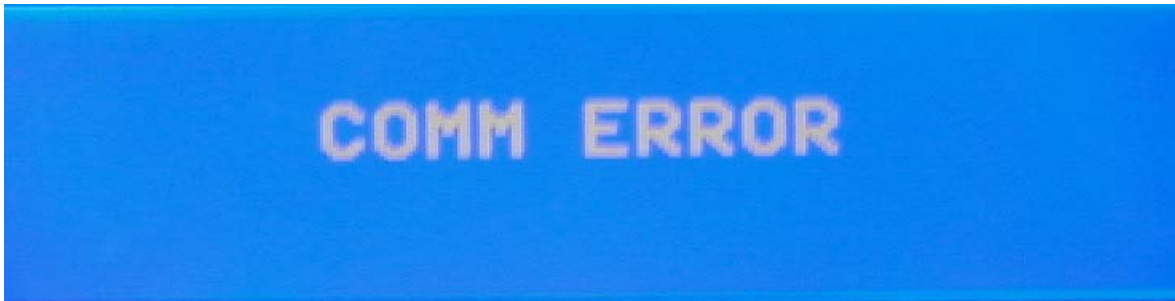

Error Code: Communication Error

Meaning: Upper display board is not communicating with the lower board

Diagnostic: Error can be a result to a upper/lower board failure or a upper wire harness problem.

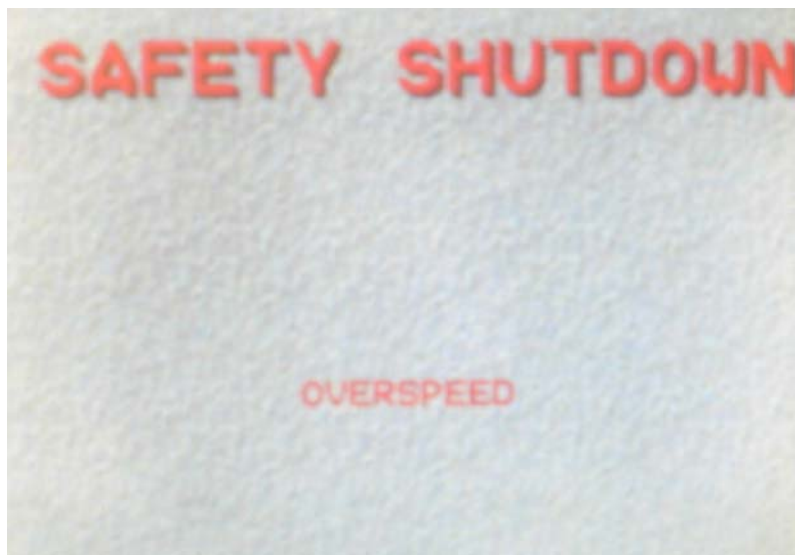
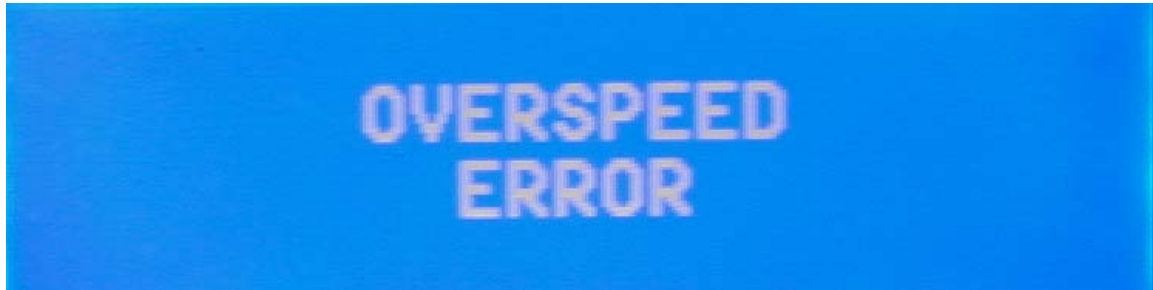

Error Code: Over Speed Error

Meaning: Treadmill speed is faster than the desired selected speed

Diagnostic: See page 33

NOTE: USE THIS FOR DIAGNOSING THE PWM/RELAY COMBO BOARD

Upper display lights up but treadbelt doesn't move: L5 Error

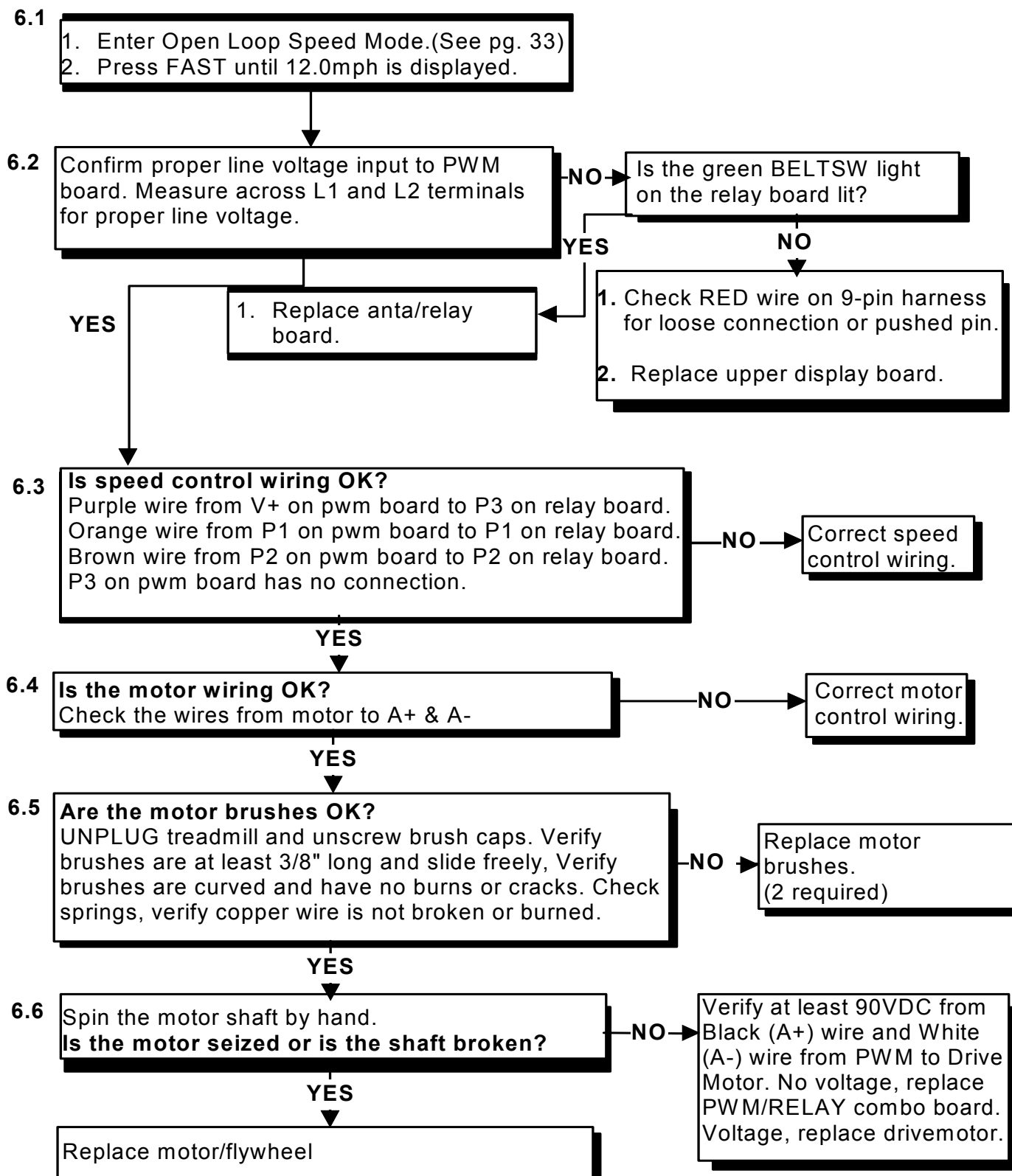

NOTE: USE THIS DIAGNOSING FOR THE PWM/RELAY COMBO BOARD
 Upper display lights up; treadbelt moves; speed will not increase; L5 error.

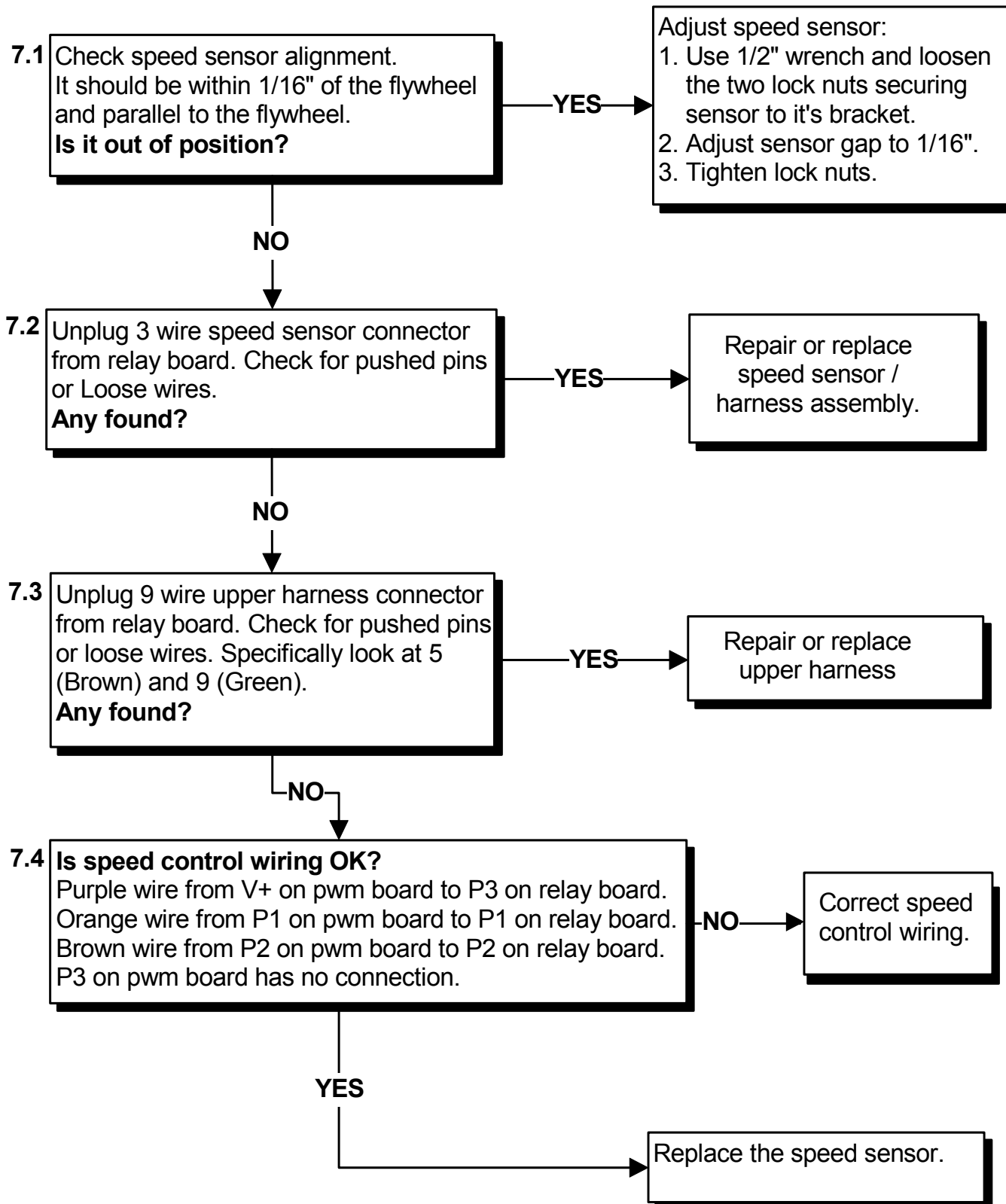

NOTE: USE THIS FOR DIAGNOSING THE PWM/RELAY COMBO BOARD

Upper display fails to light when START is pressed.

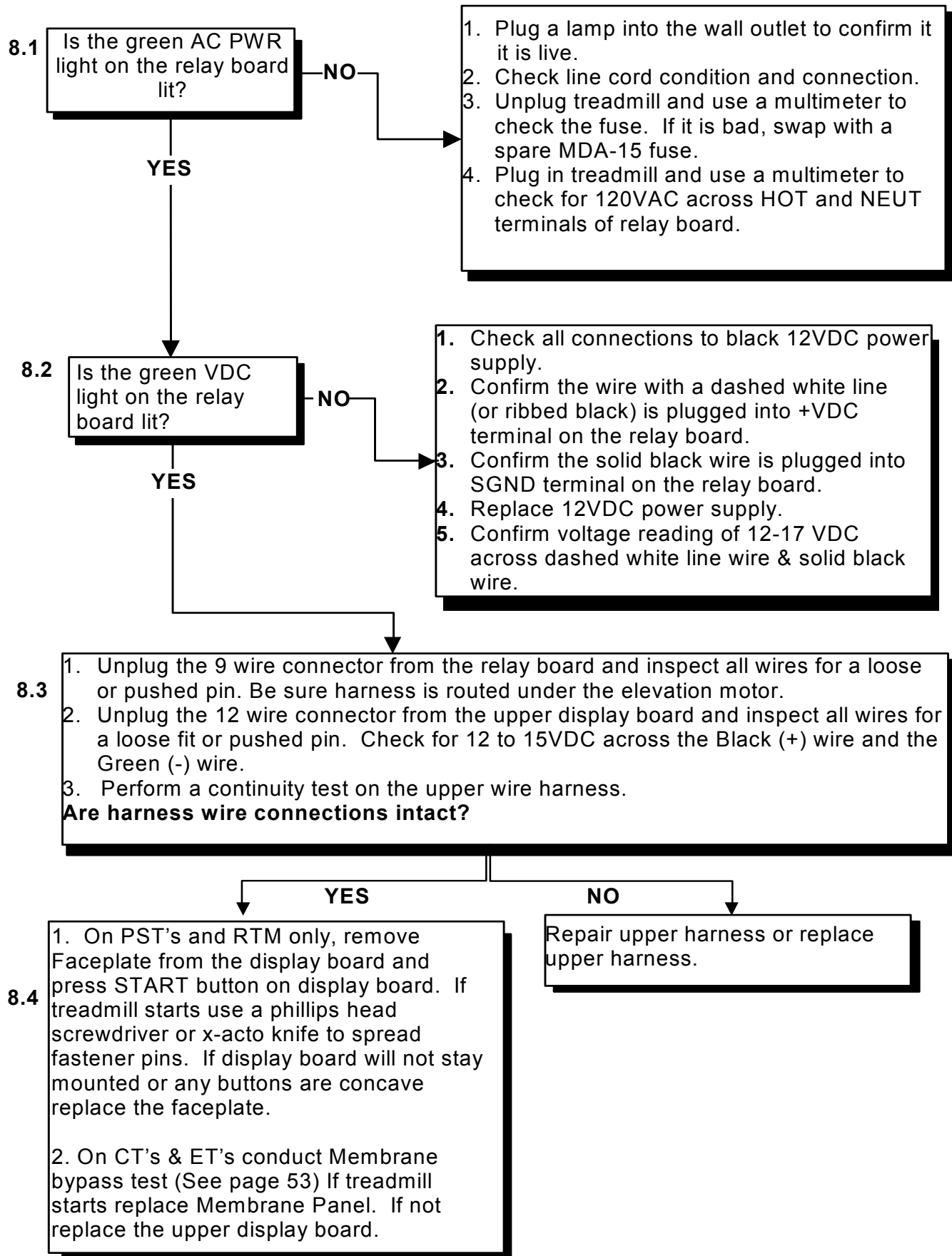

NOTE: USE THIS FOR DIAGNOSING THE PWM/RELAY COMBO BOARD
Elevation system not functioning or PO (Pot Out) error code displayed in the two digit speed window.

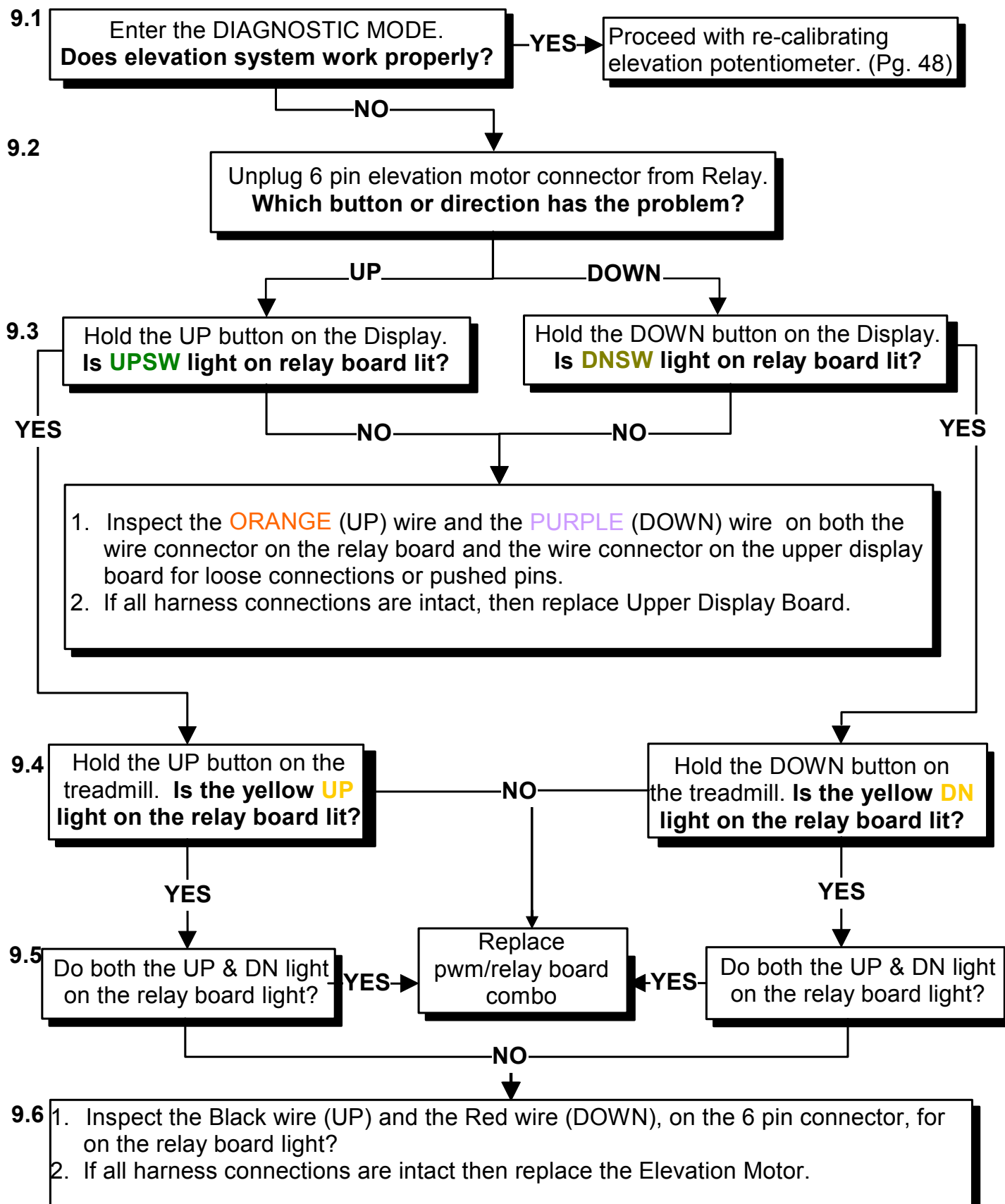

Overspeed

An overspeed error indicates a treadmill overspeed condition. This occurs when the actual treadbelt speed is faster than the desired selected speed. There is a potential for this to occur under the following circumstances:

- 1) User weight is over 200 lbs., treadmill elevation is set between 10% and 15% grade, and selected speed is set between .5 mph and 3.0
- 2) If user pushes against treadbelt causing it to go faster than speed set
- 3) Defective lower board or misaligned speed sensor
- 4) Maladjusted speed pot

Gravitational force will enable the user's weight to move the treadbelt faster. The speed sensor will pick up this increase in flywheel speed and send this information up to the display board electronics. The microprocessor will then compare the actual speed to the displayed speed, determine a runaway speed condition and shut the treadmill down. An **overspeed** will display in the window. This is a safety feature built into all treadmills that utilize our closed loop speed circuitry (all current production treadmills).

The only way to remedy an overspeed condition due to gravity is to have the user decrease the treadmill elevation under 10% grade, or increase the speed.

If the user is holding onto handrails and pushing the treadbelt (using it like a manual treadmill rather than a motorized one) it will cause an **overspeed error**.

Solution: Don't push on the treadbelt.

It's possible a blown motor control board is the problem. This occurs more frequently with PWM drives than SCR drives. However, this problem is becoming rare due to the PWM circuitry that senses this condition and shuts itself down before the drive motor receives any DC voltage at all. This means you'll get an LS or L5 error if your Anta/PWM or PWM is blown, not an **overspeed error**. This is a safety feature on all Landice home treadmills with an Anta/PWM or PWM motor control board. The SCR motor control boards also have internal protection to prevent an overspeed condition from occurring due to a internal component failure.

Overspeed can also be caused by a maladjusted speed pot. Go into Open Loop Speed mode (see page 26) and check the speed. Adjust pots as necessary to bring up correct speed.

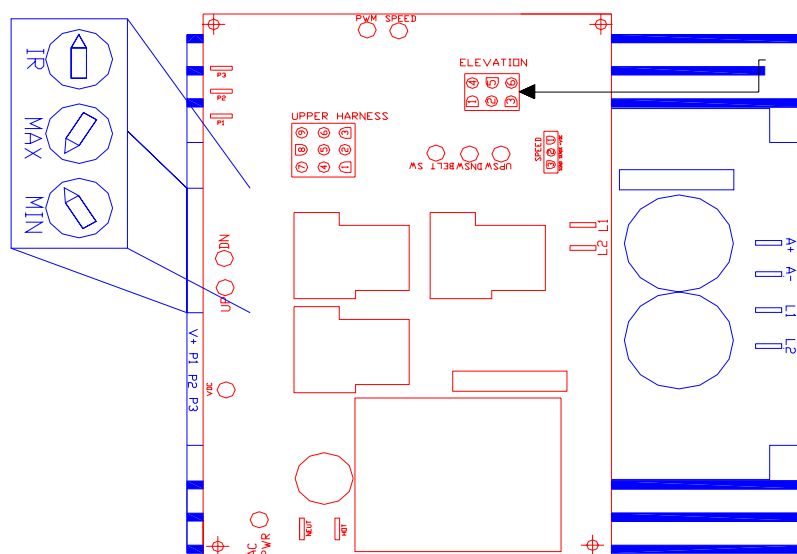

Speed Calibration: L-Series ANTA/PWM Treadmills

1. Enter into Open Loop Speed mode (O.L.S.) by pressing simultaneously

Executive Trainer

MENU & START

Cardio Trainer

DISPLAY & START

Pro Sport Trainer & RTM

FAST & START

2. Adjust the max speed first. Bring the set speed to 12mph. Let actual speed stabilize.
3. Adjust the MAX potentiometer on the pwm motor control board accordingly.

CW = increase speed / CCW = decrease speed.

The actual speed will be displayed in the center display window.

4. Decrease set speed to .5mph. Let actual speed stabilize. Adjust the MIN pot accordingly.
(.48 to .52mph is acceptable)
5. Before turning treadmill off, check the MAX speed one more time for accuracy.

ESI PWM-Reverse

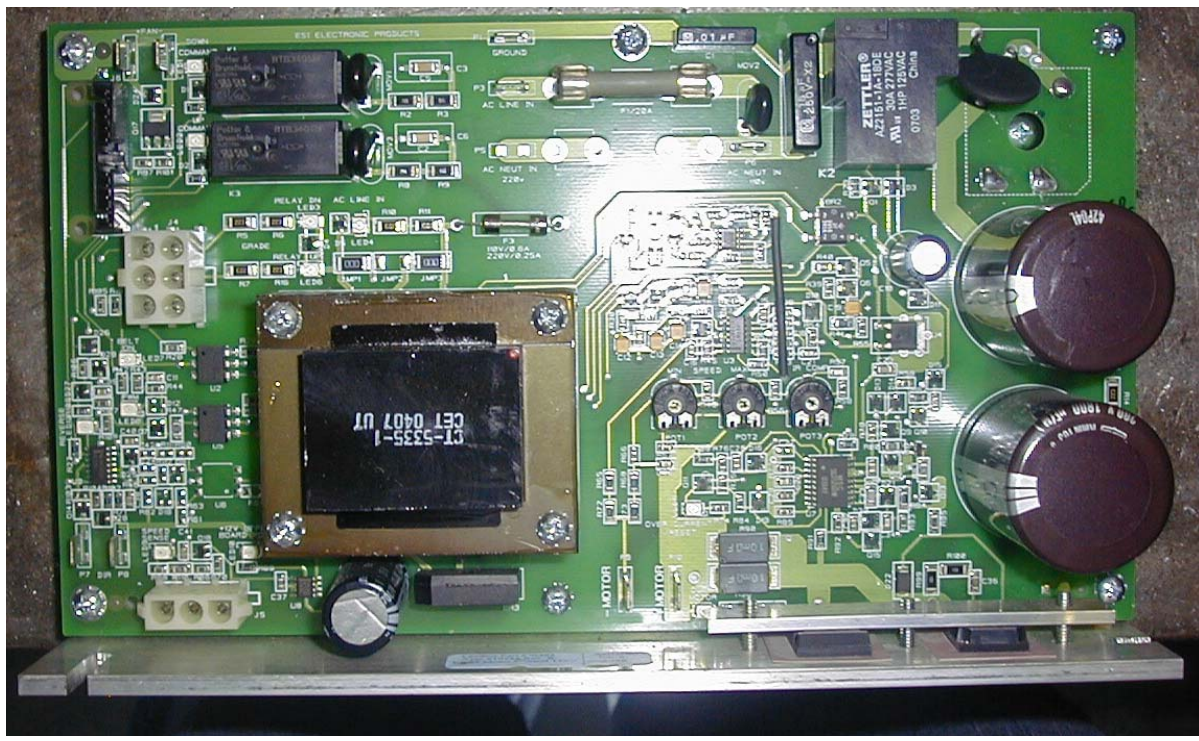
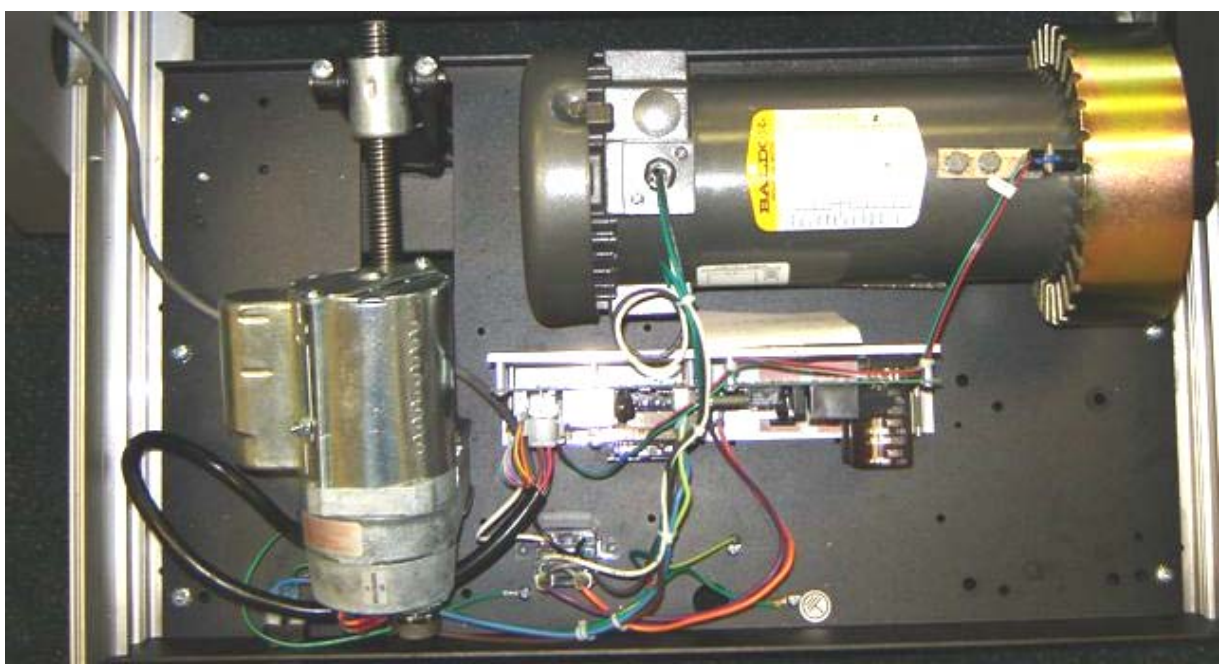

LOWER SCHEMATIC FOR REVERSING REHABILITATION TREADMILL (RTM-REV)

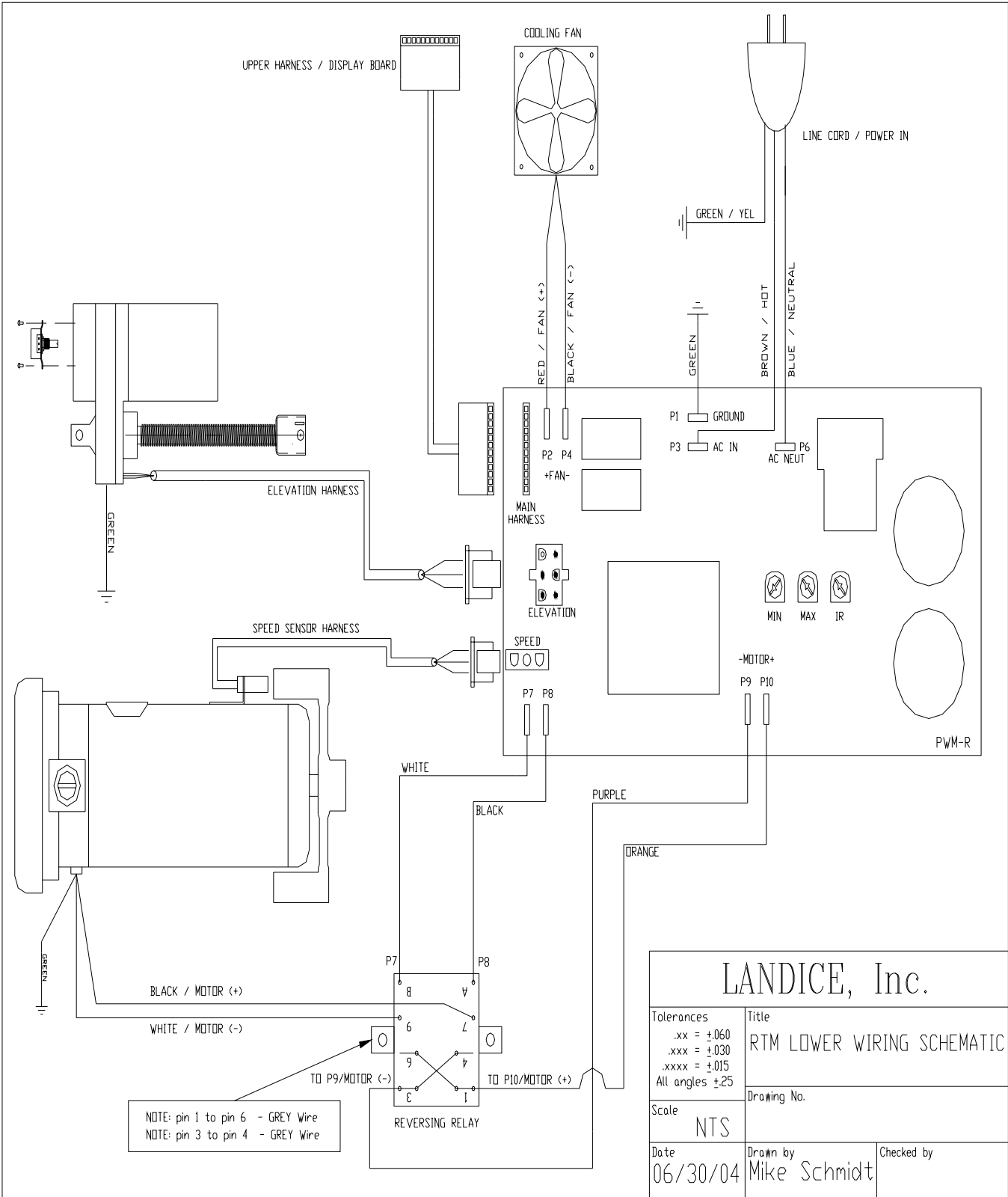

LANDICE, Inc.		
Tolerances .xx = ±.060 .xxx = ±.030 .xxxx = ±.015 All angles ±.25	Title RTM LOWER WIRING SCHEMATIC	
Scale NTS	Drawing No.	
Date 06/30/04	Drawn by Mike Schmidt	Checked by

LOWER SCHEMATIC WITH REVERSE RELAY

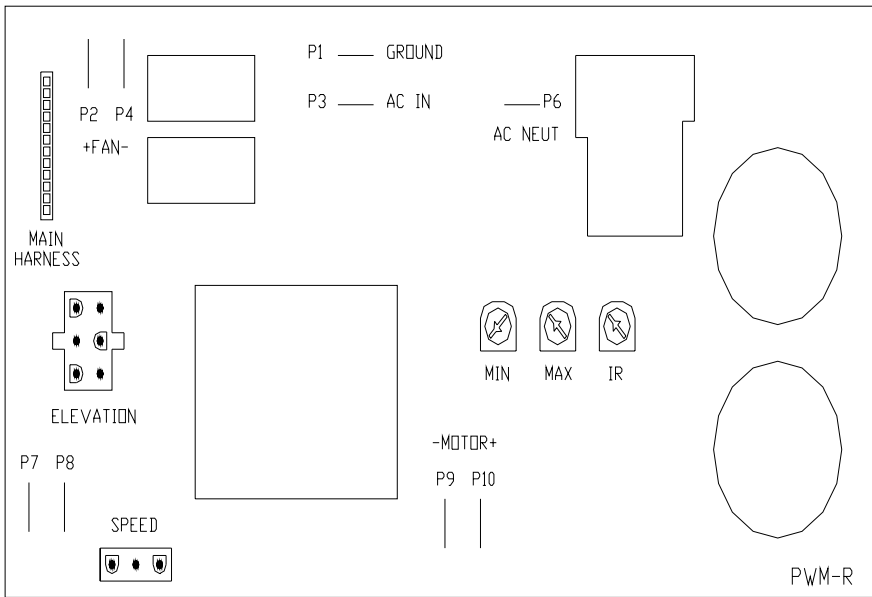

CONNECTION	WIRE COLOR
1 TO P10	ORANGE
1 TO 6	GREY
3 TO P9	PURPLE
3 TO 4	GREY
7 TO MOTOR BLK	BLACK
9 TO MOTOR WHT	WHITE
A TO P8	BLACK
B TO P7	WHITE
PAN GRND TO P1	GREEN
AC IN TO P3	BROWN
AC NEUT TO P6	BLUE
FAN (+) TO P2	RED
FAN (-) TO P4	BLACK

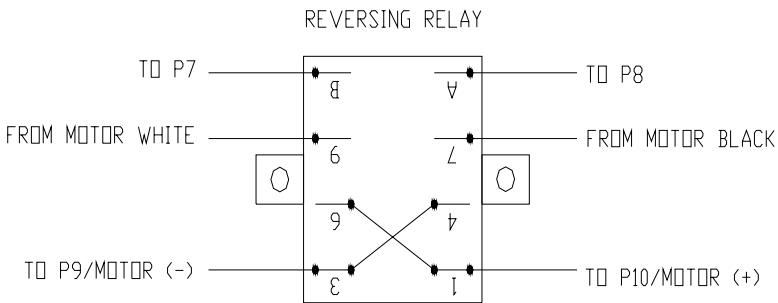

LANDICE, Inc.		
Tolerances .xx = ±.060 .xxx = ±.030 .xxxx = ±.015 All angles ±.25	Title <p style="text-align: center; font-size: 1.1em;">RTM Relay wiring</p>	
Scale <p style="text-align: center;">NTS</p>	Drawing No.	
Date	Drawn by <p style="text-align: center;">J. Erazo</p>	Checked by

LANDICE Reversing Rehabilitation Treadmill – RTM-REV



How it work!

The “REVERSE” button is located in the same place as the “PROGRAM SELECT” button on a normal PST. There is a little cut out for a red LED in the upper right hand corner of this button. Once the “REVERSE” button is pressed, the red LED will light up, indicating that it’s in the REVERSE mode. You will see a -.0 in the speed window. Next you will hear three clicks. The belt switch relay is opening (1st click), closing the reverse relay (2nd click) then the belt switch relay closes again (3rd click). You can now adjust the speed window to the speed you want.

Remote Start/Stop Switch

The switch plugs into the left hand side of the upper display board. When installing a RTM-REV, run the wire into a hole by the Contact Heart Rate harness. The wire is held in by a strain relief (same as the line cord). Then plug it into the upper board. When you press the remote start/stop switch the treadmill will pause like pulling out the safety lanyard. The only exception is that if you are set to a speed higher than 1mph and restart the machine, the treadmill will start up at 1mph. If you pause it and the speed is set lower than 1mph, the treadmill will restart at that speed.

Roller Guides for Treadbelt Tracking.

There are four roller guides to keep the treadbelt centered when it’s running in the reverse position. This helps the belt from tracking to one side. There are four roller guides located at the front & rear deck slats. They are positioned at the end of the deck slat and will spin when the belt starts to touch it. Refer to Diagram A for a picture of the roller guide.

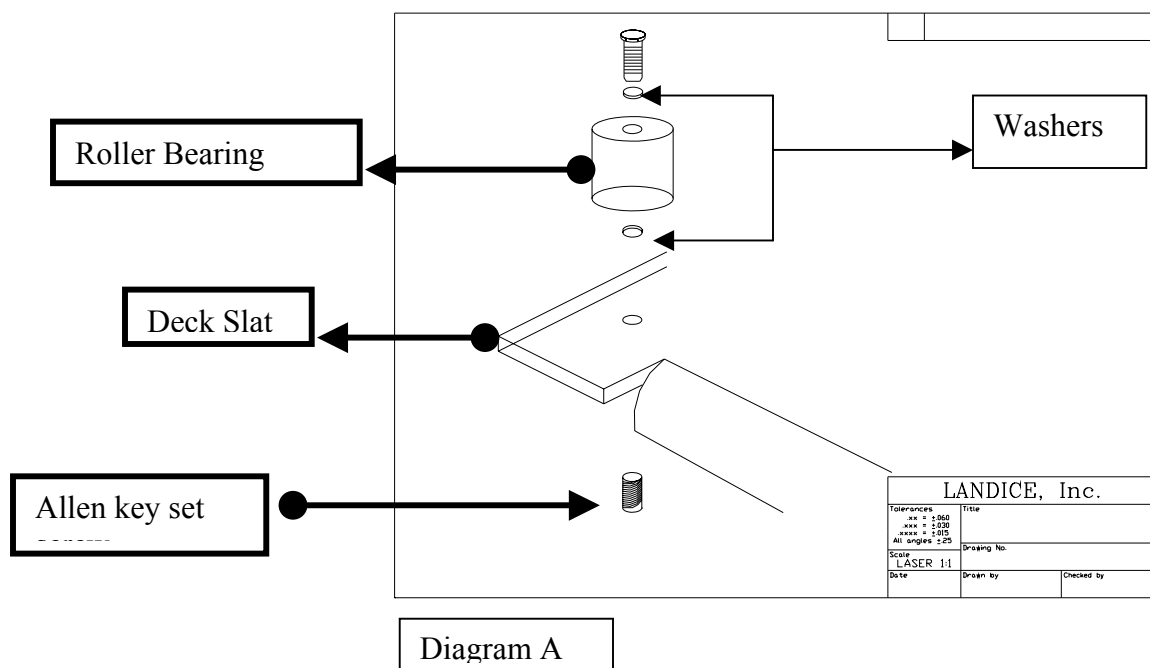

These roller guides are almost silent in forward position, but may be heard in the reverse position. The roller guides should spin freely. Loosen the set screw with a 10/32 allen key until the roller guide to spins freely.

---NOTE: Always track the treadmill in the forward position---

Contact Heart Rate.

This treadmill has a Contact Heart Rate option and is the same set up as the L9 Club's with Contact Heart Rate. Nothing has changed for this feature.

Medical Rails.

This will be the same set up as any other treadmill with medical rails.

Voltage Readings off the PWM-R.

VOLTAGE POINTS	AC VOLTAGE	DC VOLTAGE
P3(AC IN) & P6(AC NEUT)	110.4-120 VAC	N/A
P2(FAN +) & P4(FAN -)	N/A	12VDC
P7 & P8	N/A	15VDC
WIRE HARNESS (BLK&GREEN)	N/A	12-17VDC
P10(MOTOR+) & P9(MOTOR-)	N/A	1MPH = 10VDC

LED's for PWM-R

LED	COLOR	PURPOSE
AC LINE IN	GREEN	INDICATING VAC IS GOING INTO THE BOARD
+12 UPPER BOARD POWER	GREEN	INDICATING VDC IS GOING TO THE UPPER BOARD
BELT ON	GREEN	INDICATING THAT THE BELT SWITCH RELAY IS CLOSED
DOWN COMMAND	GREEN	INDICATING THAT THE UPPER BOARD CLOSED THE DOWN RELAY
UP COMMAND	GREEN	INDICATING THAT THE UPPER BOARD CLOSED THE UP RELAY
RELAY DN	ORANGE	INDICATING THAT 120VAC IS GOING TO THE ELEV. MOTOR
RELAY UP	ORANGE	INDICATING THAT 120VAC IS GOING TO THE ELEV. MOTOR
PWM	ORANGE	INDICATING THAT THE UPPER BOARD IS SENDING A SPEED SIGNAL TO PWM
RUN AWAY	ORANGE	INDICATING THAT THE BELT IS MOVING FASTER THAN IT SHOULD
OUT CURRENT / RESET	ORANGE	INDICATING THAT AN AMOUNT OF EXCESSIVE CURRENT IS GOING THROUGH THE BOARD
SPEED SENSE	ORANGE	INDICATING IF THERE IS SPEED SENSOR FEEDBACK
REVERSE	GREEN	INDICATING THAT THE REVERSE RELAY IS CLOSED

NOTE: USE THIS FOR THE DIAGNOISING THE RTM (-REV) TREADMILL

Upper display lights up but treadbelt doesn't move: L5 Error

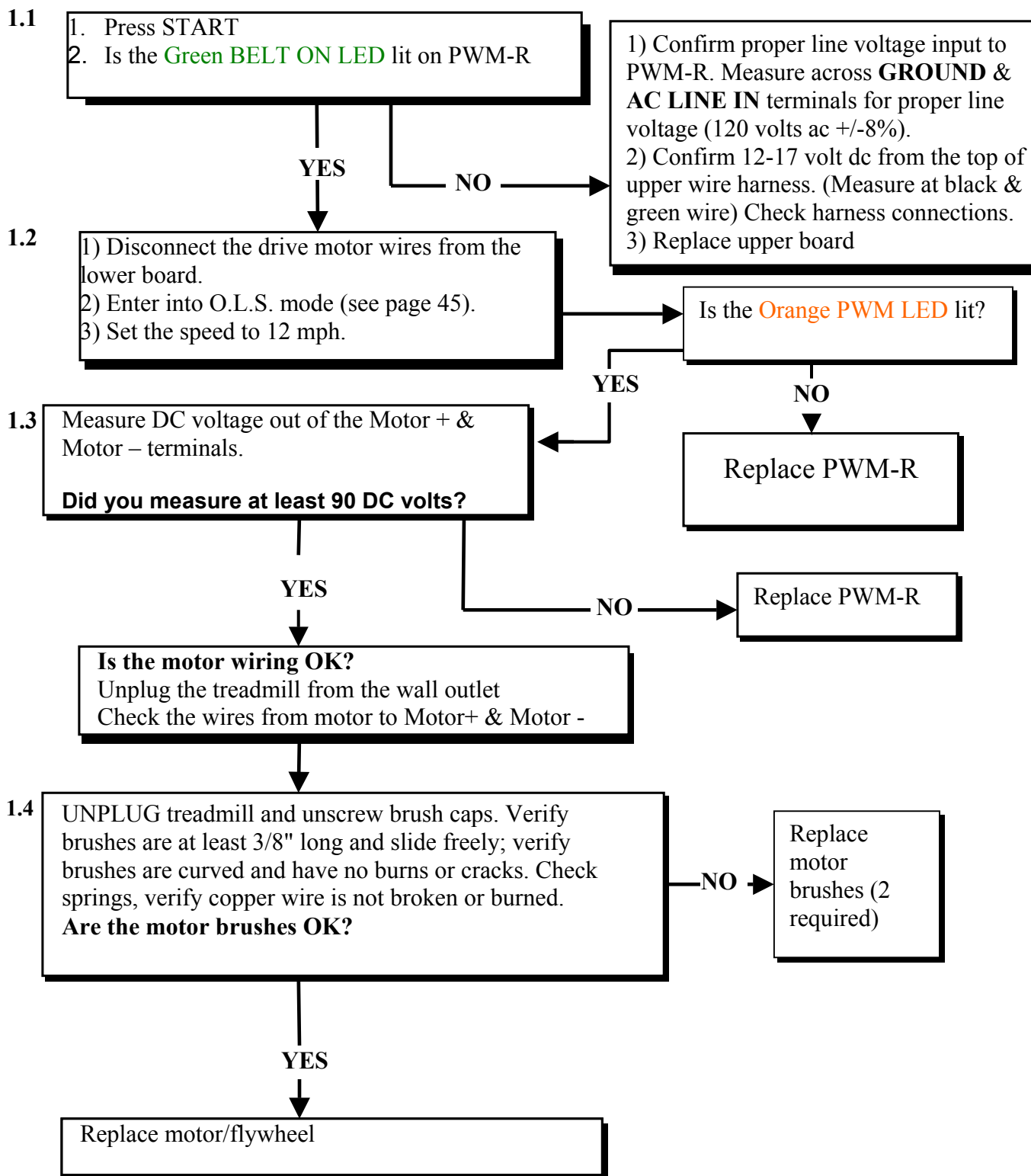

NOTE: USE THIS FOR DIAGNOSING THE RTM - REVERSE

Treadmill does not go in Reverse, No error code

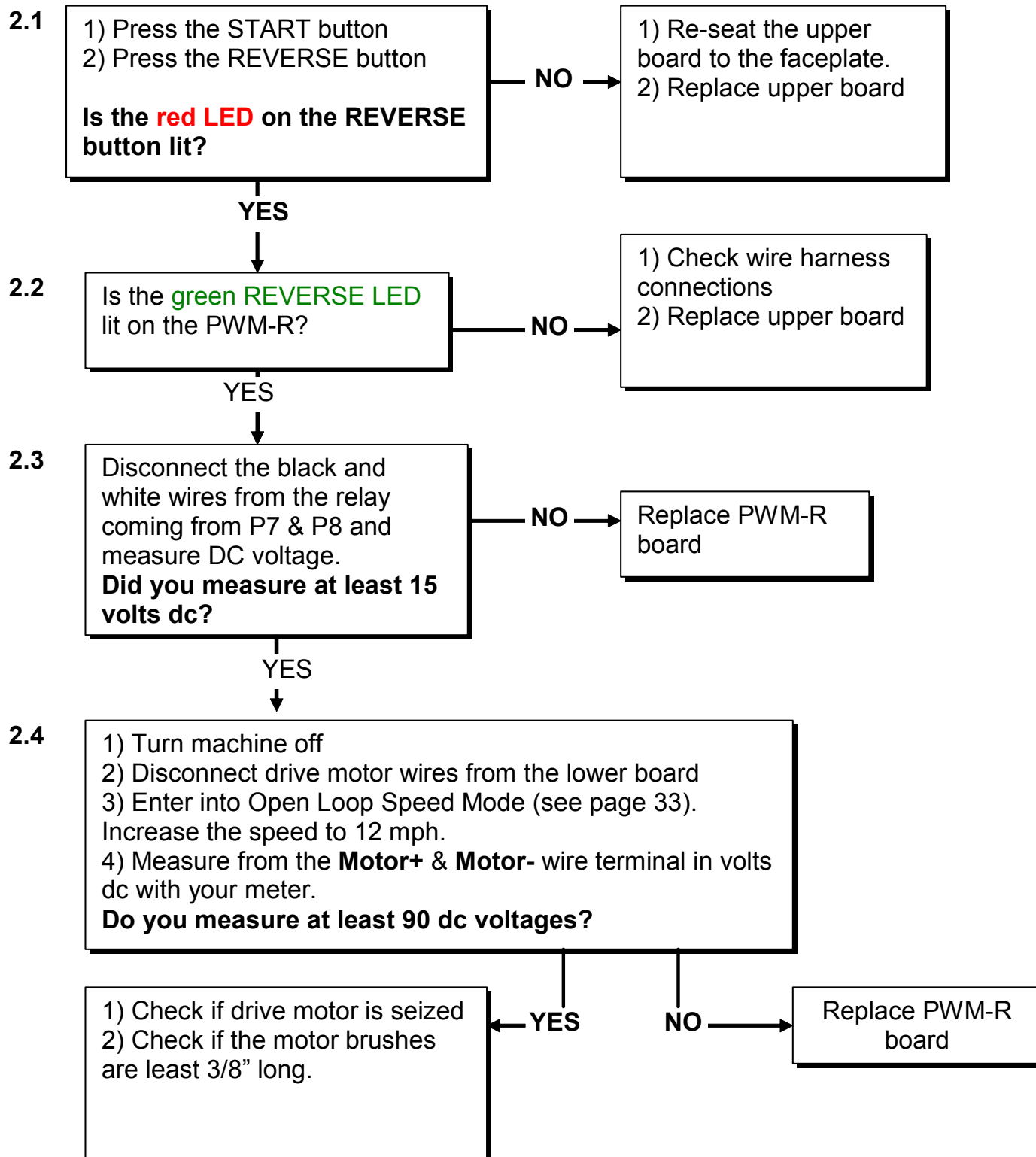

NOTE: USE THIS FOR DIAGNOSING THE PWM-R; RTM (-REV)

Elevation system not functioning or PO (Pot Out) error code displayed in the two digit speed window.

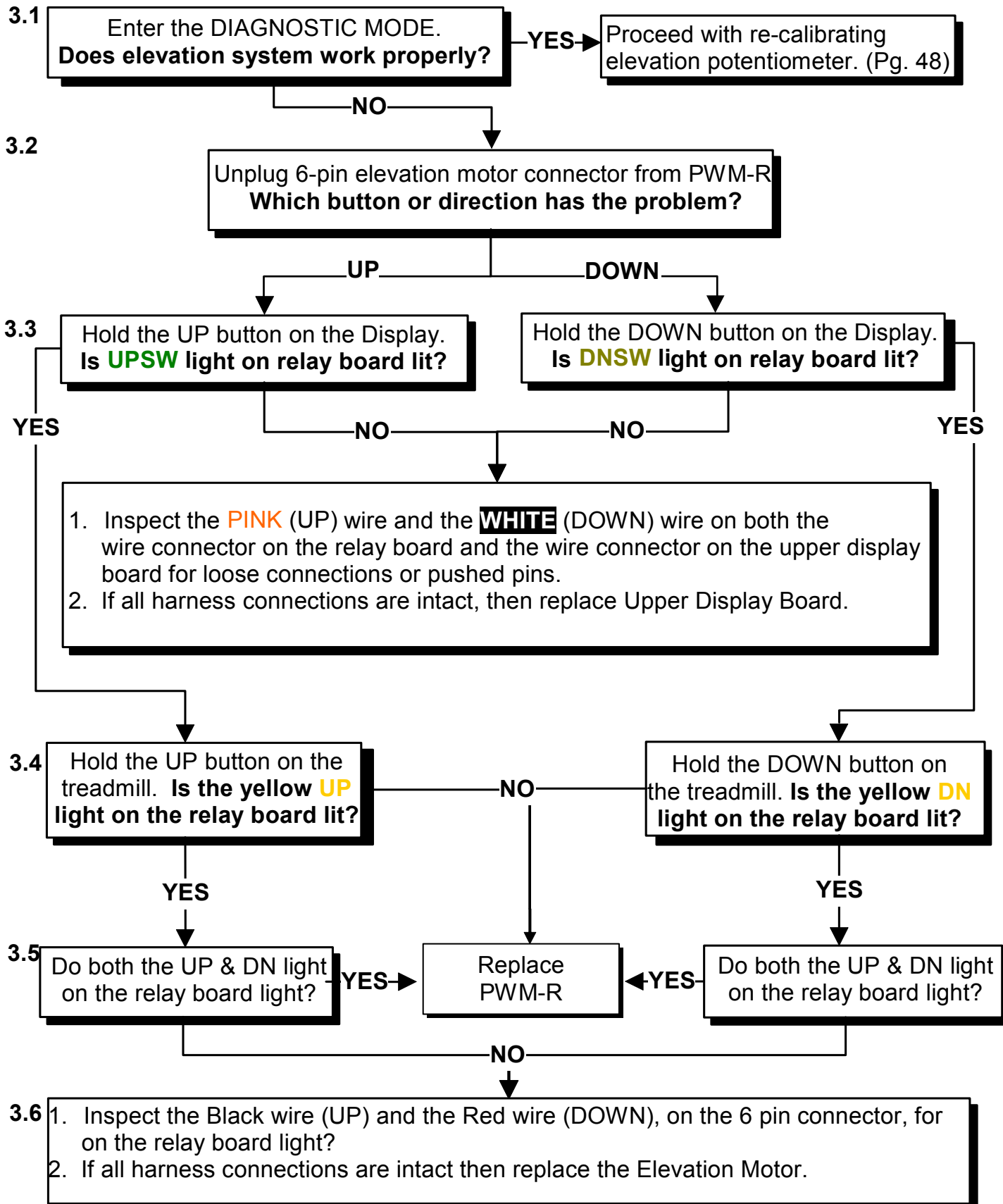

NOTE: USE THIS DIAGNOSING FOR RTM(-REV)

Upper display lights up; treadbelt moves; speed will not increase; L5 error.

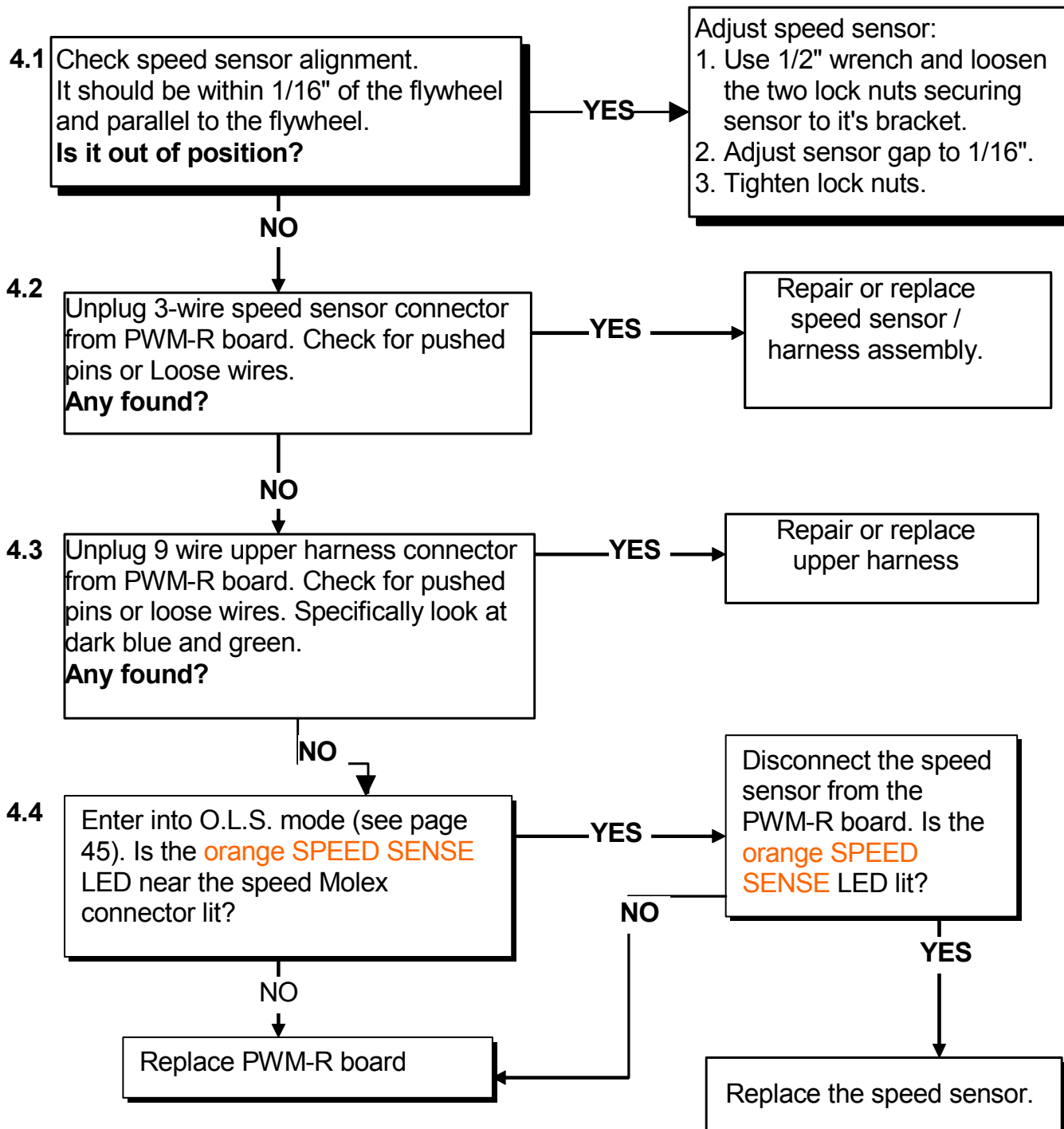

Landice Pot calibration for ESI 110-v PWM-R on Rehabilitation treadmill

MOTOR SPEED	
OPEN LOOP	
COMMANDED	SENSOR
0.1	0.2/0.3
0.5	0.5/0.6
1.0	1.0/1.1
5.0	4.3/4.4
10	8.5/8.6
11	9.2/9.3
12	10.1

POT SETTING



MIN POT
8 o'clock



MAX POT
10:45

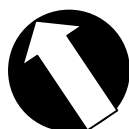

IR POT
11 o'clock

Enter into O.L.S. Mode is Fast and START simultaneously

Speeds and pot setting listed above are taken from the factory setting.

For best low-speed feel we set the MIN pot so that speed reads from 0.2 to 0.3 mph when commanded to 0.1 in open loop. This is usually done by calibrating the MIN pot around 8 o'clock. The MAX is set around 10:45 for the best high-speed feel. Then, the IR pot is a set to give smooth belt movement with a loaded. The IR pot calibration setting is generally around 11 o'clock.

Note: All settings are preset from the factory however by changing the necessary speed pot the speed of the machine will vary. For torque and surging adjust the IR pot. If the treadmill speed is not resolve from speed calibration then replace the PWM-R board.

DIAGNOSTIC FEATURES ON L60-SERIES TREADMILLS

NOTE: The following information is for diagnostic and troubleshooting purposes and is meant to be used by authorized Landice service technicians **ONLY** and should not be made available to the general public.

EXECUTIVE TRAINER

- 1- MENU/ START Accesses Diagnostic mode/Display Software version
Open loop Speed Mode/Total hours
 - 2 - DOWN/PAUSE/START Reboots
 - 3- METRIC/ENGLISH Enter into Menu mode then press SETUP, finally,
Press RETURN
 - 4 - Press the gray circle bottom Toggles between Metric/English
- NOTE:** The home ET's treadmill prior to version 1.04 does not change in grade percent
The home units with software version 1.04 and after

CARDIO TRAINER

- 1 - DISPLAY/START Accesses Diagnostic mode/Displays software version
Open Loop Speed Mode/Total hours
- 2 - DOWN/PAUSE/START Reboots.
- 3- MANUAL/START METRIC/ENGLISH
- 4 - UP/DOWN/START Toggles 12% and 15% elevation selection.

PRO SPORTS TRAINER/REHABILITATION TREADMILL/ REVERSING REHABILITATION TREADMILL

- 1 - DISPLAY/START Accesses Diagnostic mode
 - 2 - FAST/START Open Loop Speed Mode.
 - 3- DOWN/PAUSE/START Reboots
 - 4- DOWN/START METRIC/ENGLISH
- NOTE:**(For PST's with software version 2.0 and after)
- 5- UP/DOWN/START Toggles 12% and 15% elevation selection

L-SERIES TREADBELT SPEED FORMULAS

Formula: Treadbelt Speed L7 Series

$$\frac{1\text{mph}}{1\text{hr.}} \quad \times \quad \frac{1\text{rev.}}{114\text{in.}} \quad \times \quad \frac{1\text{hr.}}{60\text{min.}} \quad \times \quad \frac{12\text{in.}}{1\text{ft.}} \quad \times \quad \frac{5,280\text{ft}}{1\text{mile}} \quad = \mathbf{9.3\text{rpm}}$$

Formula: Treadbelt Speed L7-60 Series

$$\frac{1\text{mph}}{1\text{hr.}} \quad \times \quad \frac{1\text{rev.}}{122\text{in.}} \quad \times \quad \frac{1\text{hr.}}{60\text{min.}} \quad \times \quad \frac{12\text{in.}}{1\text{ft.}} \quad \times \quad \frac{5,280\text{ft}}{1\text{mile}} \quad = \mathbf{8.7 \text{ rpm}}$$

Formula: Treadbelt Speed L8 & L9 Series

$$\frac{1\text{mph}}{1\text{hr.}} \quad \times \quad \frac{1\text{rev.}}{137\text{in.}} \quad \times \quad \frac{1\text{hr.}}{60\text{min.}} \quad \times \quad \frac{12\text{in.}}{1\text{ft.}} \quad \times \quad \frac{5,280\text{ft}}{1\text{mile}} \quad = \mathbf{7.7\text{rpm}}$$

Formula: Treadbelt Speed L8622 & L9622 Series

$$\frac{1 \text{ mph}}{1\text{hr.}} \quad \times \quad \frac{1\text{rev}}{136\text{in}} \quad \times \quad \frac{1\text{hr}}{60\text{min}} \quad \times \quad \frac{12\text{in}}{1\text{ft}} \quad \times \quad \frac{5,280\text{ft}}{1 \text{ mile}} \quad = \mathbf{7.8 \text{ rpm}}$$

These formulas are useful for troubleshooting speed problems when the technician does not have a tachometer. You can simply count how many times the treadbelt revolves in one minute (rpm) and divide by the appropriate number listed above.

Example: L8 Club treadmill.

Step1: Place a piece of tape on treadbelt. This will make it easier to count your revolutions.

Step2: Turn treadmill on and increase speed to 6.0mph.

Step3: Start your stopwatch and begin to count treadbelt revolutions.

Step4: Take your rpm's and divide by 7.7.

Your treadbelt revolutions should be approximately 46.2 or 46; this is the equivalent of 6 mph.

NOTE: The most accurate form of calculating speed is to use a tachometer.

ELEVATION POTENTIOMETER CALIBRATION

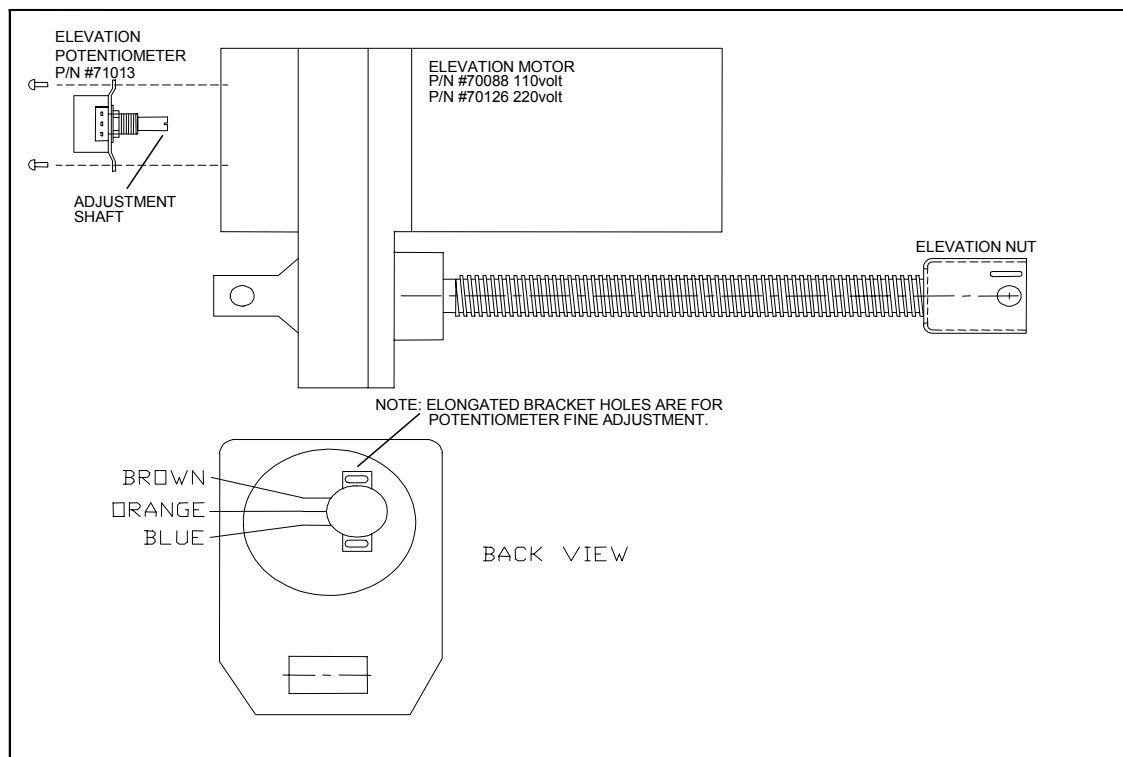

Enter Diagnostic Mode L60's series:

Press **OFF** to turn treadmill off.

L60-Series ET's – Hold MENU & START simultaneously

L60-Series CT's – Hold DISPLAY & START simultaneously

L60-Series PST's – Hold DISPLAY & START simultaneously

Calibrate the elevation potentiometer:

1. Visually confirm treadmill is level. (0% grade). Press down arrow for elevation till machine is level.
2. The potentiometer should read 0.0 or 0.1 (zero) for all models after 11/7/00. Prior to 11/7/00, the potentiometer should be set to -0.4 to -0.6.
NOTE: Elevation window shows actual elevation. Display shows potentiometer setting.
3. If the setting is incorrect, follow the steps below.
 - STEP 1:** Turn the post of the potentiometer all the way **CLOCKWISE**
 - STEP 2:** Slowly turn the potentiometer **COUNTER CLOCKWISE** until the setting is correct. (**NOTE:** If the setting seems stuck at 25.5 check that pot wires are seated in the correct order and that upper wire harness connection is seated tightly.)
4. Carefully install potentiometer into the motor housing.

***NOTE: The setting may vary when inserting the potentiometer into the motor. As long as the change is minimal, fine adjustment can be achieved after the potentiometer is secured into the motor housing.**

5. Press **OFF** to turn treadmill off.

Elevation Nut setting for L9 Treadmills

This setting has been revised to correct the treadmill from running off level. With the elevation nut flush with plastic on the shaft, turn the nut 8 full turns for the 110v elevation motors and 7 ½ turns with the 220v elevation motors.

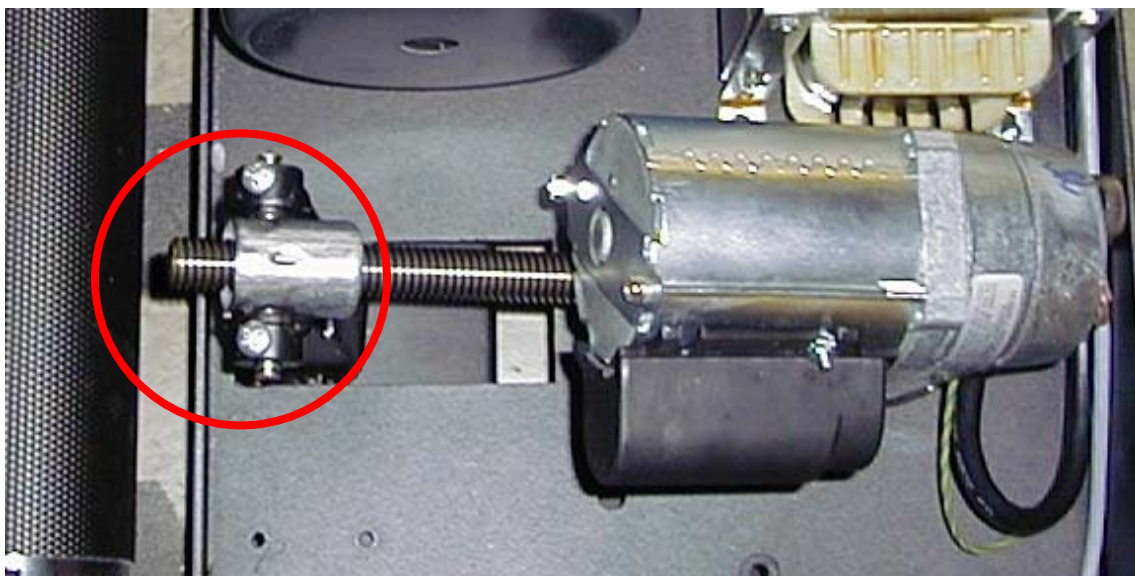

This picture shows a properly adjusted elevation nut.

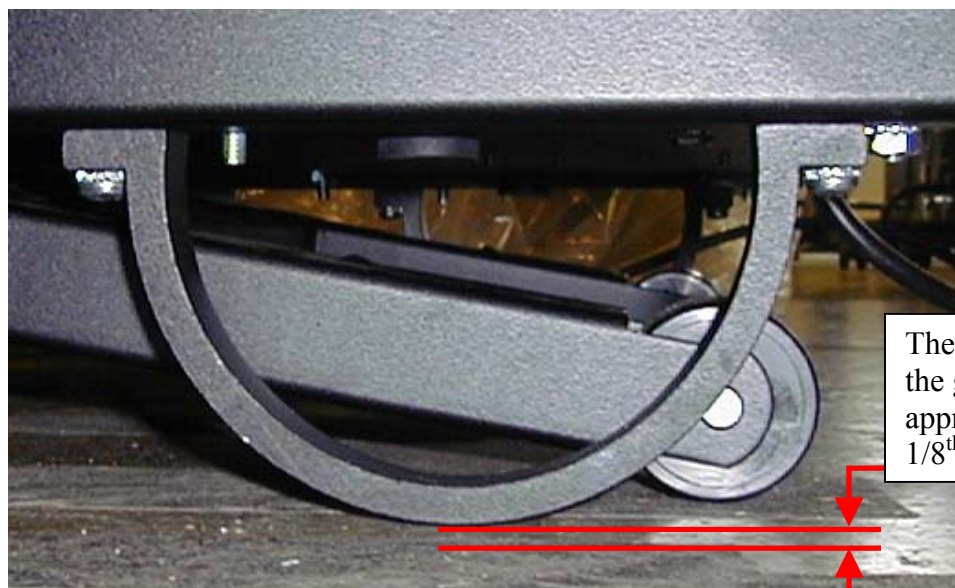

This picture shows the treadmill set to “0%” grade. Notice the actual half moon feet are NOT touching the ground. Meaning, the elevation legs are supporting the weight of the treadmill.

FOR TECHNICAL ASSISTANCE CALL 1-800-LANDICE

ACCESSING TOTAL MILES/HOURS ON L-SERIES TREADMILLS

*****NOTE:** The following applies to Landice's latest models, manufactured after October 1, 2003.

1. Executive Trainer

Total hours/miles on an Executive Trainer display can be accessed via Diagnostic Mode. To access diagnostic mode follow the steps outlined below:

- A. Make sure the treadmill is turned off.

- B. Hold down the  and  buttons simultaneously until the diagnostic screen comes up.

- C. Total Hours/Miles will appear at the bottom of the diagnostic screen:

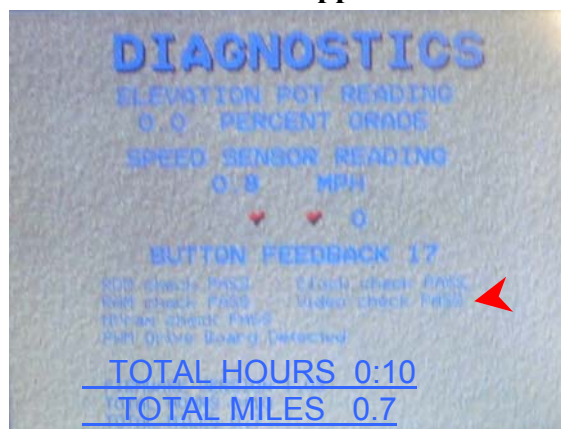

2. Cardio Trainer

Similar to the Executive Trainer, total hours/miles on a Cardio Trainer display can be accessed via Diagnostic Mode. To access diagnostic mode follow the steps outlined below:

- A. Make sure the treadmill is turned off.

- B. Hold down the  and  buttons simultaneously until the diagnostic screen comes up.

- C. Total Hours/Miles will appear at the bottom of the diagnostic screen:



3. Pro Sports Trainer & Rehabilitation Treadmill

Please note there is **NO** way to access total hours/miles on the Pro Sports Trainer and RTM

To change current production machines from English to Metric

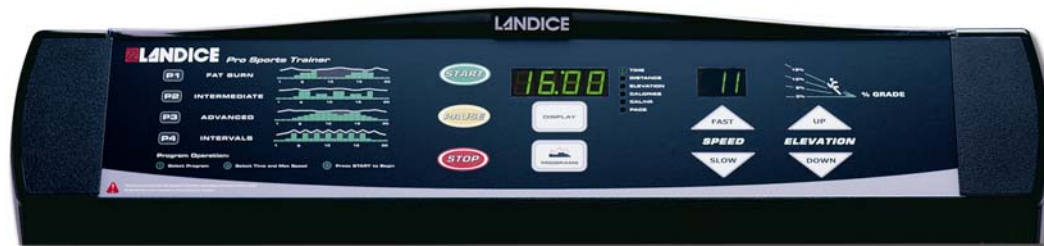

Pro Sport Trainer - Version 2.0

Approximately manufactured between 10/2003 – 11/2005

- 1) Turn the treadmill off by pressing STOP
- 2) Press DOWN and START simultaneously
- 3) Press STOP

Pro Sport Trainer – Version 2.01

Approximately manufactured after 11/2005

- 1) Turn the treadmill off by press STOP
- 2) While off press the DOWN, SLOW, and START button simultaneously
- 3) Press STOP



Cardio Trainer

Approximately manufactured between 10/2003-11/2005

- 1) Turn the treadmill off by pressing STOP
- 2) Press MANUAL and START simultaneously
- 3) Press STOP

Approximately manufactured after 11/2005

- 1) Turn the treadmill off by pressing STOP
- 2) Press MANUAL, CARDIO, and START simultaneously
- 3) Press STOP



Executive Trainer

- 1) Press START
- 2) Enter in the Menu mode and select SETUP
- 3) Select ENGLISH
- 4) Press RETURN



Rehabilitation Treadmill (Reverse)

- 1) Turn the Treadmill off by pressing STOP
- 2) Press Elevation DOWN and START simultaneously
- 3) Press STOP

Rehabilitation Treadmill – Version 2.01

Approximately manufactured after 3/2006

- 1) Turn the treadmill off by press STOP
- 2) While off press the DOWN, SLOW, and START button simultaneously
- 3) Press STOP

**BUTTON FEED BACK IN DIAGNOSTIC
MODE**

<i>CODE#</i>	<i>Executive Trainer</i>	<i>Cardio Trainer</i>	<i>Pro Sport Trainer</i>	<i>Rehabilitation RTM (Reverse)</i>
1	LEFT 1 (TOP)	1	START	START
2	LEFT 2	2	PAUSE	PAUSE
3	LEFT 3	3	DISPLAY	DISPLAY
4	LEFT 4 (BOTTOM)	4	FAST	Reverse (only on RTM-REV)
5	RIGHT 1 (TOP)	5	SLOW	FAST
6	RIGHT 2	6	UP	SLOW
7	RIGHT 3	7	DOWN	UP
8	RIGHT 4 (BOTTOM)	8		DOWN
9	PREV	9		
10	MENU	QUICK SPEED		
11	NEXT	0		
12	START	QUICK GRADE		
13	PAUSE	START		
14	FAST	PAUSE		
15	SLOW	DISPLAY		
16	UP	MANUAL		
17	DOWN	PROGRAM		
18	QUICK SPEED	CARDIO		
19	QUICK GRADE	FAST		
20	0	SLOW		
21	1	UP		
22	2	DOWN		
23	3			
24	4			
25	5			
26	6			
27	7			
28	8			
29	9			

Conducting a membrane bypass test can also test the functionality of a membrane panel.

Membrane Panel Bypass Test

When a treadmill with a membrane experiences a loss in power to the upper display, such as when a customer presses the START button and nothing happens, a possible cause of this is a bad membrane panel. A membrane panel bypass test can verify this. A membrane panel bypass test is conducted by literally taking the membrane and bypassing its functions. The membrane panel has small micro switches laminated inside that transmit the user's commands into treadmill functions. These functions can be simulated by means of a membrane bypass:

1. Disconnect the silver foil ribbon cable from the membrane panel.
2. Remove the membrane panel completely from the upper display board.
3. Use a **DRY** towel or a terry cloth to wrap over the open area of the control panel frame. Place the upper display board with wire harness still attached on top of the towel to prevent it from touching any metal.
4. Look at the pins where the silver membrane ribbon cable connected to the display board. You should note that printed on the green circuit board behind each pin is it's specific function.
5. Using a jumper (i.e. a jumper wire with two copper ends, a paper clip, or a voltmeter set to continuity) bypass the start button by touching one end of the jumper to the pin labeled **GND** or **GROUND**, and the other end of the jumper to the pin labeled **START** or **ON**. (Note on page 2 where to locate these pins on various Landice display boards) If the membrane is bad the treadmill will turn on and read "SAFE."
6. If it is necessary, replace the damaged membrane panel.

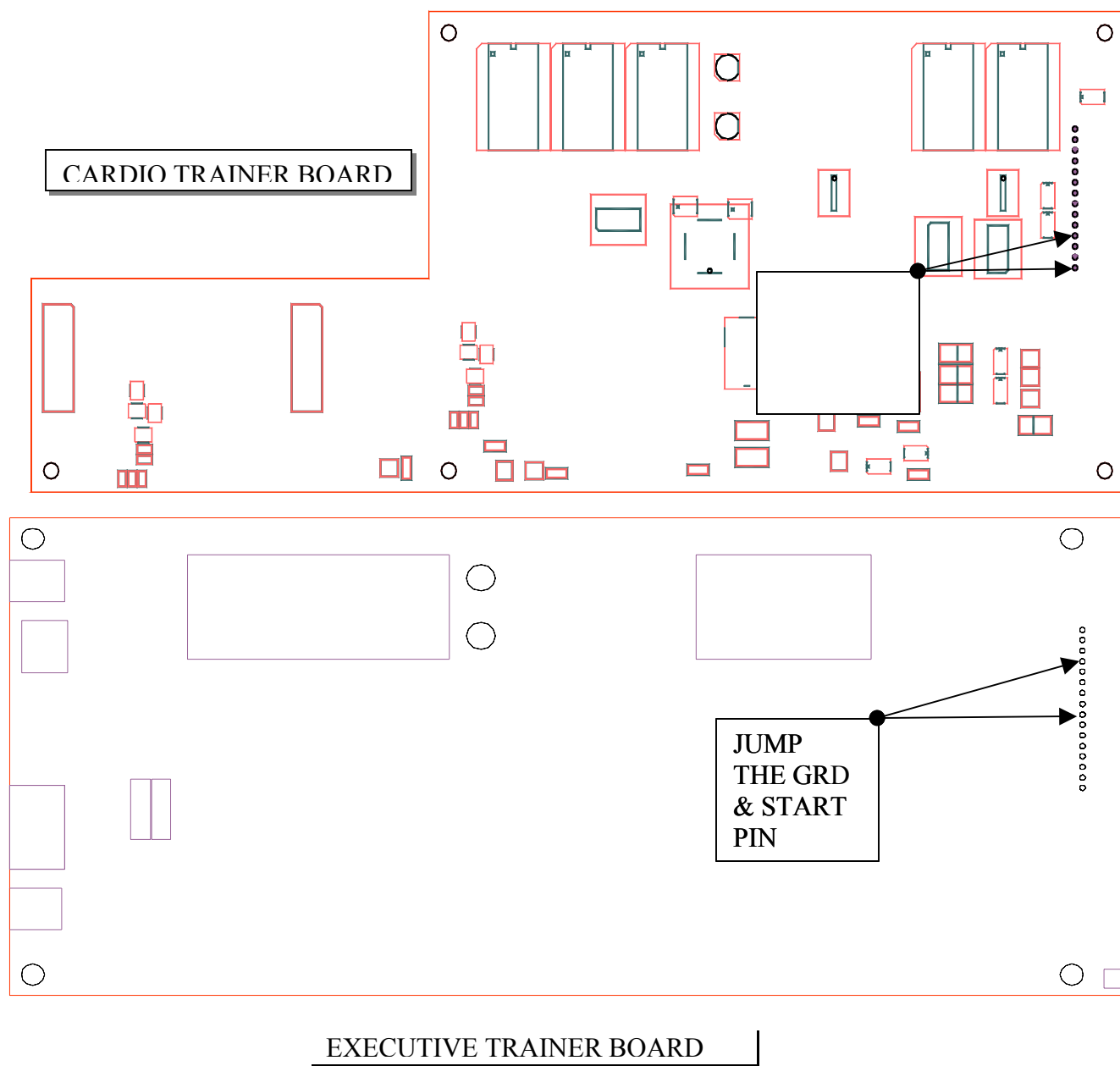

L8 & L9-22" WIDE TREADBELT & DECK REPLACEMENT

Tools required:

- *Power Screw Gun with #2 Phillips Head Bit
- *This is the only way to remove and install deck frame cover screws.
- 7/16 deep socket, 1/2 & 9/16 standard sockets with 3/8 ratchet
- 2" extension for 3/8 ratchet (use for removal of upright)
- Rubber Mallet, Lubriplate grease, Locking Pliers optional

Time required:

1 technician = 1 hour

Disassembly:

1. Turn treadmill ON and elevate to 15% grade.
2. **UNPLUG TREADMILL!**
3. Remove motor cover.
4. Remove upright assembly.
 - a. Remove control panel end caps.
 - b. Remove upright frame covers (pull outward from bottom).
 - c. Disconnect main upper wire harness from lower board.
 - *d. Loosen 8 total (4 each side) upright bolts; 7/16" socket with 2" extension.
 - * There is no need to completely remove these bolts from the frame.
 - e. Lift upright assembly UP and OFF.



Here is a picture of the treadmill frame with the upright assembly removed.

5. Remove right and left side frame covers.

- a. Remove 4 Phillips head screws per cover using power screw gun and #2 Phillips bit.
 - b. Remove 2 #8 machine screws located on the bed end caps.
 - c. Use rubber mallet to pop the frame cover out of the frame rail channel.
- Note: Make sure to strike the frame cover from the under side.

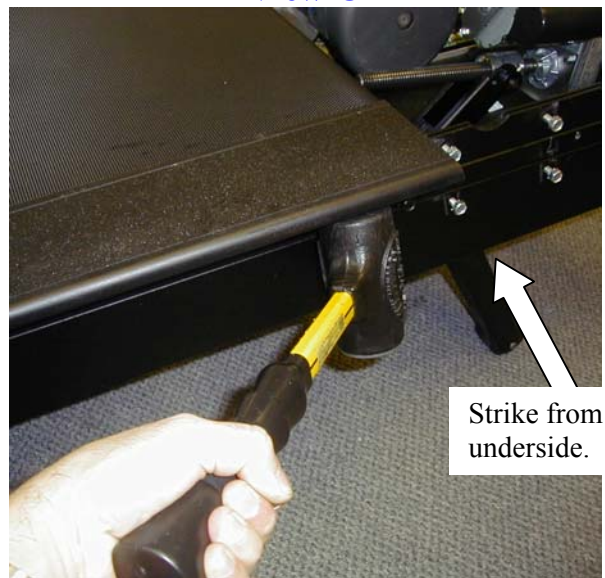
View-A**View-B****View-C**

6. Remove motor tensioning hook (7/16 deep socket); pivot motor back and remove belt.



7. Slide drive-belt off drive motor flywheel.

8. Remove rear-take up roller; (9/16" hex head bolts located rear of treadmill).



9. Remove front drive-roller; (1/2" hex head bolts on right and left side).



7. Lift deck out of treadmill frame assembly.

SERVICE TIP: When removing the deck by yourself, it's easier to lift one side first. Place the handle of your rubber mallet between the deck and frame. This

will keep the deck free from the deck posts. Then you can walk to the opposite side and lift the deck off.



8. Remove treadbelt.



Here's a picture of the fully disassembled treadmill.

Deck reversal:

Landice decks are reversible. They should be reversed **ONLY** when a new treadbelt is installed. You will need to remove the belt guides from the “old” side and install them on the “new” side. The deck is pre-drilled on both sides to accommodate the belt guides. If the deck has already been reversed then install a new deck with the new treadbelt.

Inspection:

Inspect the VFX absorbers and hardware for condition. Remove the absorbers from the mounting posts. Check for abnormal distortion, cracks or splits. Replace absorber if any defect is noted. Check that deck posts are tight (use lock pliers to tighten deck post). Apply a liberal amount of Lubriplate grease to the deck post. Install absorbers.

Reassembly:

1. Lay new treadbelt into the frame assembly.
2. Slide deck between the new treadbelt and into the frame assembly.
3. Install front drive roller. Make sure the drive roller shaft notches are resting on frame.
Note: Just start the drive roller bolts; **DO NOT TIGHTEN AT THIS POINT.**
Note: Make sure the drive belt is properly located.
4. Slide the drive belt around the drive motor flywheel.
Note: Install motor tensioning nylon washer and nut but do not tighten at this point.
5. Install the rear take up roller. Make sure rear roller shaft notches are resting on frame.
Note: Just start the take up bolts; **DO NOT TIGHTEN AT THIS POINT.**
6. Install frame covers.
Note: Place frame covers in there respected locations; Use rubber mallet to snap frame covers back down into side frame channels. Examine screw holes for proper alignment.
7. Tension the treadbelt just enough to seat the front drive roller. Meaning: The front drive roller has elongated mounting holes. The drive roller must be seated against the aft portion of this elongated hole. You can assure the proper seating by tightening the treadbelt tension. This will pull the drive roller aft and position it for tightening.



8. Tighten front drive roller bolts (1/2" socket).
9. Tension drive belt (7/16" socket / make sure belt can twist to 45 degrees).
10. Install upright assembly.
Note: Be careful of the upper harness. Do not pinch the harness between the frame and upright.
11. Plug upper harness back into the lower board. Secure harness to motor pan holding clip.
12. Plug treadmill in. Turn on and decrease elevation back to 1% grade. Check for proper belt tensions and treadbelt tracking.
13. Raise treadmill back to 15% grade, shut off and unplug.
14. Fit and secure the motor cover.
Note: You fit the motor cover before tightening the upright assembly to the frame. This makes locating the motor cover mounting holes much easier.
15. Tighten upright to frame (7/16" socket). **DO NOT OVERTIGHTEN!**
16. Install upright covers. Align at top and snap into place using palm of your hand.
17. Install control panel end caps.

TENSIONING

TREADBELT:

The same hex head bolts used for tracking, TENSION the treadbelt. To tighten the treadbelt; turn both screws clockwise the same amount. Failure to turn them equally will affect belt tracking. Need for tension is indicated by uneven belt speed and may be sensed by sudden stopping of the treadbelt when your foot comes down on the belt. Before tightening the treadbelt, assure that the treadbelt is loose and not the drive belt (see drive belt tensioning below). **DO NOT OVER TIGHTEN THE TREADBELT.**

DRIVE BELT:

The drive belt tensioning screw is located on the drive motor bracket.

By turning the nut clockwise you will pull down the motor bracket, tightening the drive belt. **DO NOT OVER TIGHTEN!** If you over tighten this belt you risk damaging the drive motor shaft. To gauge proper tension, twist the drive belt between motor and drive roller pulley.

The ideal tension, loosen until the drive belt slips and tighten until it stops, will allow you to twist drive belt 45 degrees.

If you cannot twist the belt at least 45° the belt is too tight.

**FOR TECHNICAL ASSISTANCE CALL
1-800-LANDICE**

PRO-RATE SCALE FOR WEAR ITEMS

The pro-rate scale applies to all wear items on commercial treadmills. Pro-rated items include the drive belt, motor brushes, deck, and walking belt.

LTD sold after August 1, 2002 carry a 5-year parts warranty. **Club** machines sold after January 1, 2003 are pro-rated under the 5 year scale. Wear items will get covered under full warranty for the first 6 months of ownership due to wear. Parts will not get covered due to freight damage.

Wear items are pro-rated as follows:

Up to 6 months	No Charge
6-12 months	80%
Year 2	60%
Year 3	50%
Year 4	40%
Year 5	30%

SERVICE REIMBURSEMENT POLICY:

This is offered to all Landice dealers as well as all authorized Landice service providers. Landice covers our treadmills with a 1-year labor reimbursement policy. That means we will pay to fix our treadmill as long as it's within one year from the date the treadmill was purchased.

Our Policy:

Landice will reimburse the selling dealer according to our flat rate labor schedule. If you are a service provider for Landice and do not sell our product, you have the option of billing us direct or you can bill the dealer that you're providing service for. Generally, if our capped rate does not cover your labor charge you would bill the selling dealer. The current rate is \$30.00 per hour and is capped at a maximum of one hour labor and one hour travel per treadmill failure. Diagnostic and return trips are not covered. Note that treadbelt tracking, treadbelt / drive belt tensioning, blown fuses, and set-up procedures are not covered by this warranty.

Set-Up Includes: Assembly, adjusting treadbelt and drive belt (if needed), walking the treadbelt and deck wax in, and performing any additional adjustments that may have been upset during shipping.

The dealer must call for a service authorization number **prior** to performing any service to verify the treadmill is under labor warranty. It is advisable to call Landice from the treadmill location to successfully diagnose the problem. This will insure that the correct part will be shipped out the first time. Labor claim forms must be submitted within three months from the date service was performed. Labor claim forms must be completely filled out and have the Landice Service Authorization number at the top.

The Service Warranty covers installation of parts shown to be defective in material or workmanship. The selling dealer is responsible for labor for treadmills needing repairs. A Service Authorization (SA) number must accompany any service reimbursement request. Service Authorization numbers are given when the selling dealer or the service technician calls Landice **prior** to beginning work on the treadmill. This allows Landice to verify that the treadmill is within the labor warranty and also aids us in helping the technician troubleshoot the treadmill. Landice welcomes technicians to call us from the field and gives these calls the highest priority.

This Service Warranty does **not** cover customer instruction, installation, setup, maintenance, or adjustments to treadbelt or drive belt.



SERVICE CLAIM FORM SA#

DEALER INFORMATION:		
Service Dealer / Dealer Name:		
Address		
City	State	Zip
Phone()		
Contact		

CUSTOMER INFORMATION		
Name		
Address		
City	State	Zip
Phone()	Contact	

TREADMILL INFORMATION		
Model	Date of Service	
Serial #	Date of Purchase	
Out of box problem	Yes	No

CUSTOMER COMPLAINT		

SERVICE PERFORMED		
TRAVEL / LABOR: Travel Time:	Labor Time:	TOTAL TIME: _____

VALIDATION SIGNATURES		
Service Rep. Signature	Customer Signature	Date

IN ORDER TO PROCESS THIS CLAIM IN THE LEAST AMOUNT OF TIME,
FAX/SEND THE SERVICE CLAIM WITH THE DEFECTIVE WARRANTY PART WITHIN 3 MONTHS OF THE DATE THE SERVICE WAS PERFORMED.
 DO NOT SUBMIT SERVICE CLAIMS WITHOUT SERVICE AUTHORIZATION NUMBERS.

Maintenance Checklist

- Check treadbelt tension and tracking
- Wipe underneath treadbelt
- Check drive belt tension
- Check motor brushes
- Use cleaning stone to dress comutator
- Vacuum under motor hood
- Vacuum around and under treadmill
- Lubricate deck with slipcoat if needed
- Wipe down display with soft cotton & **mild** soap and water.

Accessing total miles for CT's & ET's only	50
Anta/PWM combo	22
flowchart	29
schematic	23
speed calibration	34
(see speed formulas, pg. 47)	
Cardio Trainer LCD	
assembly membrane instruction	16
schematic	17
Diagnostic Mode & features	46
Elevation Potentiometer calibration	48
Elevation leg assembly for L9	49
Error codes	
CE	27
LS	24
OS	28
PO	25
SAFE	26
English to Metric mode, change	51
Executive membrane, color	
assembly instruction	19
schematic	20

INDEX PAGE

Exploded View	
Bed, L7	5
Bed, L8 & L9	6
Handrail	4
Motor pan	7
Upright	3
Membrane bypass test	53
Overspeed	33
Parts list	8
Pro-rate scale	62
Reading Rack Caddy assembly	15
RTM(-REVERSE)	
faceplate	38
flowchart	41
lower board PWM-R schematic	36
relay schematic	37
rollers guides	39
speed calibration	45
Service Authorization	
claim form	64
policy	63

INDEX PAGE

Safety key installation instruction	14
Software reboots instruction	46
Treadbelt speed formula	47
L8622 & L9622 walking belt replacement	55