

LANDICE

L10 Treadmill 90 Series Installation Manual



Part Number: 73208-6

Contents

- 1. Important Safety Instructions 3**
 - 1.1. Safety 3
 - 1.2. Grounding Instructions..... 5
 - 1.3. 120-Volt Treadmills..... 6
 - 1.4. 200 – 240-Volt Treadmills..... 6



- 2. Installation 9**
 - 2.1. Tools Needed 9
 - 2.2. Hardware Included..... 9
 - 2.3. Unpacking..... 10
 - 2.4. Assembly 14
 - 2.5. Cover Installation 23
 - 2.6. Leveling Treadmill..... 25
 - 2.7. Treadbelt Tensioning 27
 - 2.8. Treadbelt Tracking..... 28

1. Important Safety Instructions

1.1. Safety

Read all instructions before using the treadmill.
Save these instructions.

Veillez lire toutes les instructions avant d'utiliser le tapis roulant.
VEUILLEZ CONSERVER CES INSTRUCTIONS.

	<p>To reduce the risk of electric shock: always unplug the treadmill from the electrical outlet immediately after using and before cleaning.</p> <p>To reduce the risk of burns, fire, electric shock or injury to persons, keep the power cord away from heated surfaces. Be sure the cord has plenty of slack and cannot be pinched under the treadmill when it elevates and de-elevates.</p>
	<p>Treadmills require more power than other appliances and must be plugged into a dedicated power outlet. Failure to follow these guidelines may void product warranty.</p> <ul style="list-style-type: none">• Always plug treadmill directly into wall outlet receptacle.• Never use an extension cord, power strip, GFI or ARC Fault Breaker outlet. Contact a qualified electrician to add or move a power outlet if power cord does not reach desired location.• Check treadmill power cord connections (into treadmill and wall outlet) frequently as a loose connection may cause intermittent power loss or cause power cord to overheat.• Inspect power cord for wear or damage frequently; do not operate treadmill with a damaged cord.• Route power cord away from operating area; do not run power cord under treadmill, carpeting or furniture.• Position power cord away from high traffic areas to avoid a tripping hazard.

DANGER





Pour réduire le risque d'électrocution : toujours débrancher le tapis roulant de la prise électrique immédiatement après son utilisation et avant de le nettoyer.

Pour réduire le risque de brûlure, d'incendie, d'électrocution ou de blessure corporelle, tenez le câble électrique éloigné des surfaces chauffées. Assurez-vous que le câble ait suffisamment de mou et ne puisse pas se coincer sous le tapis roulant lorsqu'il s'élève ou s'abaisse.

ATTENTION

Les tapis de course nécessitent plus d'énergie que les autres appareils et doivent être branchés sur une prise de courant dédiée. Le non-respect de ces directives peut annuler la garantie du produit.

- Branchez toujours le tapis roulant directement dans la prise murale.
- N'utilisez jamais de rallonge, de multiprise, de prise GFI ou de disjoncteur ARC. Contactez un électricien qualifié pour ajouter ou déplacer une prise de courant si le câble électrique n'atteint pas l'emplacement souhaité.
- Vérifiez fréquemment les connexions du câble électrique du tapis de course (dans le tapis de course et la prise murale) car une connexion desserrée peut entraîner une perte de courant intermittente ou une surchauffe du câble électrique.
- Inspectez fréquemment le câble électrique pour détecter toute usure ou dommage; n'utilisez pas le tapis de course avec un cordon endommagé.
- Éloignez le câble électrique de la zone d'opération; ne pas faire passer le câble électrique sous le tapis roulant, la moquette ou les meubles.
- Éloignez le câble électrique des zones à fort trafic pour éviter tout risque de trébuchement.

	<p>Failure to leave ample clearance around the treadmill could cause you to be trapped between the treadmill and a wall if you fall, resulting in burns or other serious injury from the moving treadbelt. Allow a minimum clearance of 18 inches (46 cm) on each side of the treadmill. Allow a minimum clearance of 6 feet (183 cm) at the rear of the treadmill.</p>
	<p>Connect treadmill to a properly grounded, dedicated electrical outlet only. See the following Grounding Instructions.</p>
	<p>Le fait de ne pas laisser suffisamment d'espace dégagé autour du tapis roulant peut avoir comme conséquence, en cas de chute, que vous soyez immobilisé entre le tapis roulant et un mur, la courroie en mouvement pouvant causer des brûlures ou autres blessures. Laissez un espace dégagé d'au minimum 46 cm de chaque côté du tapis roulant. Laissez un espace dégagé d'au minimum 183 cm à l'arrière du tapis roulant.</p>
	<p>Ne branchez le tapis roulant que sur une prise électrique raccordée à la terre et exclusivement dédiée au tapis roulant. Voir les instructions de mise à la terre qui suivent.</p>

1.2. Grounding Instructions

This product must be grounded. If it should malfunction or break down, grounding provides a path of least resistance for electric current to reduce the risk of electric shock. The treadmill is equipped with a cord having an equipment grounding conductor and a grounding plug. The plug must be plugged into an appropriate outlet that is properly installed and grounded in accordance with all local codes and ordinances.



Improper connection of the grounding connector can result in a risk of electric shock. Check with a qualified electrician/service technician if you are in doubt as to whether the treadmill is properly grounded. Do not modify the plug provided with the treadmill—if it will not fit the outlet, have a proper outlet installed by a qualified electrician.

1.3. 120-Volt Treadmills

Treadmills marked 120 VAC are intended for use with a grounding plug in a nominal 120-volt circuit. Ensure the treadmill power cord is connected to an outlet having the same configuration as the plug. No adapter should be used with 120 VAC treadmills.

1.4. 200 – 240-Volt Treadmills

Treadmills marked 200 – 240V AC are intended for use on a circuit having a nominal rating greater than 220V and are factory-equipped with a specific power cord and plug to permit connection to a proper electrical circuit. Ensure the treadmill power cord is connected to an outlet having the same configuration as the plug. No adapter should be used with 200 – 240 VAC treadmills.

If the treadmill must be configured for use on a different type of electrical circuit, qualified service personnel should make the proper connection.

Ce produit doit être mis à la terre. En cas de dysfonctionnement ou de panne, la mise à la terre offre une voie de moindre résistance au courant électrique, ce qui réduit de risque d'électrocution. Le tapis roulant est équipé d'un câble électrique muni d'un fil conducteur de mise à la terre et d'une fiche de mise à la terre. Cette fiche doit être branchée sur une prise adaptée, correctement installée et raccordée à la terre conformément à tous les codes et règlements locaux.



Un mauvais raccordement à l'équipement de mise à la terre vous expose à un risque d'électrocution. Renseignez-vous auprès d'un électricien/technicien de service qualifié en cas de doute sur la mise à la terre correcte du tapis roulant. Ne modifiez pas la fiche fournie avec le tapis roulant: si elle ne convient pas à la prise, faites installer une prise adaptée par un électricien qualifié.

Tapis de course 120 VCA

Les tapis roulants marqués 120 VCA sont conçus pour être utilisés avec une prise de terre dans un circuit nominal de 120 volts. Assurez-vous que le cordon d'alimentation du tapis de course est branché sur une prise ayant la même configuration que la prise. Aucun adaptateur ne doit être utilisé avec les tapis roulants 120 VAC.

Tapis roulant 200 – 240 volts

Les tapis roulant sur lesquels est inscrit 200-240 CA (VAC) sont destinés à une utilisation à une tension nominale supérieure à 220 V et équipés en série d'un câble électrique et d'une fiche spécifiques pour permettre le branchement sur une prise adaptée. Si le tapis roulant doit être configuré pour une utilisation sur un type de circuit électrique différent, il convient de faire appel à du personnel de service qualifié pour installer le bon raccordement.

2. Installation

2.1. Tools Needed

- M4-Allen Wrench 4mm (#22 on blister pack)
- M6-Allen Wrench 6mm (#21 on blister pack, blue handle)

Installer provides the following tools:

- Med Phillips Screwdriver
- Socket wrench 16mm
- Open end wrench 16mm

2.2. Hardware Included

The following hardware and tools are supplied:

Figure 2-1. Hardware and Tools Supplied on Blister Pack

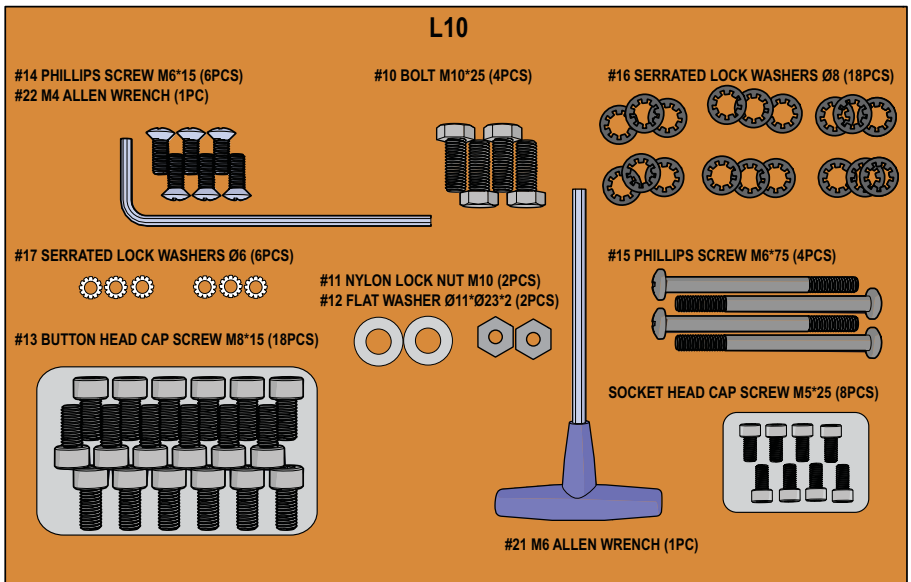



- M6x15 Phillips screw: 6 pieces (#14 on blister pack)
- Serrated lock washers for M6 screws: 6 pieces (#17 on blister pack)
- M8x15 button head cap screws: 18 pieces (#13, bag on blister pack)
- Serrated lock washers for M8: 18 pieces (#16 on blister pack)
- M5x25 Socket Head Cap Screws: 8 pieces (to attach motor cover)

- M10x25 bolts: 4 pieces (#10 on blister pack)
- M10 Nylon Lock Nuts: 2 pieces (#11 on blister pack)
- M10 Flat Washers: 2 pieces (#12 on blister pack)
- M4x75 Phillips screws: 4 pieces (#15 on blister pack)

2.3. Unpacking

Unpacking and installation of the treadmill should be done by a qualified technician. The packaged treadmill is very heavy and weighs 600 lbs (272KG), packaged.

	<p>To avoid injury, use caution when moving and lifting the treadmill during unpacking and assembly.</p>
	<p>Pour éviter toute blessure, faites attention lors du déplacement et du levage du tapis roulant lors du déballage et de l'assemblage.</p>

1. Locate where the treadmill will be used to provide space as shown in Figure 2-2.

Figure 2-2. Free Space Areas

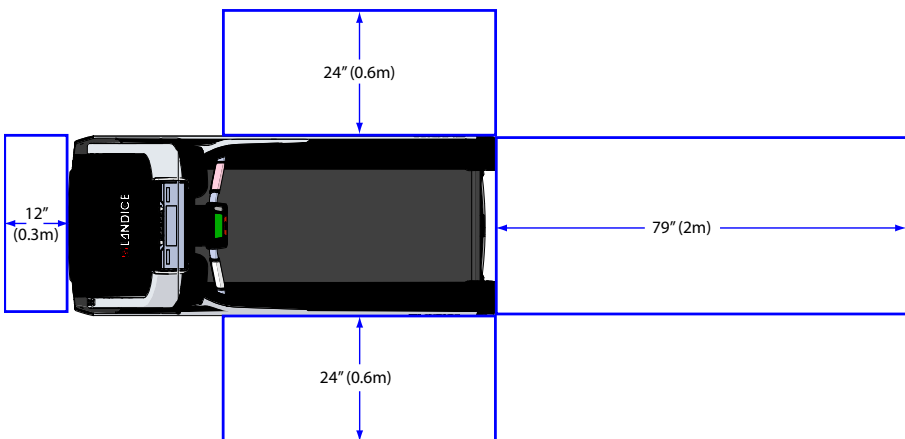

2. Move boxed unit to room where it will be used, cut the straps, and take off the top of the box (Figure 2-3).

Figure 2-3. Open Shipping Box

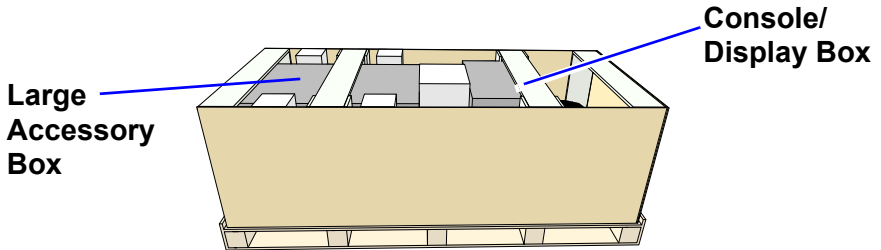

3. Remove wood bracing from inside the box. You will have to slide larger box toward center to remove wood brace covering it (Figure 2-4).

Figure 2-4. Bracing Removal

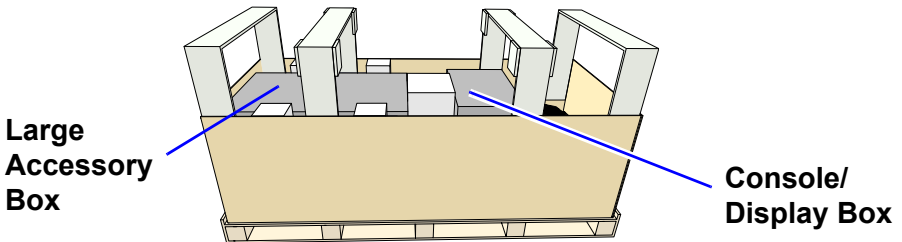

4. Open the large box. Inside you will find:
 - Plastic wrapped blister pack of hardware and tools
 - Handrails
 - Remote Console
 - Cup holder
 - Treadmill Lubricant
 - Line Cord
 - Manual and Warranty Card

Figure 2-5. Large Accessory Box Contents

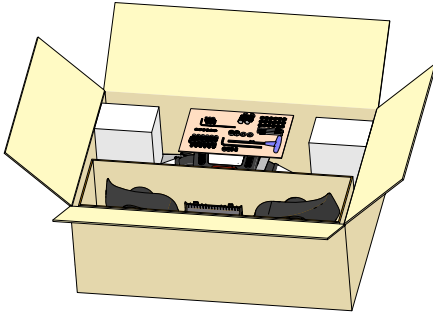

5. Open smaller box. Inside you will find the console/display (Figure 2-6).

Figure 2-6. Console/Display

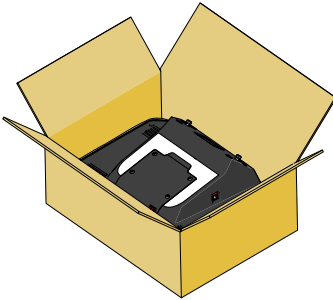

6. Remove Upright from box (Figure 2-7).

Figure 2-7. Packed Upright

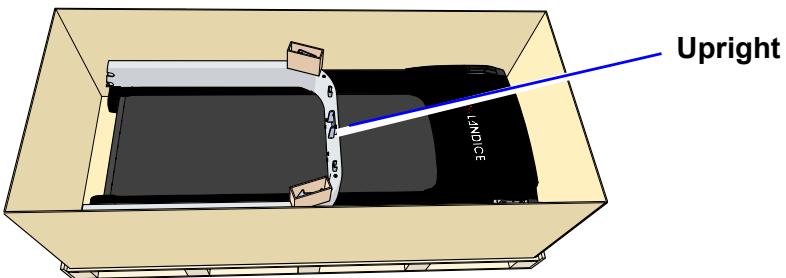

7. Cut open the box and remove bubble wrap (Figure 2-8). Lift motor cover off and set aside.

Figure 2-8. Packed Base

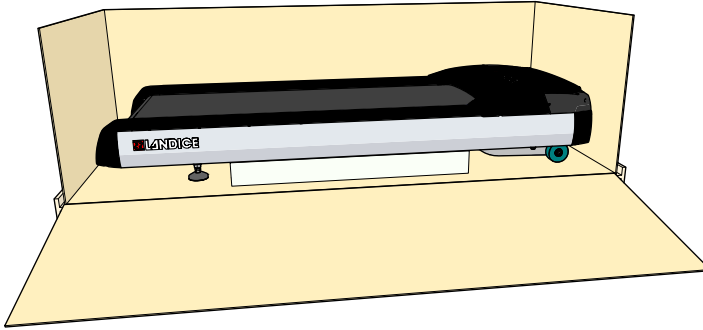

8. Remove the Treadmill base from the box and place where it will be used as determined in Step 1. One person uses the Grab Bar and two people lift at each front corner as shown in Figure 2-9.

Figure 2-9. Base Removal

Lift at corners

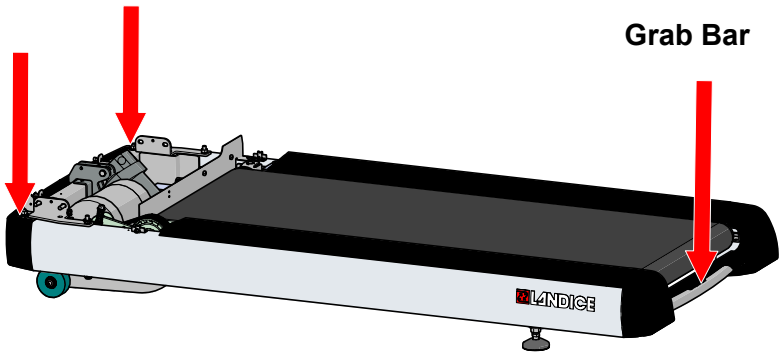

2.4. Assembly

1. On both sides: the M10x165 and M10x180 Hex Head Bolts used to secure the Upright to the Frame are shipped in the Frame, held in place during shipment with 16mm nuts. Remove and discard the nuts and allow bolts to slide down and rest on the floor (Figure 2-10).

Figure 2-10. Bolt Shipping Position

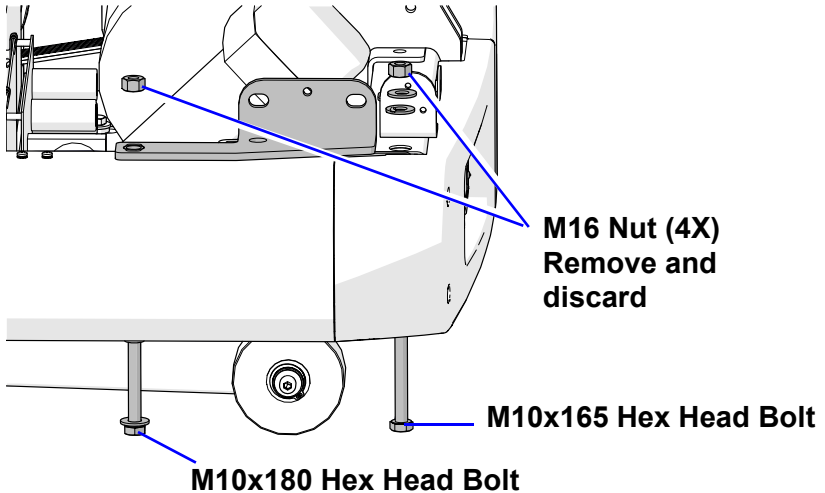

2. Untie wire tie from the Upright and leave wire in place. You will need this to guide the Upper Wire Harness through the Upright Upper Access Hole later.
3. Align the pins on the bottom of the Upright Plate with the holes in the Frame and lower the Upright fully onto the Frame (Figure 2-11).

Figure 2-11. Upright Installation

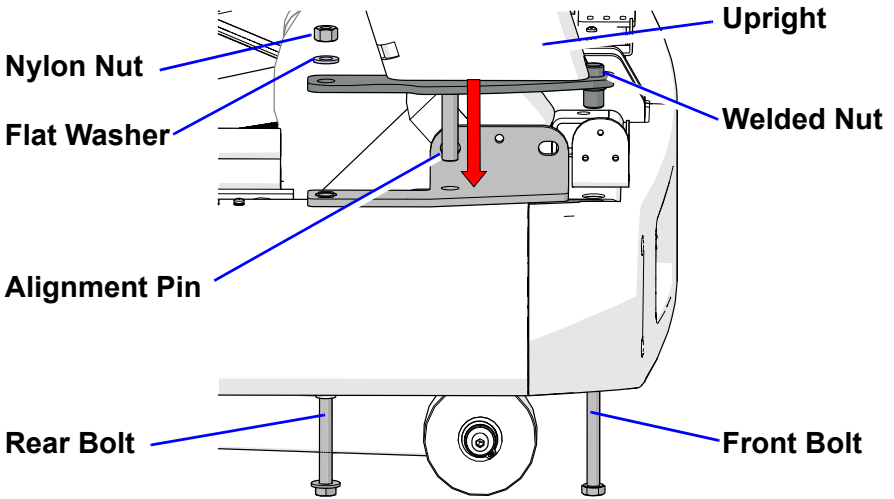

4. Remove the two Nylon Lock Nuts #11 and Flat Washers #12 from the blister pack.
5. On both sides: Push the Rear Bolt up through the Frame and Upright Base Plate and install the Nylon Lock Nuts and Flat Washers. Do not fully tighten at this time.
6. Thread the Front Bolt into the Welded Nut on the Upright Base Plate but do not fully tighten at this time.
7. On both sides: Thread the two M10x25 Hex Head Bolts through Frame Bracket into the Upright as shown in the following figure (Figure 2-12). Repeat steps for opposite side.

Figure 2-12. Upright Side Bolts

M10x25 Hex Head Bolts (4X, from blister pack)

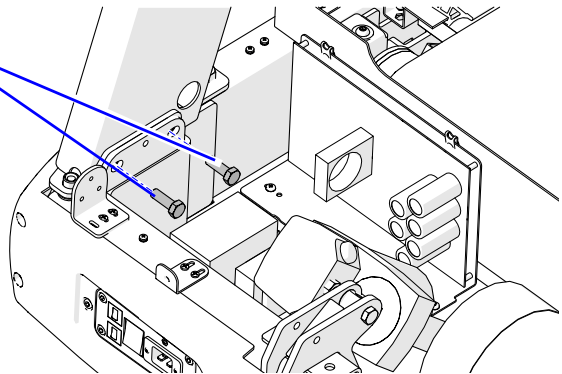

8. Tighten all four M10x25 Hex Head Bolts.
9. Tighten remaining hardware found in Step 1.
10. Slide Remote Console Assembly onto Center Upright Bracket and the End Plates into the Side Brackets as shown in Figure 2-13.

Figure 2-13. Remote Console Assembly Installation

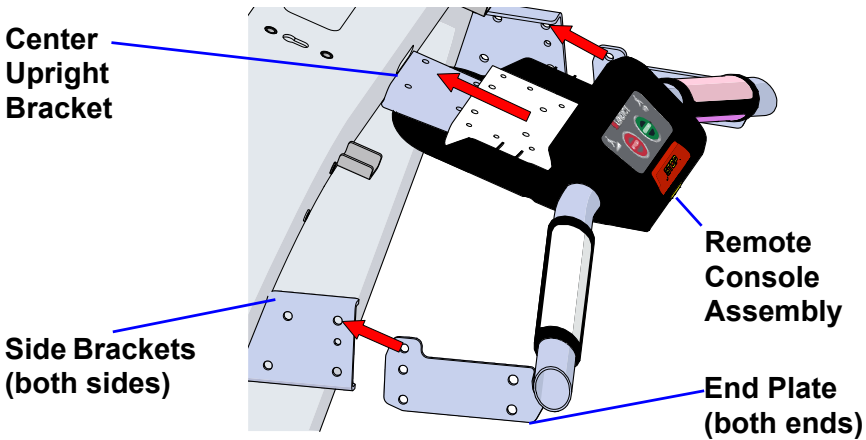

11. Attach the Remote Console Assembly to Center Upright Bracket from the bottom using four M8x15 Socket Head Cap Screws (#13 on blister pack) with the blue (M6) Allen wrench provided on the blister pack. Do not completely tighten (Figure 2-14).

Figure 2-14. Remote Console Assembly Center Upright Bracket Mounting Hardware

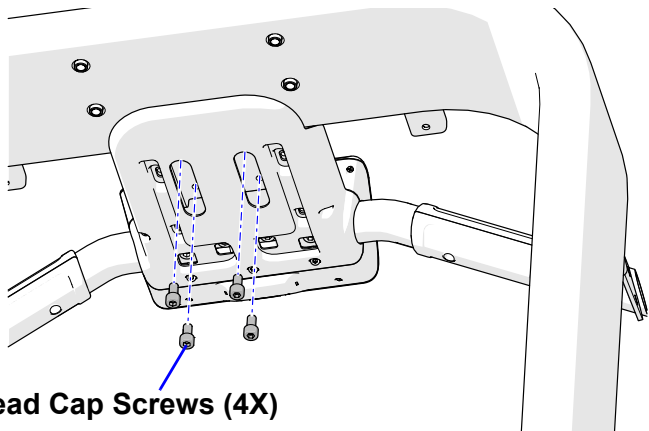

- On both sides: attach the Remote Console Assembly to the Upright Brackets using one M8x15 Socket Head Cap Screw, found on blister pack (Figure 2-15). Secure with 6mm Allen wrench.

Figure 2-15. Remote Console Assembly Plate Hardware (both sides)

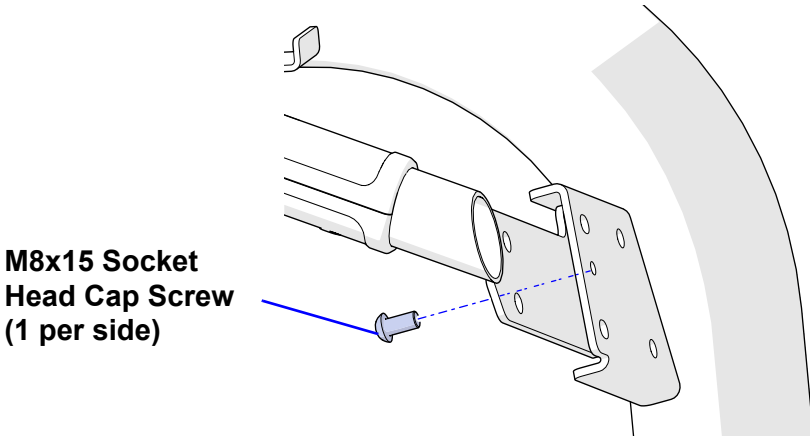

M8x15 Socket Head Cap Screw (1 per side)

- Remove the three M5x15 Socket Head Cap Screws holding the Inner Handrail Covers to each Handrail, using the 4mm Allen wrench, as shown in Figure 2-16 and place them in a safe place for reuse later when the Covers are re-installed.

Figure 2-16. Handrail Inner Cover Hardware (both sides)

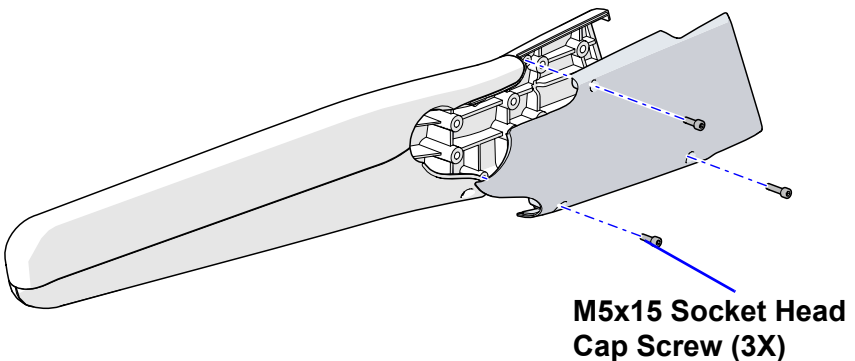

M5x15 Socket Head Cap Screw (3X)

- Loosely attach each Handrail to the Upright Bracket and the Remote Console Assembly End Plates with M8x15 Socket Head Cap Screws and Lock Washers. Tighten all Screws that secure the Remote Console Assembly to the Upright (6 per side, Figure 2-17).

Figure 2-17. Handrail Mounting Hardware

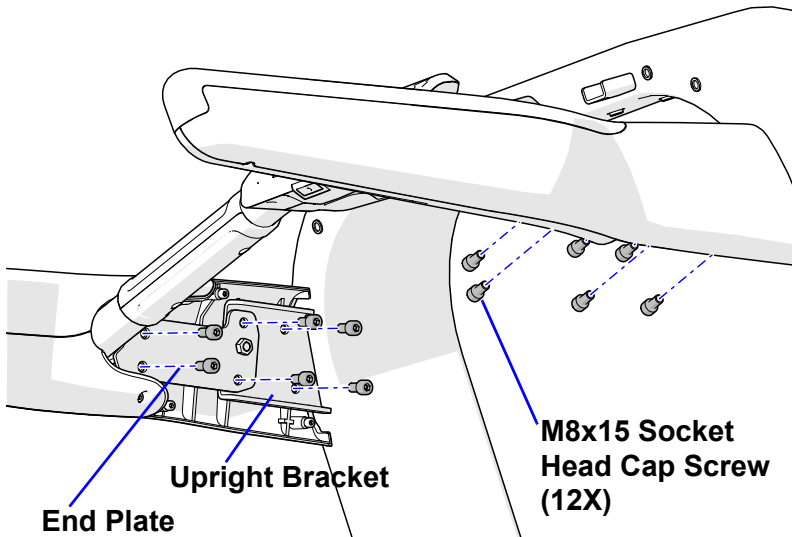

- Install both Handrail Inner Covers with M5x15 Socket Head Cap Screws (3 each side, previously removed in Figure 2-16) using 4mm Allen wrench.
- Place the accessory tray as shown in Figure 2-18. Guide the Ribbon Cable and Pulse Cable (optional) coming from the Lower Control Panel under the cable guide in the accessory tray, out the front of the tray, and up through the hole in the center of the upright.

Figure 2-18. Accessory Tray Installation - Cable Routing

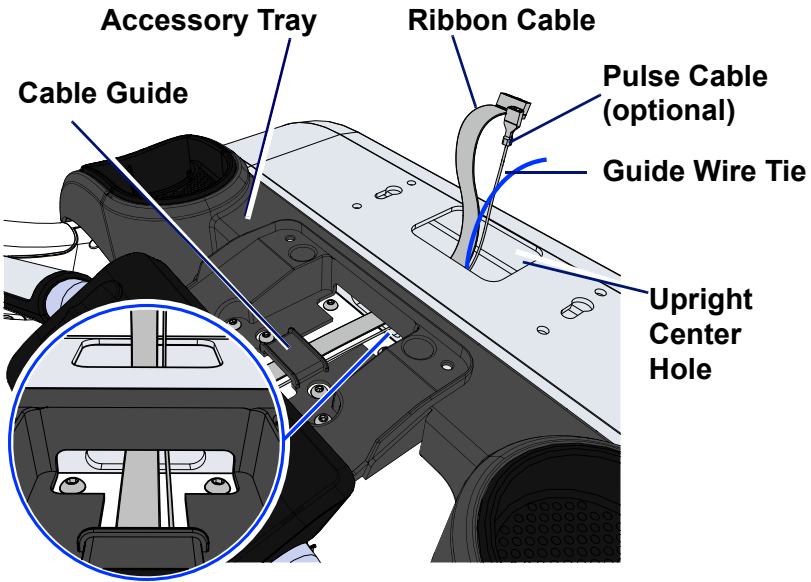

17. Then place the accessory tray over the handrails and secure from the top with (4) M6x16 screws found in the hardware kit, using 5mm hex wrench (Figure 2-19).

Figure 2-19. Ribbon and Pulse Cable Routing and Hardware
Accessory Tray

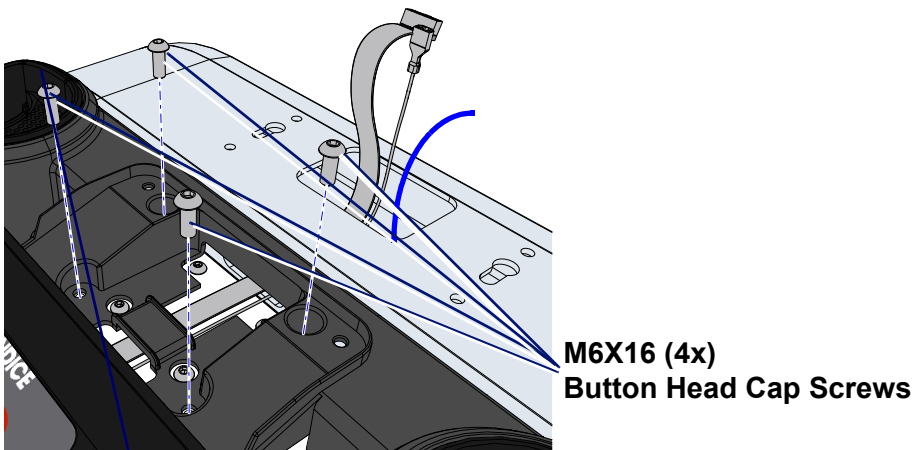

18. Attach accessory tray from below with (2) M6x16 button head cap screws using a 4 mm hex wrench (Figure 2-20).
Tip: Start both screws before tightening.

Figure 2-20. Accessory Tray Installation - Lower Screws

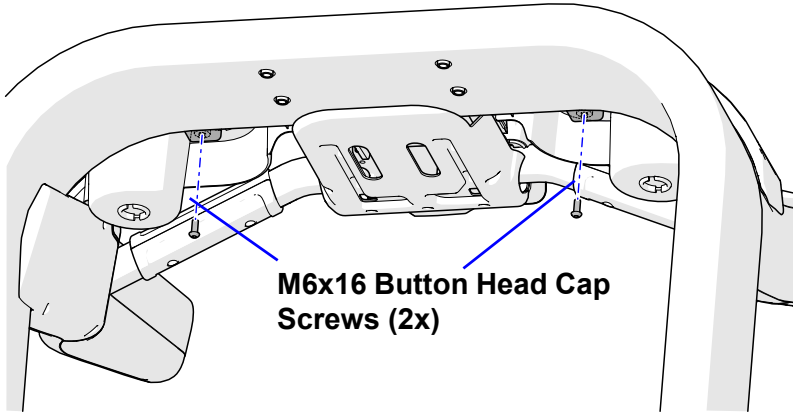

19. Remove Console/Display from box. There are (3) cables coming from the bottom of the Console: the long Upper Wire Harness, the flat ribbon cable, and the optional wireless pulse cable (Figure 2-21).

Figure 2-21. Console/Display Cables

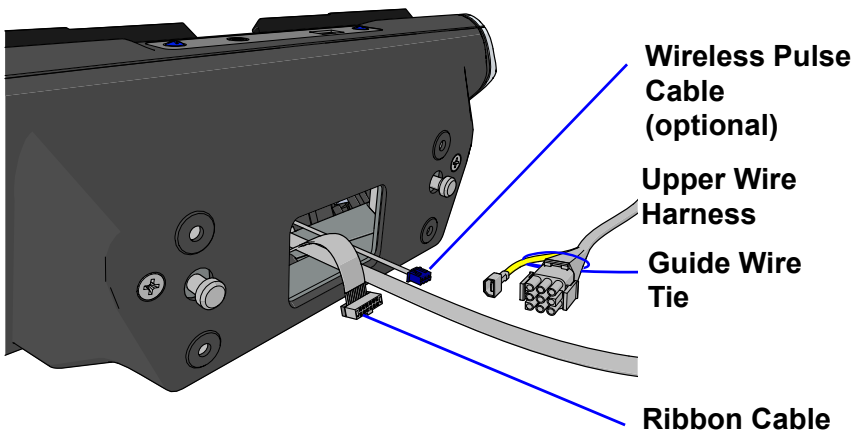

20. Find the guide wire tie coming from the Upright Center Hole. Wrap the end of the wire tie around the Upper Wire Harness (see Figure 2-21).
21. Pull the wire tie from the lower access hole to guide the Upper Wire Harness through the Upright and out of the Upright Cable Routing Hole (Figure 2-22) into the motor pan. Connect ground wire and main harness to lower control board and frame.

Figure 2-22. Upper Wire Harness Routing Path

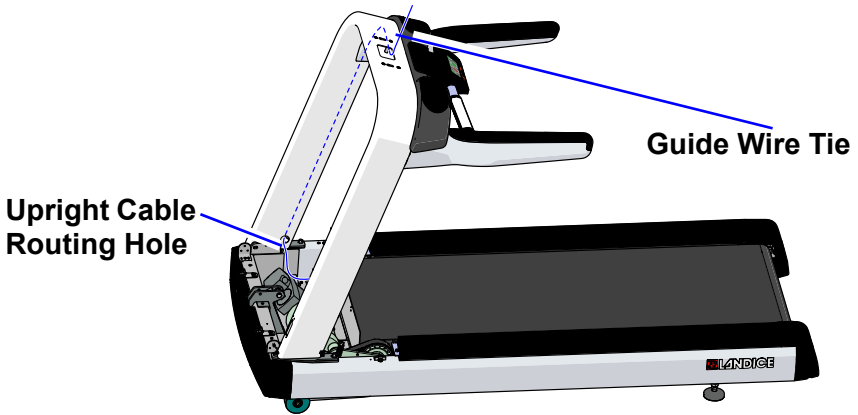

22. Connect the Ribbon Cable and the Pulse Cable (optional) from the Remote Console to the corresponding cables from the Console/Display (Figure 2-23).
23. Ensure cables are not crimped or caught between Console/Display and Upright and engage the studs on the Console/Display in their keyways and slide toward you to lock the Console/Display in place (Figure 2-23).

Figure 2-23. Console Assembly Installation
(cables not shown for clarity)

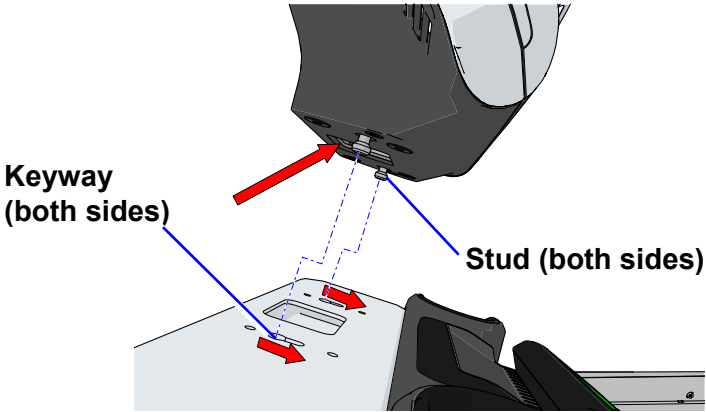

24. Remove four M6X75 button head cap screws from blister pack. Using 4mm Allen wrench, secure Console/Display assembly to upright (Figure 2-24).

Figure 2-24. Console Assembly Bolts

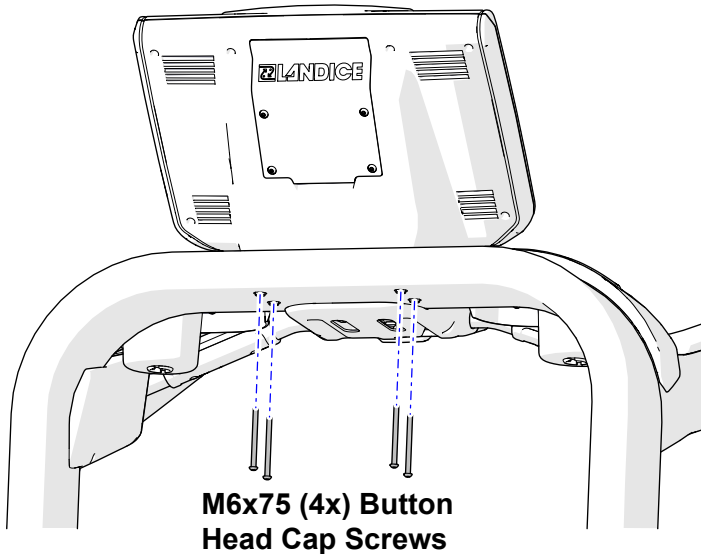

25. Engage the Accessory Tray tabs in the notches of the Remote Console Assembly and snap the Accessory Tray posts into their receivers (Figure 2-25).

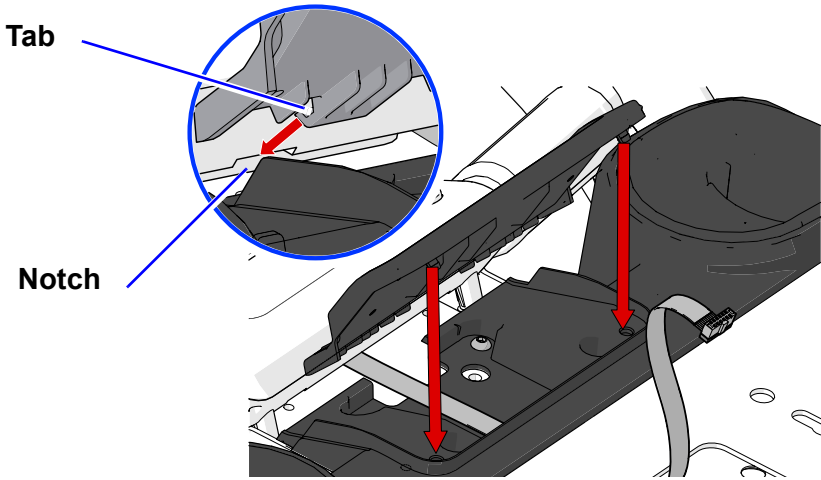
Figure 2-25. Accessory Cover Installation

2.5. Cover Installation

1. Install the Motor Cover using two M5x25 Socket Head Cap Screws, found on blister pack, as shown in Figure 2-26.

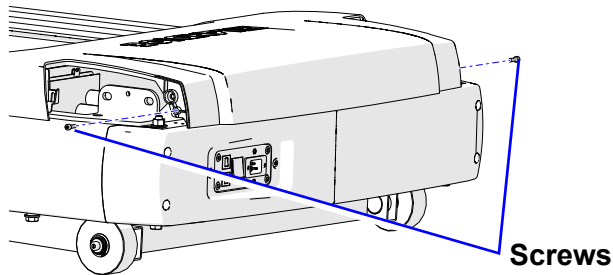
Figure 2-26. Motor Cover Inner Screws

2. Install the Forward Covers found in large accessory box and secure with two M5x25 Socket Head Cap Screws found on blister pack (Figure 2-27). Ensure that you slide the Forward Cover tabs behind the Motor Cover and that the screw holes align, as indicated by the red arrows.

Figure 2-27. Motor Cover Outer Screws

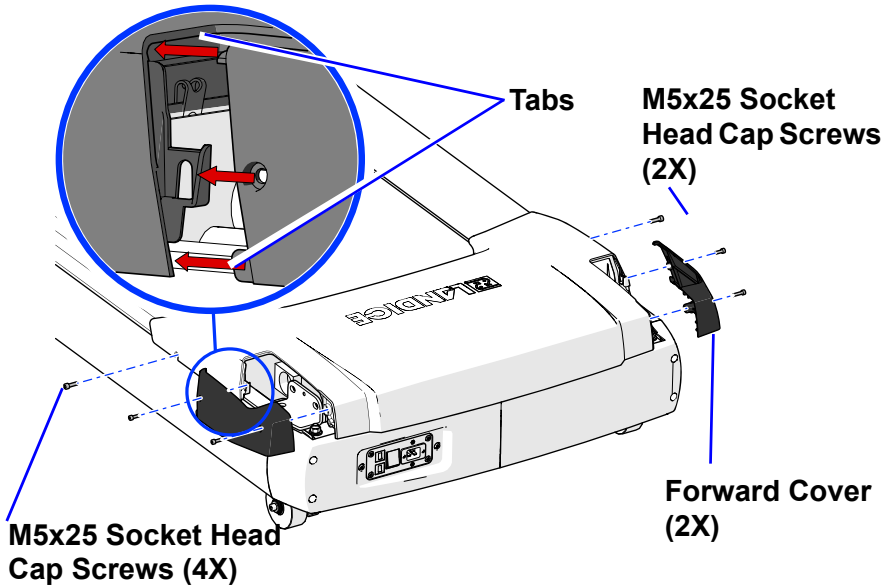

3. Install the four M5x25 Socket Head Cap Screws found on blister pack (Figure 2-27).
4. Start treadmill and walk at 2.5 mph for 20 to 45 minutes, walking from front to back over the entire surface, to properly “walk in” the lubrication.
5. As you walk, test the treadmill by adjusting speed and adjusting incline. Ensure all displays light.
6. After confirming proper treadmill operation, turn the treadmill off by pressing **STOP** twice.
7. The treadmill is now ready for use.

2.6. Leveling Treadmill

1. Ensure that all feet touch the floor: Loosen the 19mm Jam Nut and the 14mm Adjustment Nut using open end or adjustable wrench and turn the Adjustment Nut until the foot touches the floor (Figure 2-28).

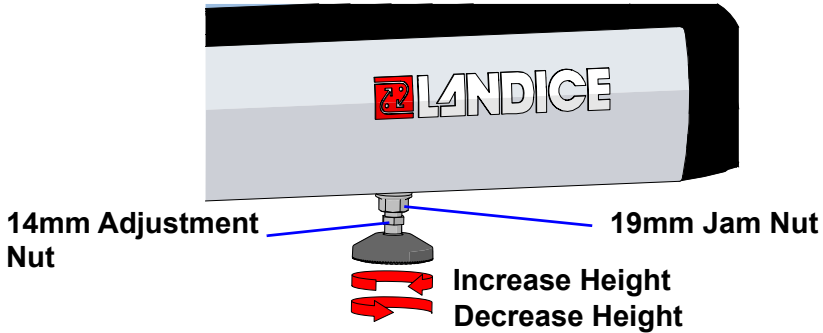

Figure 2-28. Leveling Feet





<p>CAUTION</p>	<p>There must be a minimum of 150 pounds on the treadmill's side steps for the reading to be accurate.</p>
<p>ATTENTION</p>	<p>Il doit y avoir un minimum de 150 livres sur les étapes latérales du tapis roulant pour que la lecture soit précise.</p>

2. Place a level across the rear of the machine and stand in the middle of the running surface, facing the rear of the treadmill. Check if the bubble is centered on the level.
 - If the bubble goes to the right (while standing on treadmill), adjust the left rear foot. Loosen the 19mm nut by turning it clockwise and rest it against the 14mm nut. Turn the 14mm nut clockwise to raise the foot. Stop adjusting the foot when the bubble is centered on the level.
 - If the bubble goes to the left (while standing on treadmill), adjust the right rear foot. Loosen the 19mm nut by turning it clockwise and rest it against the 14mm nut. Turn the 14mm nut clockwise to raise the foot. Stop adjusting the foot when the bubble is centered on the level.

- When the bubble is centered on the level, lock each leveling foot into place by tightening the 19mm nut against the bottom of the frame.

 WARNING	Do not plug treadmill into a surge suppressor or GFI outlet.
 AVERTISSEMENT	Ne branchez pas le tapis roulant dans un suppresseur de surtension ou une sortie GFCI.

- Plug the treadmill power cord into a dedicated power outlet. Ensure that the power cord has plenty of slack and will not be pinched beneath the treadmill as the treadmill elevates up and down.
- Ensure the safety lanyard block is pushed in.

 CAUTION	DO NOT OVER-TIGHTEN or belt, rollers and motor will be damaged.
 ATTENTION	NE PAS SERRER OU NOIR, la ceinture, les rouleaux et le moteur seront endommagés.

2.7. Treadbelt Tensioning

1. Treadbelts are tensioned at the factory prior to shipment and normally need no adjustment. To determine if the treadbelt needs adjustment, straddle the treadbelt by stepping on the straddle covers. Start the treadmill, step on the treadbelt and increase speed to 3mph. Walk on treadbelt and verify that the treadbelt is not slipping. If there is no treadbelt slippage proceed to the next step, otherwise perform the following procedure:



	<p>Tighten only enough to stop slippage. Overtensioning the treadbelt will damage the drive motor, rollers and treadbelt. DO NOT OVERTIGHTEN TREADBELT!</p>
	<p>Ne serrez que suffisamment pour arrêter le glissement. Une contrainte excessive de la ceinture risque d'endommager le moteur d'entraînement, les rouleaux et la ceinture de train. NE SOUHAITEZ PAS TREADBELT!</p>

Figure 2-29. Treadbelt Tensioning Screws



To tighten treadbelt, turn both adjustment bolts indicated by the red arrows in Figure 2-29 (clockwise) exactly the same amount to maintain proper tracking. Failure to turn them equally will affect belt tracking. You are moving the take-up roller further away from the drive roller to tension the treadbelt.

2.8. Treadbelt Tracking

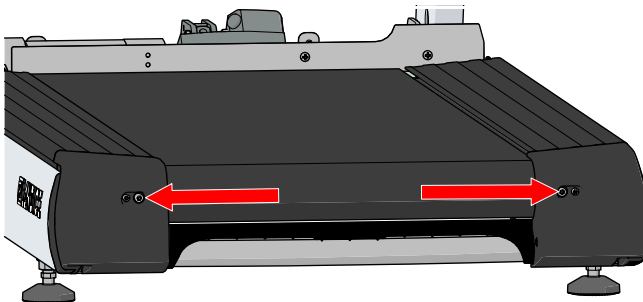
1. Ensure that the Treadbelt tracks properly. Treadbelt tracking is maintained by ensuring that the drive and take-up rollers are parallel, each is at right angles to the frame, so that the treadbelt tension from side to side is equal as shown in the following figure. If the treadbelt is running diagonally, with unequal gaps between the treadbelt and sides then the rollers must be adjusted (see Figure 2-30).

Figure 2-30. Tracking Setup

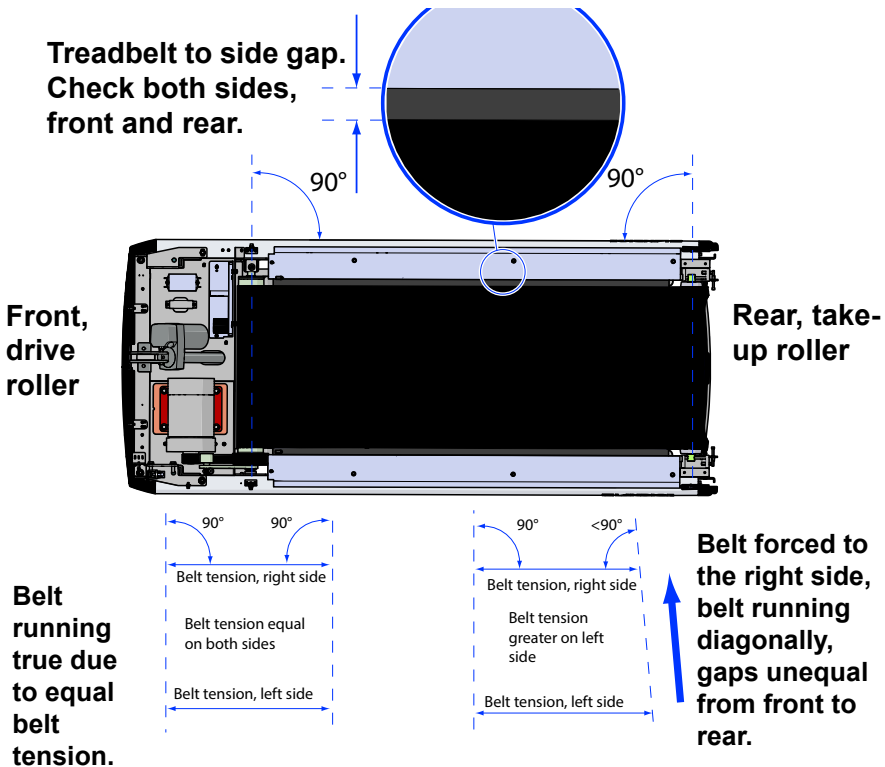

Adjustment is performed using the two adjustment screws (6mm Allen wrench) located at rear of treadmill, see Figure 2-30. The following provides a tracking adjustment example: Treadbelt tracks to the right:

Note: This example assumes that only the take-up roller is out of alignment. You might encounter a situation in which both rollers are out of alignment but the same process applies.

- a. Turn treadmill on, and bring speed up to 2.0 mph.
- b. Using a 9/16" wrench, tighten the right-hand adjustment bolt a quarter-turn.
- c. Loosen the left-hand adjustment bolt a quarter-turn.
- d. Let treadbelt stabilize (rotate for 30 seconds). In this example, the treadbelt will change tracking as shown by the blue arrow due to the increased tension on the right side and the reduced tension on the left. Readjust if necessary.
- e. If normal tracking procedures are not working satisfactorily, repeat the same procedure just performed on the take-up rollers on the drive rollers as discussed in "Treadbelt Tensioning" on page 27.

LANDICE

111 Canfield Avenue, Suite A-1, Randolph, NJ 07869
1-800-LANDICE
U.S. Tel. (+1) 973-927-9010 · Fax (+1) 973-927-0630
International Tel. (+1) 973-927-9010
www.landice.com