

LANDICE

Rehab Treadmill 90 Series Owner's Manual



Part Number: 73060-5

Important Safety Instructions

Read all instructions before using the treadmill.

DANGER

To reduce the risk of electric shock: always unplug the treadmill from the electrical outlet immediately after using and before cleaning.

WARNING

To reduce the risk of burns, fire, electric shock or injury to persons:

- An appliance should never be left unattended when plugged in. Unplug from outlet when not in use, and before putting on or taking off parts.
- Close supervision is necessary when the treadmill is used by or near children or persons with disabilities.
- Use the treadmill only for its intended use as described in this manual. Do not use attachments not recommended by Landice.
- Never operate treadmill if it has a damaged cord or plug, if it is not working properly, or if it has been damaged. Call your dealer or certified service provider immediately for examination and repair.
- Keep the power cord away from heated surfaces. Be sure the cord has plenty of slack and cannot be pinched under the treadmill when it elevates and de-elevates.
- Never operate the treadmill with the motor cover air openings blocked. Keep the air openings free of lint, hair, dust, or debris.
- Do not drop or insert objects into any opening on the treadmill. Be sure no objects are near or beneath the treadbelt when you are using the treadmill.
- Do not use treadmill outdoors.
- Do not operate treadmill where aerosol (spray) products are being used or where oxygen is being administered.
- To disconnect, press **STOP** twice, pull the safety lanyard out, then remove plug from outlet.

WARNING

Failure to observe the following warning statements can result in serious injury!

- Do not use this product without first consulting your doctor if you suffer from any illness, condition, or disability that affects your ability to run, walk or exercise.
- Do not use this product without supervision present if you are suffering from any illness, condition, or disability which affects your ability to run, walk or exercise. Failure to do so can result in serious injury should you fall while the treadbelt is moving.
- Failure to leave ample clearance around the treadmill could cause you to be trapped between the treadmill and a wall if you fall, resulting in burns or other serious injury from the moving treadbelt. **Allow a minimum clearance of 18 inches (46 cm) on each side of the treadmill. Allow a minimum clearance of 6 feet (183 cm) at the rear of the treadmill.**
- Never stand on the treadbelt when starting the treadmill. A sudden start could cause you to lose your balance. Always begin by placing your feet on the side traction strips, straddling the treadbelt, before turning the treadmill on.
- Always wear the safety lanyard clip securely on your clothing while exercising. Failure to do so can result in severe injuries should you accidentally fall while exercising.
- Test the emergency stop safety lanyard regularly by pulling on the cord and ensuring that the treadbelt comes to a complete stop when key is pulled.
- Familiarize yourself with this manual. Be sure you understand operation of the treadmill before use.
- Always follow basic safety precautions when using an electrical appliance.

⚠ WARNING

Connect treadmill to a properly grounded, dedicated electrical outlet only. See the following Grounding Instructions.

⚠ WARNING

This product contains chemicals known to the state of California to cause cancer and birth defects or other reproductive harm.

This product must be grounded. If it should malfunction or break down, grounding provides a path of least resistance for electric current to reduce the risk of electric shock. The treadmill is equipped with a cord having an equipment grounding conductor and a grounding plug. The plug must be plugged into an appropriate outlet that is properly installed and grounded in accordance with all local codes and ordinances.

⚠ DANGER

Improper connection of the grounding connector can result in a risk of electric shock. Check with a qualified electrician/service technician if you are in doubt as to whether the treadmill is properly grounded. Do not modify the plug provided with the treadmill—if it will not fit the outlet, have a proper outlet installed by a qualified electrician.

- 120-Volt Treadmills

Treadmills marked 120 VAC are intended for use with a grounding plug in a nominal 120-volt circuit. Ensure the treadmill power cord is connected to an outlet having the same configuration as the plug. No adapter should be used with 120 VAC treadmills.

- 200 – 250-Volt Treadmills

Treadmills marked 200-250 VAC are intended for use on a circuit having a nominal rating greater than 120V and are factory-equipped with a specific power cord and plug to permit connection to a proper electrical circuit. Ensure the treadmill power cord is connected to an outlet having the same configuration as the plug. No adapter should be used with 200 – 250 VAC treadmills.

If the treadmill must be configured for use on a different type of electrical circuit, qualified service personnel should make the proper connection.

Treadmill Quick Start Guide

Before you Start the Treadmill: Safety

⚠ WARNING

The treadmill will not operate unless the yellow emergency stop Safety Lanyard Block is pushed in. During operation, pulling the safety lanyard pulls the Safety Lanyard Block out, stopping the treadmill. To help prevent injury, always clip the Safety Lanyard Clip to your clothing while using the treadmill, to stop the treadmill if you slip or fall during your workout.



Lower Control Panel

Using the Control Panel

This manual covers the Landice Rehabilitation treadmill control panel. Quick start instructions are included. For detailed instructions, see “Rehab Treadmill Operation” on page 41.

Rehab Treadmill Console



Treadmill Controls: Quick Start Guide

Function	Description
INCLINE	Displays the incline of the treadmill in percent (%).
SPEED	Displays the current speed of the treadbelt in MPH (km/hr in metric mode).
START	Powers up the treadmill. All displays light and the treadbelt begins moving at 0.5 mph (0.8 km/hr in metric mode). The START button will also take the treadmill out of pause mode and resume treadbelt movement.
STOP	Press STOP once to pause the treadmill or twice to turn it off. The statistical information is cleared when the treadmill is turned off.
MANUAL MODE	To manually control the speed and incline of the treadmill, press the button below the word MANUAL .

Treadmill Controls: Quick Start Guide (Continued)

Function	Description
PROGRAMS	To use the built-in and user-defined workout programs: Press the button below the word PROGRAMS at any time to display the programs selection screen. Use arrow to scroll through the built-in and user-defined program previews and select the desired program by pressing ENTER . You are then prompted to enter the program's specific parameters (Maximum Speed, Incline, Time, etc.). Use the numeric keypad or the arrow to select the desired values. Press START to begin the program.
PLUS KEY	Press and hold the (+) to increase incline or speed. Pressing for longer than 2 seconds causes the incline or speed to increase at a faster rate. Release the key when the display shows desired incline or speed.
MINUS KEY	Press and hold to the (-) to decrease incline or speed. Pressing for longer than 2 seconds causes the incline or speed to decrease at a faster rate. Release the key when the display indicates desired incline or speed.
ARROW KEYS	The buttons below the left and right arrows move between display sections or to set values.
EXPRESS 1 EXPRESS 2	EXPRESS 1 controls the Incline and EXPRESS 2 controls the Speed. In conjunction with the numeric keypad this allows you to directly enter a target speed or incline without using the (+/-) keys. Press EXPRESS 1 for Incline or EXPRESS 2 for Speed, then enter the desired value using the numeric keypad. Wait 3 seconds for the treadmill to adjust to the new settings.
The numeric keypad is used to change speed and incline with the EXPRESS keys, enter user settings, and configure programs.	
	

Switching English/Metric Display Units

The treadmill display shows English units (mph for speed, lb for weight) by default.

To switch from English to Metric follow the steps in “Hidden Menus” on page 62 and select **Toggle Units**.

Repeat the same steps to return to English if desired.

Important Safety Instructions	2
Grounding Instructions	4
Treadmill Quick Start Guide.....	5
1. Introduction	11
1.1. Before You Begin	11
1.2. Heart Rate Monitoring	13
1.2.1. What is exercise intensity?	13
1.2.2. What is maximum heart rate?	14
1.2.3. Why should I monitor exercise intensity?	15
1.2.4. How do I determine my Target Heart Rate Zone?	15
1.3. Heart Rate Monitors	16
1.3.1. Wireless Chest Strap Monitoring System	17
1.3.2. Contact Heart Rate Monitoring System	18
1.4. Treadmill Program Capabilities	19
2. Installation	21
2.1. Tools Needed	21
2.2. Unpacking	21
2.3. Assembly	23
2.3.1. Base Assembly Instructions	23
2.3.2. Medical Rail Installation	24
2.3.3. Optional Handrail Installation	29
2.3.4. Accessory Tray Installation	29
2.3.5. Leveling Feet.....	36
2.3.6. Treadmill Tensioning	37
3. Rehab Treadmill Operation	41
3.1. Rehab Control Panel	41
3.2. Display Features	43
3.3. Using the Treadmill	45
3.4. Using the Built-in Programs.....	45
3.4.1. Description	45
3.4.2. Running a Built-In Program	46
3.5. User Programs	48
3.5.1. Learn Mode	49
3.6. Specific Goal Programs.....	50
3.7. Heart Rate Control Program.....	50
3.7.1. Built-in HRC Program.....	51
4. Fitness Testing	53
4.1. Introduction.....	53
4.2. Balke Fitness Test.....	53
4.3. Firefighter (Gerkin) Fitness Test.....	55

5. Maintenance and Troubleshooting	59
5.1. Cleaning.....	59
5.2. Maintenance	59
5.2.1. Lubrication	59
5.2.2. Treadbelt Tracking Adjustment.....	60
5.2.3. Treadbelt Tensioning	60
5.2.4. Motor Drive Belt Tensioning	61
5.2.5. Service Checklist	61
5.3. Self-Diagnostics.....	61
5.4. Hidden Menus.....	62

1. Introduction

Landice has placed over 100,000 treadmills, ellipticals and bikes in the harshest commercial environments around the world, where our fitness equipment has proven its strength and durability. Landice products are designed by a world-class development team whose innovation defines the leading edge of high-end fitness.

This manual covers the Rehab treadmill. Be sure you understand how to operate your treadmill's control panel before using the treadmill. See "Rehab Treadmill Operation" on page 41.

1.1. Before You Begin

Please do the following before you start to exercise on your treadmill:

- **Register your treadmill.** Landice backs your treadmill with a strong warranty. For the factory to respond if your treadmill has a problem, we need your warranty information on file. Register online at the link below.
<http://www.landice.com/support/product-registration>
- Ensure that a suitable electrical outlet is available:
 - LTD Treadmills: 120VAC/15 amp dedicated circuit or optional 220VAC/10 amp dedicated circuit
- Select the proper location. The treadmill should be installed in a climate-controlled room. See "Installation" on page 21.
- Familiarize yourself with the features of the treadmill, shown in the following figures.

Figure 1-1. Treadmill Features and Controls



Table 1-1 Treadmill Features and Controls

Item	Description
Control Panel	Provides workout displays and controls. Control panels vary by model.
USB Port	Provides a charging port for most devices up to 600mA. Service use only: allows treadmill software to be updated.
Accessory Tray	Provides accessory storage.

Table 1-1 Treadmill Features and Controls (Continued)

Item	Description
Bottle Holder	Holds bottles/cups.
Pulse Grips (2)	Detects pulse when hands are placed on the grips, allowing treadmill to calculate and display heart rate.
<p>Lower Control Panel Controls</p> <p>The lower control panel is located between the pulse grips. This area provides easy-to-reach controls for stopping, resuming or changing speed or incline during your workout.</p>	
Speed Adjustment	Increases/decreases treadbelt speed when pressed up/down. Performs the same function as the SPEED (+/-) keys on the control panel.
STOP Button	Press STOP once to pause the treadmill or twice to turn it off. Statistical information is cleared when treadmill is turned off.
Safety Lanyard Block	Provides the connection for the safety lanyard. The treadbelt will not move unless the safety lanyard block is pushed in.
Incline Adjustment	Raises/lowers the front of the treadbelt when pressed up/down. Performs the same function as the INCLINE (+/-) keys on the control panel.

1.2. Heart Rate Monitoring

This section provides basic concepts of heart rate monitoring so you can better understand how to use it to reach the fitness level you desire.

1.2.1. What is exercise intensity?

Exercise intensity is simply a measure of how hard you are working at a given time during exercise. The ACSM, the world's leading medical and scientific authority on sports medicine and fitness, recommends that every individual involved in an exercise program know how hard his/her body is working during exercise.

Your heart provides key information for determining how intensely you are working during exercise. Your heart rate (how many times your heart beats per minute) is really an efficiency rating for your entire body. The number of times your heart beats during each minute of exercise is a measurement of the intensity of the exercise. If your heart rate is low, exercise intensity is low; if your heart rate is high, your exercise intensity is high.

1.2.2. What is maximum heart rate?

Maximum Heart Rate (MHR) is the maximum attainable heart rate your body can reach before total exhaustion. True maximum heart rate is measured during a fatigue or “stress” test. This test must be done in a clinical setting and is not practical or accessible for most people.



The use of this formula assumes no underlying heart or respiratory disease or other condition, which could be adversely affected by exercise. Consult your doctor before using this chart!

Your maximum heart rate can be established with a high degree of accuracy using the following simple formula:

Estimated Maximum Heart Rate = 220 minus your age.

If John is 35 years old, what is his estimated maximum heart rate?

John’s estimated maximum heart rate is: $220 - 35 = 185$

185 beats per minute is the estimated maximum number of times John’s heart can beat before his body would fatigue or “max out.” This number is extremely helpful because it indicates the absolute highest exercise intensity John can handle before his body wears out. The ACSM says that during exercise, John should keep his heart rate below his maximum so that he will not become exhausted and have to quit. In fact, the ACSM gives John a specific percentage range of his maximum heart rate to exercise in, known as his Target Heart Rate Zone.(THRZ).

1.2.3. Why should I monitor exercise intensity?

Your heart is the most important muscle in your body and, like all muscles, must be exercised regularly to remain strong and efficient. According to fitness experts, exercise is more effective when you work out in a specific heart rate range or zone. This is referred to as your Target Heart Rate Zone (THRZ) and is reflected by the number of heart beats per minute. This zone can vary greatly depending on your age, fitness level and various other factors. If your heart rate is too low during exercise, your body reaps little or no benefit. This means you're not likely to see the results you want, like weight loss or increased endurance. If your heart rate is too high during exercise, you may tire too quickly, become fatigued or even run the risk of injury.

Monitoring exercise intensity helps you to stay at a level of exercise that allows you to accomplish your goals. In fact, the ACSM recommends that, in order to get the most benefit from your cardiovascular exercise, you should work within your THRZ for at least 20 to 60 minutes per workout, 3 to 5 times per week. Knowing your exercise intensity (THRZ) will allow you to work at the right level of exercise to accomplish this.

1.2.4. How do I determine my Target Heart Rate Zone?

Your THRZ represents the minimum and maximum number of times your heart should beat in one minute of exercise. The ACSM recommends that all individuals should work within a Target Heart Rate Zone of 60% to 85% of Maximum Heart Rate. This means that your heart rate during exercise should not fall below 60% or rise above 85% of your maximum heart rate. Let's look at John from our earlier example. John is 35 years old, so his estimated maximum heart rate is $220 - 35$, or 185 beats per minute (bpm). The ACSM recommendation is that John should exercise between 60% and 85% of 185 beats per minute to stay in his THRZ. Let's determine John's THRZ:

- John's estimated maximum heart rate: 185 bpm
- Lower target limit: $185 \text{ (MHR)} \times 0.6 = 111 \text{ bpm}$
- Upper target limit: $185 \text{ (MHR)} \times 0.85 = 157 \text{ bpm}$

- John's target heart rate zone: 111-157 bpm

111-157 beats per minute is the range or zone for John's heart rate during exercise in order to achieve his goals. If John is a beginning exerciser, he'll want to stay at the low end of his THRZ. If John is a more advanced exerciser, he may want to work at the higher end of his THRZ to challenge himself more. The following list shows the different intensity levels within a target heart rate zone:

- Beginner: 60% of MHR
- Weight Loss: 75% of MHR
- Aerobic: 85% of MHR

1.3. Heart Rate Monitors

Heart rate monitors are built into the treadmill's pulse grips, and a wireless chest strap monitor is available as an option.

Exercising too hard can put you at a risk for injury. A heart rate monitor reminds you of the safe and effective heart rate intensity at which you should exercise and warns you if your workouts go too far.

If you want to reach your exercise goals, it's important to stay in your THRZ during workouts. A heart rate monitor provides a reminder of the intensity and quality of each workout session.

Landice heart rate monitors are used to monitor your level of exercise intensity during workouts. Pulse meters have a high margin for error. Manual pulse measurements during exercise can result in errors as high as ± 15 beats per minute, with the risk of potential error increasing as heart rate increases.

1.3.1. Wireless Chest Strap Monitoring System

Note: The wireless chest strap is optional.

The Wireless Chest Strap transmitter works best against bare skin. Because sweat (salt water) is an electrical conductor, the transmitter will work over a T-shirt if the shirt is wet with sweat. If you are having trouble getting an accurate pulse reading, try wearing the belt against bare skin.

Figure 1-2. Wireless Chest Strap Transmitter



Center the transmitter on the chest as high under the pectoral muscles (breasts) as possible. Tighten the strap so that the belt is as tight as possible without being uncomfortable.

1.3.2. Contact Heart Rate Monitoring System

The Contact Heart Rate Monitoring System is designed for use at walking speeds. A natural running motion involves using your arms to maintain balance. Because the Contact Heart Rate Monitoring System requires your arms to remain stationary, we recommend using the pulse grips at speeds of less than approximately 4 mph (6.4 km/h) or the fastest speed at which you are comfortable walking.

The Contact Heart Rate Monitoring System can be used in place of the wireless chest strap to perform any of the following functions:

- Monitor your Time in Zone
- Heart Rate Control (HRC) program adjustment
- Help you maintain your Target Pulse

To use the Contact Heart Rate Monitoring System:

1. Switch to any screen that shows Pulse.
2. Grab the pulse grip portion of the center rail. When you place your hands on the grips the display flashes. The pulse will “beat” briefly and then display your heart rate. Your heart rate will be continuously monitored while your hands remain on the grips.

The HRC programs make speed and elevation adjustments to maintain your target heart rate while your hands remain on the grips. If you remove your hands the HRC programs will not change speed or elevation until you place your hands on the grips.

Note: If you are wearing the wireless chest strap, the heart rate from the pulse grips overrides the wireless signal from the chest strap while your hands are on the pulse grips. When you release the grips, the treadmill uses the wireless chest strap signal for pulse calculation.

1.4. Treadmill Program Capabilities

The treadmill has the following program capabilities:

- **Built-in Programs:** You enter the program's maximum time, speed and incline. 5 Built-in Programs. See page 45.
- **User-Defined Programs:** A User-Defined Program looks and runs exactly like a Built-In Program. The primary difference between Built-In and User-Defined Programs is customization. User-Defined Programs allow you to manually edit individual segments. User Programs. See page 48.
- **Specific Goal Programs:** The numeric keypad is used to enter Time and Distance. Goal Programs. See page 50.
- **Heart Rate Control (HRC) Programs:** The heart rate program will automatically vary the speed and incline based upon your target heart rate. This target training maximizes your workout performance while minimizing your workout time. See page 50.
- **Fitness Tests:** The Fitness Tests will measure your fitness level based on your age, gender, and performance. Your Fitness level is calculated using different protocols. See "Fitness Testing" on page 53.

2. Installation

2.1. Tools Needed

- Socket set with 3/8" socket, 1/2" socket, and 9/16" socket
- Open end wrenches 14mm and 19mm, or adjustable open end wrench
- Hex wrenches: 4mm, 5mm, 6mm
- Cross-tip screwdriver
- Razor blade knife

2.2. Unpacking

Unpacking and installation of the treadmill should be done by a qualified technician. The packaged treadmills are very heavy and weigh as follows:

- L7 models: 360 lb, packaged
- L8 models: 435 lb, packaged



To avoid injury, use caution when moving and lifting the treadmill during unpacking and assembly.

Note: Move the shipping crate/pallet to location of final assembly. Allow 3-5 feet working space to safely remove box and pallet.

1. Remove strapping from box and pallet. Use caution, straps may be under tension.
2. Using a razor knife carefully cut the box just above the staple line on all four sides shown in Figure 2-1. Remove box and discard.
3. The treadmill and final assembly components including Hardware kit for both models are held together with strapping. Remove these straps using caution as they may be under tension.

Installation

4. Carefully lift and remove upright tower and assembly component boxes from treadmill base. Place these items safely aside for assembly. (See “Assembly” on page 23.)
5. Position yourself at end of treadmill running surface and using both hands carefully lift and slide treadmill off the pallet to left or right. Repeat process at opposite (heavy end). Remove pallet and discard.

CAUTION

Be careful! Straps are under tension.

CAUTION

To avoid damaging the treadmill, DO NOT cut through the center of the box.

Figure 2-1. Cut Line

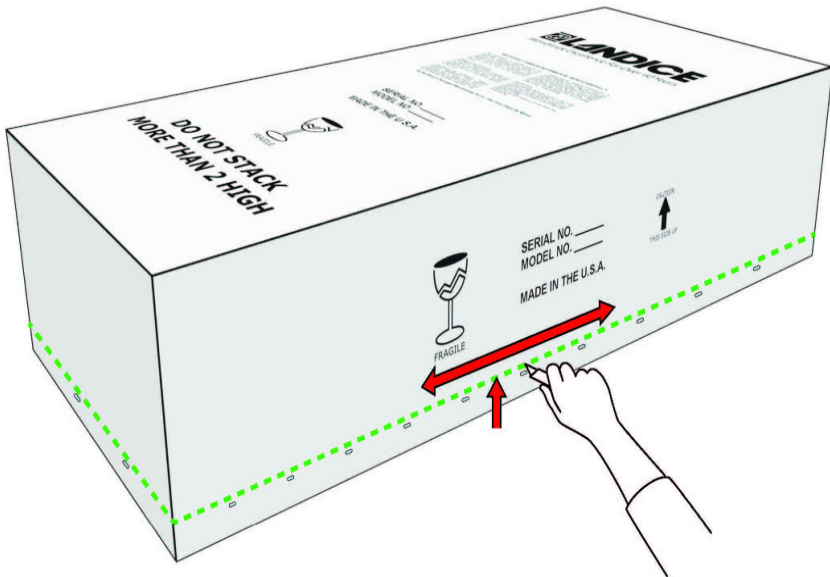

2.3. Assembly

⚠ WARNING

Failure to leave ample clearance at the rear of the treadmill could result in the user becoming trapped between the treadmill and the wall should the user accidentally trip and fall while exercising.

Locate the plastic bag that contains the Owner's Manual and the 90 Series Hardware Kit.

• **90 Series Hardware Kit contains:**

- Handrail screws-12x
- Console screws-4x
- Cup holder screws-6x

• **Medical Rail Hardware:** The medical rail hardware is attached to the medical rail: (2x) 5/16" bolts and (2x) 5/16" lock washers (Figure 2-5).

• **Frame Hardware:** Frame hardware, (4x) 1/4x20 self-tapping screws are started in the frame at the appropriate mounting points (Figure 2-5).

2.3.1. Base Assembly Instructions

1. Position the base where the treadmill is to be located:
 - Allow a minimum clearance of 18 inches (46 cm) on each side of the treadmill.
 - Allow a minimum clearance of 6 feet (183 cm) at the rear of the treadmill.

Note: Do not remove the wire tie protruding from Upright Center Hole on upright. You will need this to guide the upper wire harness down through the upright in "Accessory Tray Installation" on page 29.

- Use a 3/8" socket to remove three bolts from each side of the upright bracket on the frame. Slide the upright down over both brackets (Figure 2-2). Upright legs may require slight compression to properly fit between the upright brackets. Secure each side using three bolts per side starting with the inside bolts first, then the outside bolt. Tighten all securely. The right side is shown in the detail.

Figure 2-2. Upright Installation

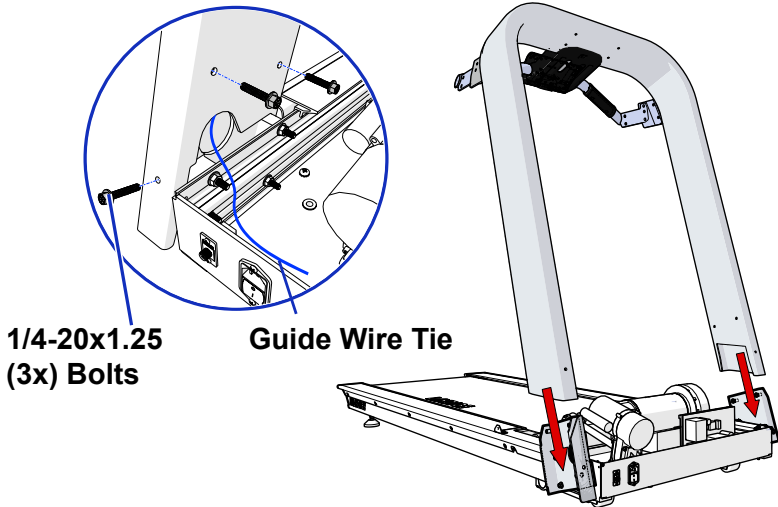

- Proceed to either "Medical Rail Installation" below or 2.3.3 "Optional Handrail Installation" as appropriate for your treadmill.

2.3.2. Medical Rail Installation

Tools needed:

- 4mm Allen Wrench
- 6mm Allen Wrench
- 7/16" and 1/2" open end wrench
- Cross Tip Screwdriver

Parts provided:

- 2-Medical Rails (Left and Right)
 - 2 Medical Rail Brackets located inside medical rail cover box
 - 2 Medical rail covers: left and right
 - 12 Medical rail cover screws, M8x16, found in the 90 Series Hardware Kit
 - 2- 5/16" bolts to attach Medical Rail to Medical Rail Bracket with 2-5/16" lock washers - found in Medical Rail
 - 4- 1/4x20 self-tapping screws to mount Medical Rail to Frame - found in frame
1. Locate both Medical Rail Brackets (Figure 2-3), insert them into both ends of the Crossbar and secure them in place using 1/4x20 hex head screws and 7/16" socket to Crossbar.

Figure 2-3. Medical Rail Bracket Installation

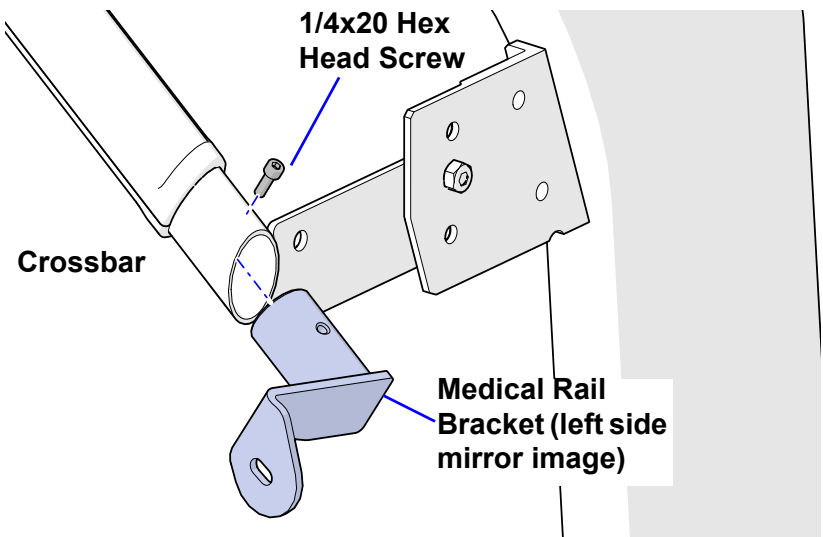

2. Attach Medical Rail to Medical Rail Bracket (Figure 2-4) using 5/16" Hex Bolt with lock washer and 1/2" open end wrench. Bolt should be aligned and secured toward the inside of slot (toward crossbar) as shown in Figure 2-4.

Figure 2-4. Medical Rail Bolt

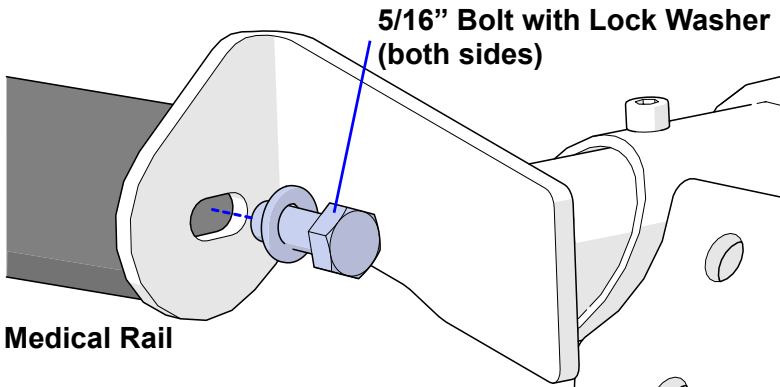

3. Attach Medical Rail to Frame (Figure 2-5) using 1/4"x20 self-tapping screws with long cross tip screwdriver.

Figure 2-5. Medical Rail to Frame Attachment Points

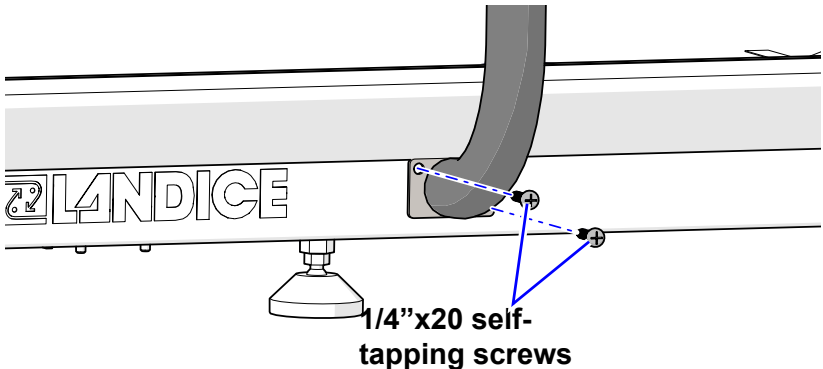

4. Separate the Covers as shown below (Figure 2-6).

Figure 2-6. Medical Rail Covers

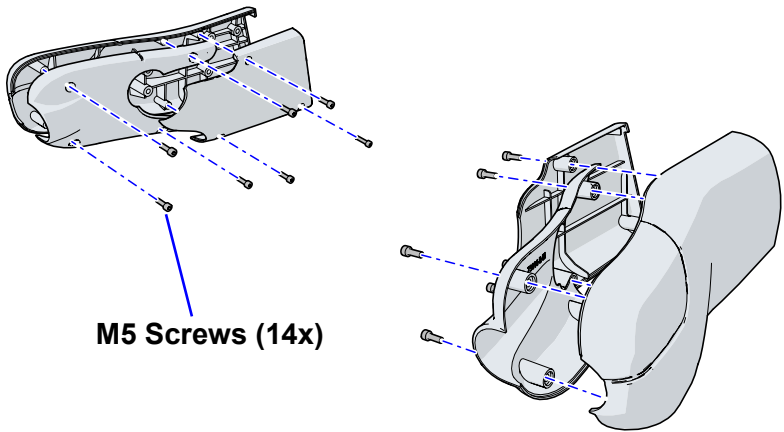

5. Remove (7) M5 socket head cap screws holding each medical rail cover assembly together. Separate each set of covers for installation, attaching hardware will be reused. (Figure 2-7).

Figure 2-7. Outer Cover Mounting Points

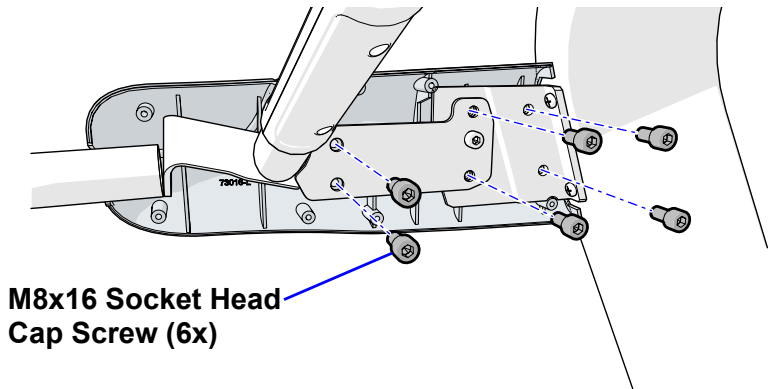

6. Begin with left outside cover installation by inserting the (6) M8x16 Socket Head Cap Screws (found in 90 series hardware kit) through the upright mounting bracket into the outside cover corresponding threaded holes. Be certain to start all (6) screws by hand prior to tightening. Repeat steps for right outside cover installation.

Figure 2-8. Inner Covers Installation

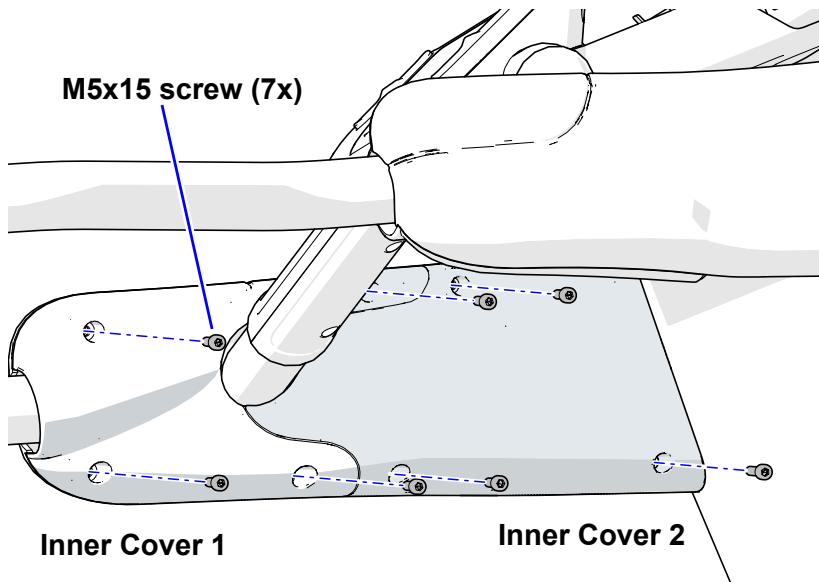

7. Attach inner left Cover 1 using (4) M5 socket head cap screws removed during Medical Rail Cover disassembly. (Figure 2-8).
8. Attach inner left Cover 2 using (3) M5 socket head cap screws removed during Medical Rail Cover disassembly. (Figure 2-8).
9. If the inner and outer covers do not align properly, it may be necessary to reposition the Upper Medical Rail 5/16" Hex Bolt (Figure 2-3) outward (away from crossbar) to achieve proper alignment.
10. Repeat steps 6, 7 and 8 to attach right side outer and inner covers.

2.3.3. Optional Handrail Installation

1. Using a 4mm hex wrench, remove (3) M5X15 screws from each inner handrail cover. Slide the handrail onto the bracket found on the upright and secure with (6) M8x15 socket head cap screws found in the 90 Series Hardware Kit. Repeat on other side. (Figure 2-9).

Figure 2-9. Optional Handrail Installation

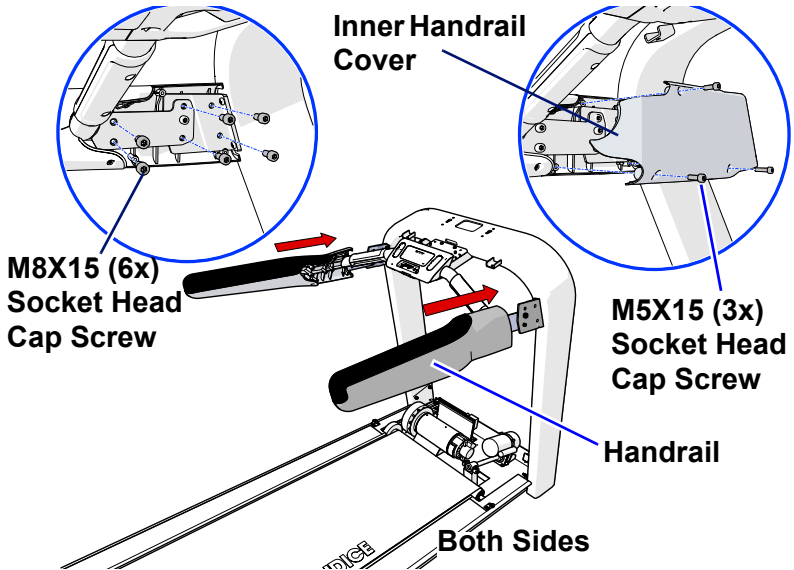

2. Install the inner handrail covers on both sides with (3) M5x15 socket head cap screws using the 4mm hex wrench.

2.3.4. Accessory Tray Installation

1. Place the accessory tray as shown in (Figure 2-10). Guide the Ribbon Cable and Pulse Cable (optional) coming from the Lower Control Panel under the cable guide in the accessory tray, out the front of the tray, and up through the hole in the center of the upright.

Figure 2-10. Lower Control Panel Cables

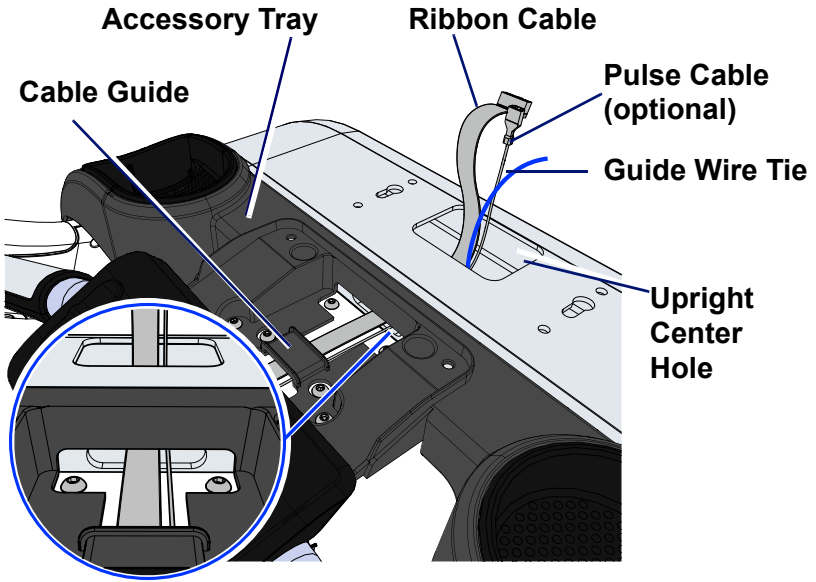

2. Then place the accessory tray over the handrails and secure from the top with (4) M6x16 screws found in the hardware kit, using 5mm hex wrench.

Figure 2-11. Accessory Tray Installation - Upper Screws

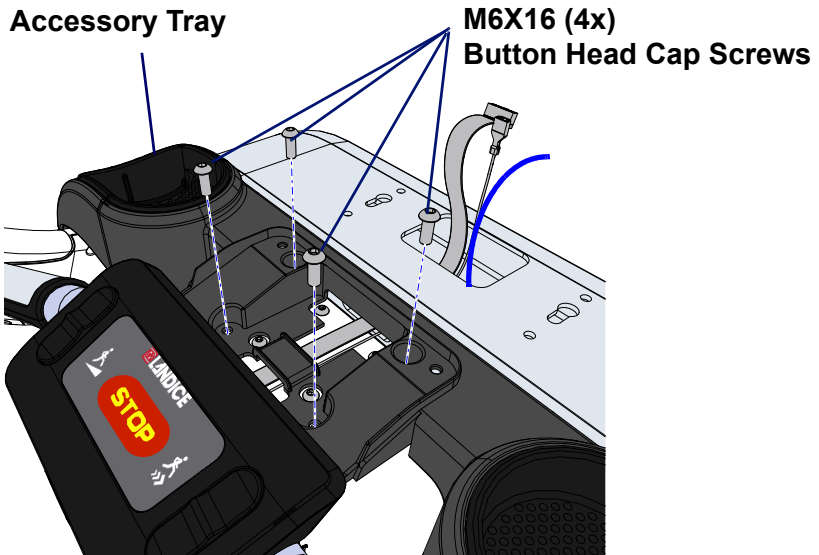

3. Attach accessory tray from below with (2) M6x16 button head cap screws using a 5mm hex wrench. (Figure 2-12).
Tip: Start both screws before tightening.

Figure 2-12. Accessory Tray Installation - Lower Screws

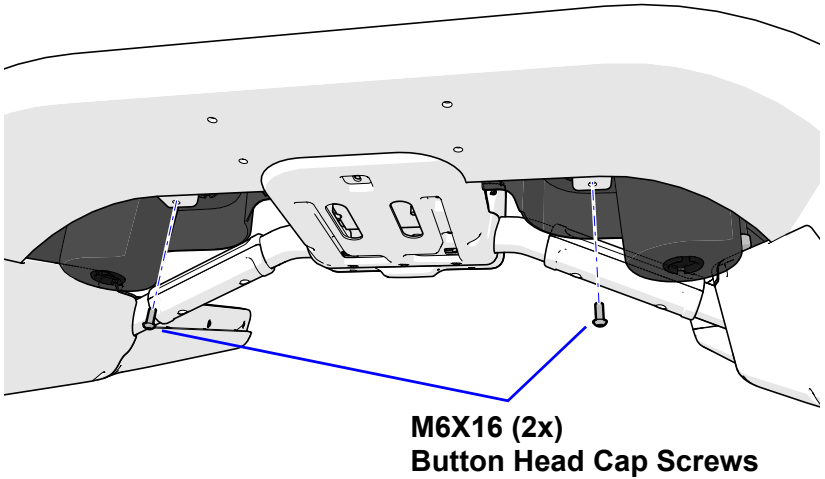

4. Engage the tray tabs in the notches of the accessory tray. Rotate the accessory tray as shown to snap the posts into their receivers. (Figure 2-13).

Figure 2-13. Accessory Tray Tabs

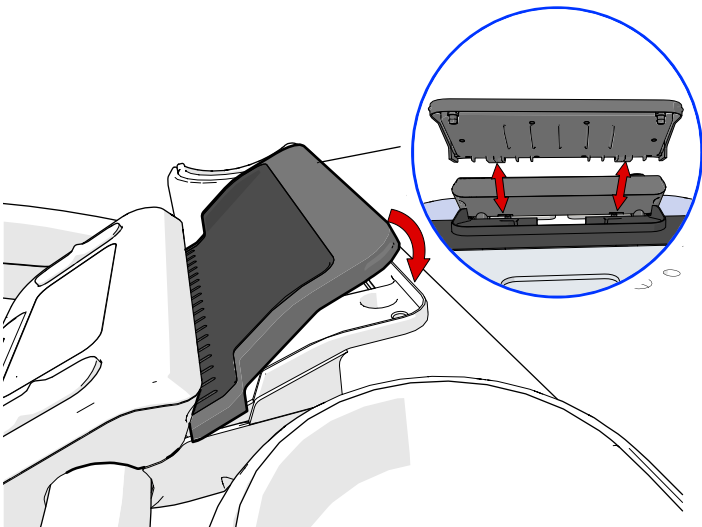

5. Remove Display Console from box. There are (3) cables coming from the bottom of the Console: the long Upper Wire Harness, the flat ribbon cable, and the optional wireless pulse cable. (Figure 2-14).

Figure 2-14. Display Console Cables

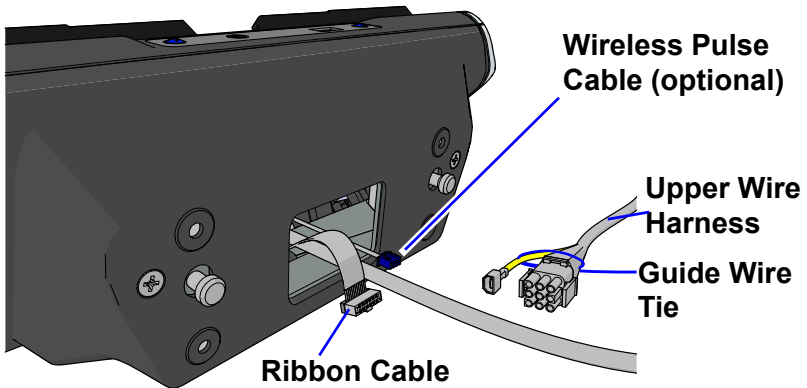

6. Find the guide wire tie coming from the Upright Center Hole. Wrap the end of the wire tie around the Upper Wire Harness (see Figure 2-14).
7. Pull the wire tie from the lower access hole to guide the Upper Wire Harness through the upright and out of the lower access hole (Figure 2-15) into the motor pan.

Figure 2-16. Console Assembly Installation

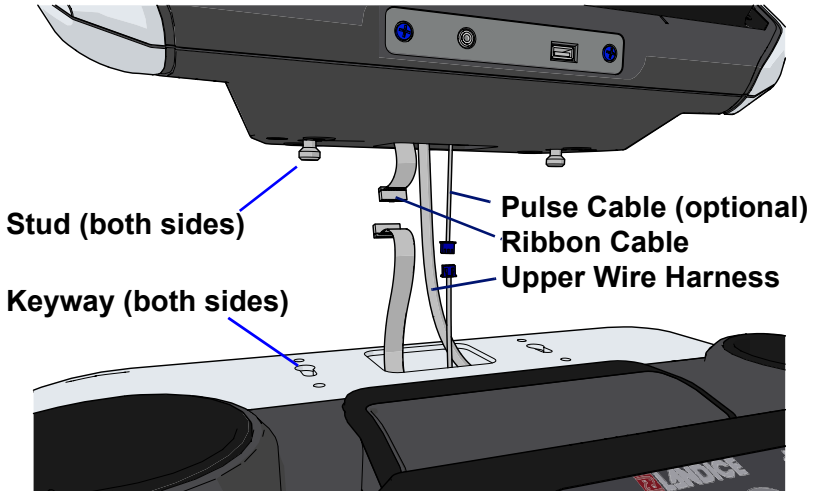

10. Remove power cord from motor pan and plug into receptacle at front of treadmill.
11. Run the Upper Wire Harness behind the Elevation Motor (opposite screw end, Figure 2-18) and connect it to the Motor Control Board.
12. Push ground wire from upper harness to the grounding cable wire coming from the motor pan.

Figure 2-17. Base Grounding Point

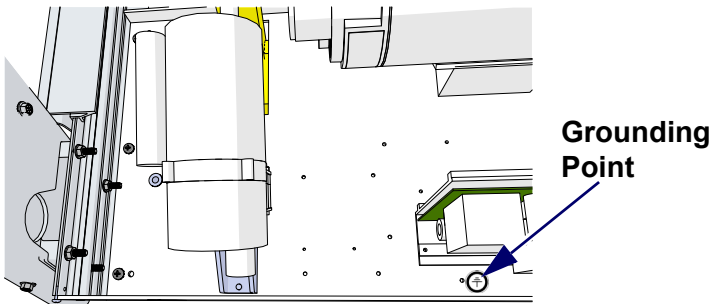
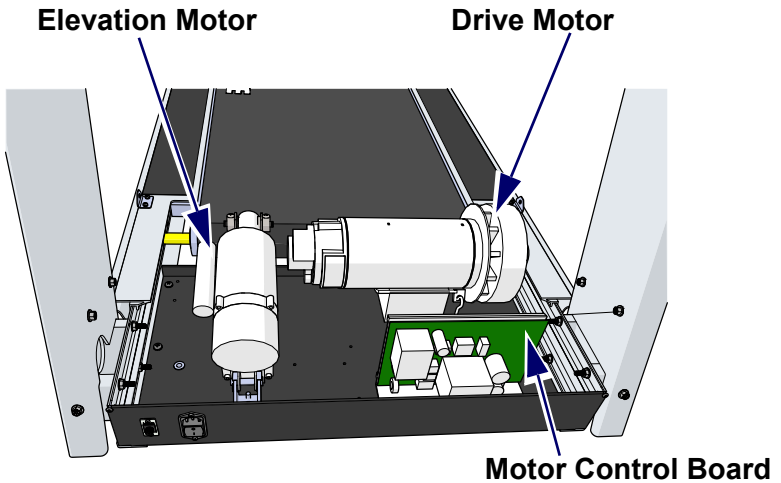
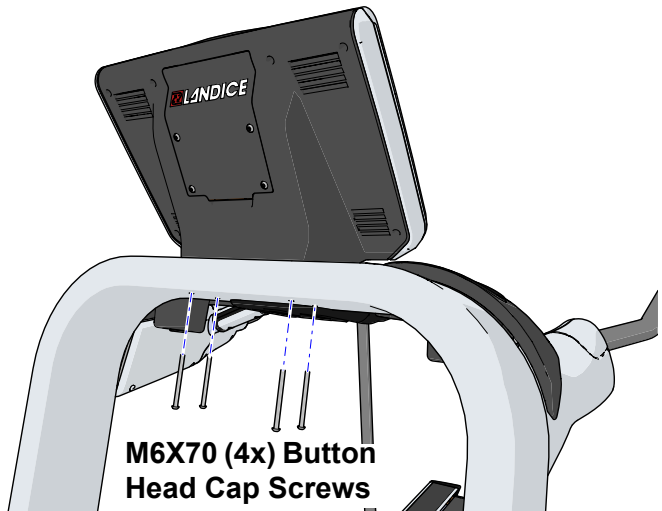

Figure 2-18. Motor Wiring Connections

13. Using (4) M6x70 button head cap screws from the 90 Series Hardware Kit and a 5mm hex wrench, secure Display Console assembly to upright. (Figure 2-19).

Figure 2-19. Console Assembly Bolts

2.3.5. Leveling Feet

1. Confirm that all treadmill feet are touching the ground. If necessary, loosen the 19mm and 14mm nuts using open end or adjustable wrench, until foot touches the floor. (Figure 2-20).

Figure 2-20. Leveling Feet

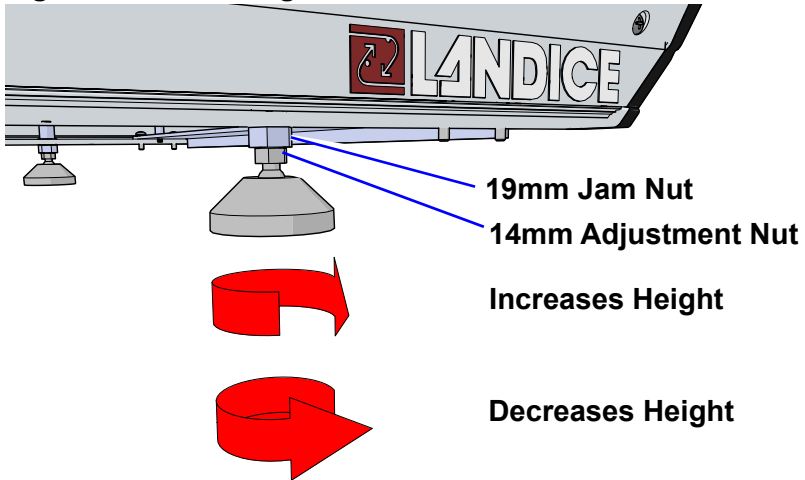

2. Place a level across the rear of the machine and stand in the middle of the running surface, facing the rear of the treadmill. Check if the bubble is centered on the level.
 - If the bubble goes to the right (while standing on treadmill), adjust the left rear foot. Loosen the 19mm nut by turning it clockwise and rest it against the 14mm nut. Turn the 14mm nut clockwise to raise the foot. Stop adjusting the foot when the bubble is centered on the level.
 - If the bubble goes to the left (while standing on treadmill), adjust the right rear foot. Loosen the 19mm nut by turning it clockwise and rest it against the 14mm nut. Turn the 14mm nut clockwise to raise the foot. Stop adjusting the foot when the bubble is centered on the level.
3. Confirm that the bubble is centered on the level.

4. Lock each leveling foot into place by threading the 19mm nut until it touches the bottom of the frame. Turn the 19mm nut counterclockwise and 14mm nut clockwise using an open end wrench to lock each foot into place.

2.3.6. Treadmill Tensioning

1. Before checking treadbelt tension, make sure treadmill is level. (See steps 1 through 4.) At proper tension you should be able to place your hand between the belt and deck and reach the center of the treadmill (Figure 2-21).
 - If you cannot reach the center, the belt is too tight.
 - If your hand reaches past the center, the belt is too loose.

Figure 2-21. Treadbelt Tension Check

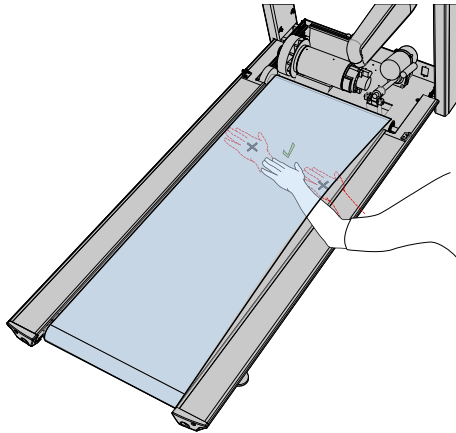

2. To install the motor cover, remove (4) 8-32x1 cross head screws from the frame (Figure 2-22). Tilt motor cover between uprights and place over motor pan. Using the cross head screws you just removed from the frame, install the motor cover.

Figure 2-22. Motor Cover Screw Locations

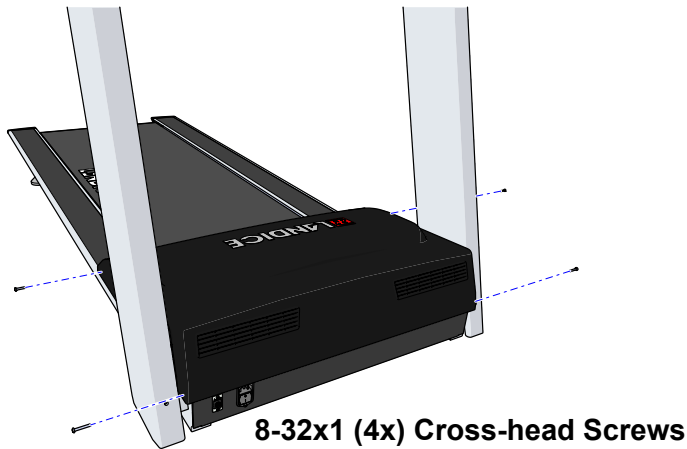

WARNING

Do not plug treadmill into a surge suppressor or GFI outlet.

3. Plug the treadmill power cord into a dedicated power outlet. Ensure that the power cord has plenty of slack and will not be pinched beneath the treadmill as the treadmill elevates up and down.
4. Turn on the power switch located next to the power cord and make sure the safety lanyard block is pushed in. Start the treadmill and increase speed to 2 mph. Check that the treadbelt is tracked (centered) and not moving off to one side. If belt is going toward one side, follow tracking instructions in step 9. If belt is tracked (centered) correctly, proceed to walk on the treadmill at 2 mph. If belt feels like it is slipping under your feet, follow tension instructions in step 8.
5. When belt tension and tracking are both correct, move to the next step.
6. Start treadmill and walk at 2 mph for 20 minutes, walking from front to back over the entire surface, to properly “walk in” the lubrication.

7. As you walk, test the treadmill by adjusting speed and incline. Ensure all displays light.
8. The treadbelt is tracked (centered) and tensioned by the take-up screws located at the back of the treadmill (Figure 2-23). If the treadbelt is too loose (slipping as you walk), turn both screws clockwise by 1/4 turn to tighten using the 9/16" socket.



DO NOT OVER-TIGHTEN the belt. The rollers and motor can be damaged.

9. If the treadbelt does not track straight, adjust speed to 3 mph and tighten the screw on the side to which the belt is pulling by 1/4 turn. Allow time for belt to adjust, approximately 2-3 minutes. Adjust by 1/4 turn as necessary to achieve proper tracking. If more than 3/4 turn is necessary, loosen the opposite side by 1/4 turn.
10. Recheck tension and tracking to confirm the adjustments.

Figure 2-23. Treadbelt Tensioning Take-up Screws

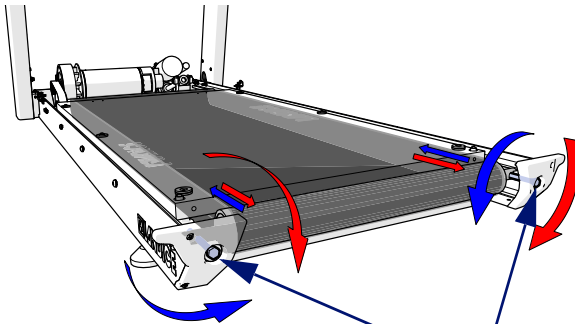

Treadbelt Take-up Screws (2x)

11. After confirming proper treadmill operation, turn the treadmill off by pressing **STOP** twice.
12. Your treadmill is now ready for use.

3. Rehab Treadmill Operation

3.1. Rehab Control Panel



Table 3-1 Control Panel Functions

Function	Description
INCLINE	Displays the incline of the treadmill in percent (%).
SPEED	Displays the current speed of the treadbelt in MPH (km/hr in metric mode).
START	Powers up the treadmill. All displays light and the treadbelt begins moving at 0.5 mph (0.8 km/hr in metric mode). The START button will also take the treadmill out of pause mode and resume treadbelt movement.
STOP	Press STOP once to pause the treadmill or twice to turn it off. The statistical information is cleared when the treadmill is turned off.
MANUAL MODE	To manually control the speed and incline of the treadmill, press the button below the word MANUAL .

Table 3-1 Control Panel Functions (Continued)

Function	Description
PROGRAMS	To use the built-in and user-defined workout programs: Press the button below the word PROGRAMS at any time to display the programs selection screen. Use arrow to scroll through the built-in and user-defined program previews and select the desired program by pressing ENTER . You are then prompted to enter the program's specific parameters (Maximum Speed, Incline, Time, etc.). Use the numeric keypad or the arrow to select the desired values. Press START to begin the program.
PLUS KEY	Press and hold the (+) to increase incline or speed. Pressing for longer than 2 seconds causes the incline or speed to increase at a faster rate. Release the key when the display shows desired incline or speed.
MINUS KEY	Press and hold to the (-) to decrease incline or speed. Pressing for longer than 2 seconds causes the incline or speed to decrease at a faster rate. Release the key when the display indicates desired incline or speed.
ARROW KEYS	The buttons below the left and right arrows move between display sections or to set values.
EXPRESS 1 EXPRESS 2	EXPRESS 1 controls the Incline and EXPRESS 2 controls the Speed. In conjunction with the numeric keypad this allows you to directly enter a target speed or incline without using the (+/-) keys. Press EXPRESS 1 for Incline or EXPRESS 2 for Speed, then enter the desired value using the numeric keypad. Wait 3 seconds for the treadmill to adjust to the new settings.
The numeric keypad is used to change speed and incline with the EXPRESS keys, enter user settings, and configure programs.	
	

3.2. Display Features

Workout information is provided on the Statistics and Heart Rate screens shown below. To toggle between these screens during your workout, use the arrow keys. Table 3-2 provides information about each item displayed.

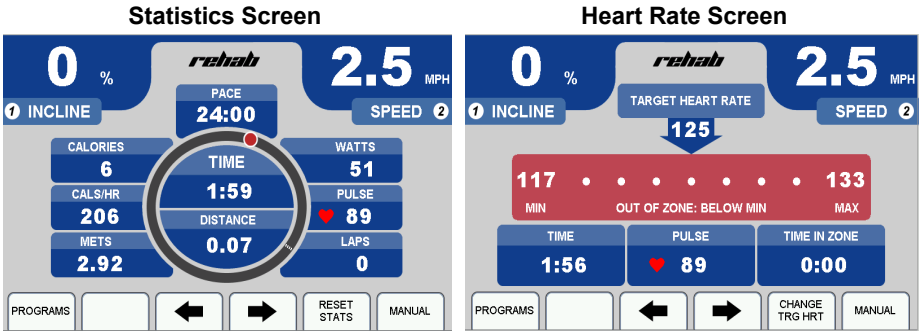

Table 3-2 Display Features

Feature	Description
TIME	Time logged on treadmill, displayed as Minutes:Seconds
DISTANCE	Miles logged on treadmill (kilometers when in metric)
PACE	Time to complete 1 mile (1 kilometer when in metric)
CALORIES	Total calories burned, based on entered user weight
CALS/HR	Approximate calories used per hour, based on user weight
METS	Current MET level, based on user weight / incline / speed. One MET is the energy consumed at rest by the average adult.
LAP (Progress)	1/4-mile (400 meter in metric) track and Lap Indicator
LAPS (Counter)	Number of laps completed
WATTS	Measures the rate of energy conversion by using calories per hour.

Table 3-2 Display Features (Continued)

Feature	Description
PULSE	Current heart rate
TIME IN ZONE	Time spent in zone. The zone is ± 8 beats from target heart rate.
IN ZONE	User's heart rate is within 8 beats of the target heart rate
OUT OF ZONE	User's heart rate is outside zone (more than 8 beats above or below target heart rate)
ABOVE MAX	User's heart rate is above the maximum desirable heart rate
MAX	Maximum allowable heart rate to remain in zone
TARGET HR	Target heart rate (user-defined in Heart Rate Status screen)
MIN	Minimum allowable heart rate to remain in zone
BELOW MIN	User is below minimum allowable heart rate in zone
PROGRAMS	Location for all programs.
RESET STATS	Clears all statistics and resets them to zero.
MANUAL	Exits a program and provides manual control over speed and incline.
CHANGE TRG HRT	Allows the Target Heart Rate to be selected and resets the minimum and maximum heart rate zone.

3.3. Using the Treadmill

1. Make sure you have read and understand this owner's manual before beginning.
2. Plug the treadmill power cord into its outlet.
3. Straddle the treadbelt with one foot on each traction strip.
4. Press **START**. The power-up screen is displayed.
5. After 3 seconds display will show 0.0 mph.
6. Enter your weight using the numeric keypad or arrows. Press **ENTER** or wait 3 seconds to advance to the first of the motivational screens.
7. The treadmill is now ready to use. You can vary the speed or incline, if desired, by using the **SPEED (+/-)** and **INCLINE (+/-)** keys or **EXPRESS 2** and **EXPRESS 1** keys.



3.4. Using the Built-in Programs

3.4.1. Description

The 5 Built-in Programs differ in speed and incline. Each program lets you select a maximum speed, incline, and time (5 to 99 minutes). (Intervals Program requires a minimum speed and incline.) The treadmill will not go above the maximum number unless manually overridden. Each program has 20 segments of equal time, beginning with 3 warm-up segments and ending with 2 cool-down segments. For example, a 40-minute program contains 20 2-minute segments.

*Programs can be removed as an option. See "Hidden Menus" on page 62..

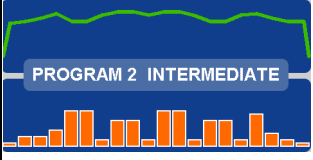
Table 3-3 Built-In Programs

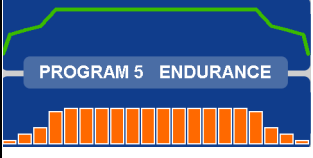
Screen	Program Description
 <p>PROGRAM 1 FAT BURN</p>	<p>FAT BURN: This program features two elevation peaks along with gradual changes in speed. The overall goal is to raise heart rate, maintain the raised heart rate for most of the workout, then gradually bring heart rate down during the last 2 cool down segments.</p>
 <p>PROGRAM 2 INTERMEDIATE</p>	<p>INTERMEDIATE: This program features 5 elevation peaks matched to changes in speed. The overall goal is to vary heart rate by elevating and lowering it several times, providing a challenging cardiovascular workout.</p>
 <p>PROGRAM 3 ADVANCED</p>	<p>ADVANCED: This program features high elevations combined with top speeds. The overall goal is to raise heart rate using speed and elevation for an advanced cardiovascular workout.</p>
 <p>PROGRAM 4 INTERVALS</p>	<p>INTERVALS: This program features high speeds and elevations alternating with low speeds and elevations. The overall goal is to vary your workout, taking you from peak level to recovery 8 times throughout the workout.</p>
 <p>PROGRAM 5 ENDURANCE</p>	<p>ENDURANCE: This program features a maximum speed with maximum elevation. The overall goal is to raise heart rate with speed and elevation for the ultimate cardiovascular workout.</p>

3.4.2. Running a Built-In Program

1. Start a workout as outlined in “Using the Treadmill” on page 45.
2. Press **PROGRAMS** to display the Programs selection screen.

3. Select a built-in program by using the arrow to scroll through the list, then press **ENTER**. You are prompted to enter the following program parameters:
 - **Maximum Speed:** This scales the speed curve to the maximum speed entered.
 - **Maximum Incline:** This scales the elevation curve to the maximum incline entered.
 - **Program Time:** Sets the total length of time you want the program to run.
 - **Minimum Speed/Incline:** INTERVALS Program only.
4. Enter the Maximum Speed using the numeric keypad or the arrow to select a value, then press **ENTER** or wait 3 seconds.
5. Enter the Maximum Incline using the numeric keypad or the arrow to select a value, then press **ENTER** or wait 3 seconds.
6. Enter Program Time using the numeric keypad or the arrow keys, then press **ENTER** or wait 3 seconds. The time should be at least 5 minutes and not more than 99 minutes.
7. Press **START** to begin your workout. The Program Progress Detail screen displays your current segment speed, incline and remaining time.
8. To view other segments, press and hold **ENTER** for 3 seconds. Use the arrow keys to move left or right. To exit, press **ENTER**.
9. Press **ENTER** or use the arrow keys at any time to view any of the other motivational screens during your program, including the Program Profile screen to see a program overview. When viewing a motivational screen other than the Program Progress Detail screen during a segment change, the display temporarily shows the Program Progress Detail screen then returns to the original screen. During a segment change, the speed and/or incline window will flash if there is a change in either.

3.5. User Programs

Rehab treadmills can store up to 5 individual, modifiable user-defined program profiles.

A user-defined program looks and runs exactly like a built-in program, but it can be customized to suit the user. Unlike the built-in programs, user-defined programs allow editing of individual segments as well as the number of segments.

1. Press the button below PROGRAMS to display the Programs selection screen.
2. Scroll through the program options by pressing **PROGRAMS** or use the arrow keys. When USER PROGRAM PREVIEW is shown, press **ENTER**.
3. Press **ENTER** or wait 3 seconds. The screen displays PRESS START TO BEGIN OR EDIT TO SET UP.
4. Press **EDIT**. EDIT MODE requires a time for segment 1 (area in bold).

EDITING USER PROG 1	SEGMENT 1	SEGMENT 2
SPEED	3.0	SPEED 5.0
INCLINE	0	INCLINE 3
TIME	3:00	TIME 14:00

Use SWITCH FOCUS to toggle between Speed, Incline & Time.
Use Numeric Keypad or Speed/Incline + / - keys to enter new values.

Use PREVIOUS/NEXT keys below to change segments.
After desired final segment, set 0:00 as Time to END program.

Note: Press **SWITCH FOCUS** to toggle between speed, incline and time values for the current segment. To change segments, press **NEXT SEGMENT** or **PREVIOUS SEGMENT**. You can change segments in either the forward or reverse direction.

5. Use the numeric keypad to change the value and press **SWITCH FOCUS**. Continue to another segment by pressing the next or previous segment keys.
6. If you want a program to have less than 20 segments, create the last segment with 0 in the time field. The time reads END. The program ends when it reaches this segment.
7. When you finish editing your User-Defined Program, you can begin your program by pressing **START** or **DONE**.

Note: If you attempt to advance the cursor past the 20th segment, you are prompted with **PRESS START TO BEGIN OR EDIT TO SET UP**. You can also exit Edit Mode by pressing **MANUAL MODE** or **PROGRAMS** at any time.

3.5.1. Learn Mode

When you run a User-Defined Program and the speed or incline is adjusted, the treadmill saves the last change to the current segment.

Note: Learn Mode allows you to adjust existing segments in your user program, but you cannot add segments to it in Learn Mode.

1. Start a workout, then press **PROGRAMS** to display the Programs selection screen.
2. Scroll through the program options by pressing **PROGRAMS** or use the arrow keys. When the **USER PROGRAM PREVIEW** you desire is shown, press **ENTER**.
3. Press **START** to begin your program. When you begin, the Program Progress Detail screen is displayed. The speed and incline values of your current segment are displayed in the center. To change the speed or incline of your current segment, press the **SPEED (+/-)** or **INCLINE (+/-)** keys. The modified segment is stored with these new settings for the next time you run this program.

3.6. Specific Goal Programs

The Rehab treadmill provides Specific Goal programs. Whether you want to go for a 3-mile run or simply exercise for 15 minutes, the Goal Progress screen accurately assesses your progress with a variety of statistics. During these programs you retain full manual control.

1. Start a workout as outlined in “Using the Treadmill” on page 45.
2. Press **PROGRAMS** to display the Programs selection screen and select the goal program that you want to run:
 - For **TIME GOAL PROGRAM**, set a Program Time Goal using the numeric keypad or the arrow keys. Enter a time from 10 to 99 minutes, then press **ENTER** or wait 3 seconds.
 - For **DISTANCE GOAL PROGRAM**, set a Program Distance Goal using the numeric keypad or arrow keys. Enter a distance from 0.1 to 99.9 miles (km in metric), then press **ENTER** or wait 3 seconds.
3. Press **START** to begin.
The Goal Progress screen shows your Specific Goal (Time or Distance), counting down (noted by a negative sign).
4. Press **ENTER** at any time to view any of the other screens during your program.

3.7. Heart Rate Control Program

The Rehab treadmill offers a Heart Rate Control (HRC) program that displays your heart rate and automatically varies treadmill speed and elevation. HRC training allows you to maximize your workout performance while minimizing your workout time.

You must use the Pulse Grips or the optional Wireless Chest Strap to detect your heart rate during the HRC program.

HRC varies treadmill speed and elevation to keep your heart rate near the target heart rate for the entire workout.

Table 3-4 Heart Rate Control Program

Segment	Stage	% of Target Heart Rate	
		HRC	Interval HRC
1	Warm Up	70	70
2	Warm Up	80	80
3	Warm Up	90	90
4-18	Training	100	Alternating 80 & 100
19	Cool Down	90	90
20	Cool Down	80	80

3.7.1. Built-in HRC Program

1. Press **PROGRAMS** to display the Programs selection screen. Press **ENTER** while the HR Control program is displayed.
2. Select a program by using the arrow to scroll through the list, then press **ENTER**. You are prompted to enter the Maximum Speed: This scales the speed curve to the maximum speed entered.
3. Use the numeric keypad or arrow keys to select your maximum incline. Press **ENTER** or wait 3 seconds.
4. Use the numeric keypad or arrow keys to enter your target pulse. The treadmill will vary the speed and elevation in an effort to make you reach this heart rate. Press **ENTER** or wait 3 seconds.
5. The display prompts you to set a Program Time using the numeric keypad or center arrow. For HRC, enter a time between 20-99 minutes. This will scale the 20 segments of the program equally throughout your selected time. Press **ENTER** or wait 3 seconds.
6. Press **START** to begin.

4. Fitness Testing

4.1. Introduction

The Rehab treadmill has built-in tests that measure fitness level based on your age, gender, and performance.

A person's fitness level can be measured by the amount of oxygen their body can consume while exercising at maximum capacity. The maximum amount of oxygen (in milliliters) an individual can use in one minute per kilogram of body weight is referred to as VO_2 Max.

When you perform one of the fitness tests described in this section, the treadmill calculates approximate VO_2 Max and provides a fitness evaluation.

Note: Scores may vary due to line voltages, component tolerances, and individual capabilities. For a more accurate VO_2 Max calculation, take the average of the Balke and Firefighter Fitness Test scores.

4.2. Balke Fitness Test

Note: You must use the pulse grips or optional wireless chest strap for this test.

This is a walking pace, variable incline fitness test. The test increases in difficulty to raise your heart rate. Upon reaching your Target Heart Rate, the test ends and the treadmill calculates your fitness assessment. Parameters cannot be modified. Your age determines the test's target heart rate and the scaling of the fitness assessment.

Test Parameters:

- Maximum Speed: 4.4 mph
- Maximum Incline: 15%
- Maximum Heart Rate: 80% of Maximum Heart Rate (See Heart Rate Monitoring sections).

To run the test:

1. Press **PROGRAMS** to view the programs selection screen. To scroll through the programs, either continue to press **PROGRAMS** or use the arrow keys. Select the Balke Fitness Test by pressing **ENTER**.
2. Use the keypad or arrow to enter your age (10 to 99), then press **ENTER** or wait 3 seconds.
3. Enter your gender using the center arrow to toggle to MALE or FEMALE. Press **ENTER** or wait 3 seconds.

Note: The calculated target heart rate displayed before you start the test is derived from statistical heart rate capacity averages. (See “Heart Rate Monitoring” on page 13.) If you are uncomfortable with the target heart rate displayed or feel discomfort during the fitness test, stop the test.

Note: You must hold onto the pulse grips or wear the optional wireless chest strap for the entire test. If the treadmill loses the heart rate signal for more than 30 seconds the test is terminated.

4. Press **START** to begin the test.

This automated test increases in difficulty from segment to segment until you reach the target heart rate. When you reach the target heart rate a 30-second countdown follows and ends the test. Any key presses during the test (other than ENTER) will end the test.

When you begin, the Heart Rate Status screen shows your Target Pulse, Time, Heart Rate Status and Time in Zone.

Upon completion the treadmill displays your VO₂ Max score and fitness assessment based on your performance. Use the tables below to interpret your score based on your age and gender.

Table 4-1 Men: VO₂ Max

Age							Rating
<20	20-29	30-39	40-49	50-59	60-69	>69	
>65	>62	>58	>54	>52	>50	>48	Superior
57-65	54-62	50-58	46-54	44-52	42-50	40-48	Excellent
47-56	44-53	40-49	37-45	35-43	32-41	30-39	Good
37-46	35-43	32-39	28-36	26-34	24-31	22-29	Average
<37	<35	<32	<28	<26	<24	<22	Low

Table 4-2 Women: VO₂ Max

Age							Rating
<20	20-29	30-39	40-49	50-59	60-69	>69	
>62	>58	>54	>51	>47	>44	>42	Superior
54-62	50-58	46-54	43-51	39-47	36-44	34-42	Excellent
42-53	39-38	35-45	32-42	29-38	25-35	23-33	Good
34-41	32-38	29-34	25-31	22-28	19-24	15-22	Average
<34	<352	<29	<25	<22	<19	<15	Low

4.3. Firefighter (Gerkin) Fitness Test

This test requires the optional Wireless Chest Strap. It is a heart rate controlled, variable speed and incline fitness test. The test increases in difficulty to raise your heart rate. When you reach your target heart rate, the test ends and the treadmill calculates a fitness level based on your performance. Your age determines the test's target heart rate and the scaling of the fitness assessment.

Test Parameters

- Maximum Speed: 7 mph
- Maximum Incline: 15% (cannot be modified)
- Maximum Heart Rate: 85% of Maximum Heart Rate (See Heart Rate Monitoring sections).

To run the test:

1. Press **PROGRAMS** to view the programs screen.
2. Scroll through the programs using the arrow keys or by continuing to press **PROGRAMS**.
3. Press **ENTER** to select the Firefighter Fitness Test.
4. When prompted, use the keypad or arrow keys to enter your age (10 to 99), then press **ENTER** or wait 3 seconds.
5. Enter your gender by using the arrow keys to toggle between MALE and FEMALE. Press **ENTER** or wait 3 seconds.

Note: The calculated target heart rate is displayed before you start the test. This heart rate is derived from statistical heart rate capacity averages (see Heart Rate Monitoring Section) If you are uncomfortable with the target heart rate displayed or feel discomfort during the fitness test, stop the test.

6. Press **START** to begin.

Note: You must wear the optional wireless chest strap or hold onto the contact heart rate bars during the entire test. If the treadmill loses the heart rate signal for more than 30 seconds the test is terminated.

This test increases in difficulty until you reach the target heart rate, then a 30-second countdown follows and ends the test.

To stop the test at any time, press any key other than ENTER.

Upon completion the treadmill displays a VO_2 Max score and fitness assessment based on your performance compared to the general population.

Table 4-3 Firefighter Fitness Test Score

VO2 Max	Rating
>59	Superior
50-58	Excellent
40-49	Good
32-39	Average
<32	Low

5. Maintenance and Troubleshooting

5.1. Cleaning

It is recommended to clean the console and screen after each workout.

General: Vacuum around and under the treadmill at least once a month. Wipe any sweat from the treadmill after each workout.

Console and Display Screen: Wipe exposed console surfaces with a microfiber cloth, dampened with a mixture of 30 parts water to 1 part Simple Green® cleaner.
www.simplegreen.com

Wireless Chest Strap (Optional): The transmitter activates when the belt is moist. To conserve battery life, wipe the electrodes dry after each use. Clean monthly with mild soap and water and wipe dry.

CAUTION

To avoid damaging the electrodes, do not use abrasives to clean the chest strap. Do not bend or stretch the electrode strips, especially when storing the chest strap.

5.2. Maintenance

WARNING

Lethal voltages and moving parts capable of causing serious injury are exposed when the motor cover is removed. Under no circumstances should the motor cover be removed except by a Landice factory-authorized technician.

5.2.1. Lubrication

In institutional settings, Landice recommends lubricating the underside of the treadbelt with Landice SlipCoat every 3,000 miles. See instructions included with SlipCoat Lubricant.

5.2.2. Treadbelt Tracking Adjustment

Note: On the L7 model you should see an equal gap on either side of the treadbelt. On L8 models, a yellow warning label is visible on the deck from the rear of the treadmill when the treadbelt is not tracked correctly.

The treadbelt is tracked by means of the two 9/16" hex head bolts at the rear of the treadmill. Tightening (clockwise) the bolt on the side of the treadmill that the belt has moved towards and loosening the bolt on the opposite side an equal amount, will cause the belt to move toward the center. Adjustments should be made in ¼-turn increments, with the treadmill running at 2 to 3 mph. Allow at least 30 seconds for the belt to stabilize between each adjustment. To ensure proper belt tracking and alignment, the treadmill must be placed on a stable and level surface.

5.2.3. Treadbelt Tensioning

The treadbelt is tensioned at the factory but may require adjustment after installation. Need for tensioning is indicated by uneven belt speed and may be felt as sudden stopping of the treadbelt when your foot comes down on the belt.

To check belt tension: run treadmill at 1 mph, then walk on it. If the belt does not feel like it is slipping or hesitating, then the belt is tensioned correctly. If the belt slips/hesitates, then it is not fully tensioned.

The same hex head bolts used for tracking also tension the treadbelt. To tighten the treadbelt, turn both bolts clockwise exactly the same amount, ¼-turn at a time. Failure to turn them equally will affect belt tracking. **DO NOT OVER-TIGHTEN.** Continue checking for treadbelt slipping. When treadbelt is fully tensioned, speed up treadmill to 5 mph. Then, while jogging lightly, check for any sudden slipping/hesitating of the treadbelt. Repeat treadbelt tensioning if required.

5.2.4. Motor Drive Belt Tensioning



WARNING

Moving parts can cause serious injury. Always unplug treadmill before placing hands beneath the treadbelt!



CAUTION

DO NOT OVER-TIGHTEN. Over-tightening the motor drive belt can damage the drive motor and front roller.

Drive belt tension is preset at the factory. The belt is tensioned by a nut located under the motor pan. This nut is screwed to a hook attached to the motor bracket. Turning the nut clockwise tightens the nut, pulling down the motor bracket, which tightens the drive belt. To measure the tension, twist the drive belt between the motor and the drive roller. Ideal tension allows the drive belt to be easily twisted 45°. If you cannot twist the belt to at least 45°, it is too tight.

5.2.5. Service Checklist

- Tension and track treadbelt
- Lubricate belt and vacuum treadmill
- Check drive belt tension

5.3. Self-Diagnostics

This treadmill is equipped with on-board self-diagnostics. If the treadmill experiences any errors during operation, the treadmill will display the error message. You can run self-diagnostics to get further information on the error by pressing **ENTER**.



When you choose the option to enter diagnostics you will be prompted with a warning screen. After reading it, straddle the

treadmill by stepping on the traction strips on the sides of the running surface and press **ENTER**.

The treadmill will systematically test all of the individual components of the treadmill. During some of the tests, you will be prompted with simple “Yes or No” questions to assist with the diagnosis. Answer the questions when prompted.

When the Self-Diagnostics has completed all of the tests, it will read one of the two messages along the bottom: “No Errors Detected”, or “Error Detected, Contact Service Provider”. Contact your Dealer or go to www.landice.com and click on Service Locator to find a provider in your area.

To manually enter self-diagnostics mode, with the treadmill off, press the **3**, **9** and **START** at the same time.

5.4. Hidden Menu

The Hidden Menu provide access to control the settings listed below. To view the Hidden Menu press **3**, **9** and **START** at the same time while the control panel is off.

Use the **+** or **-** keys to move up and down the list. Then press the **START** button to select setting. Press **STOP** to save and exit the Hidden Menu section.

- **Error Logs:** Records the number of times a specific error code occurs.
- **NV Init - Boot:** Manufacturer's use ONLY
- **Diagnostics:** Provide technicians the ability to test buttons and calibrate. Press and hold **STOP** to exit diagnostic mode.
- **Reprogram Firmware:** Manufacturer's use ONLY
- **Self-Diagnostics:** Runs an automatic test of specific components to assist service technicians with diagnostics.
- **Toggle Programs:** Enables or disables access to programs through the Programs button on the control panel.
- **Toggle Incline Limits:** Enables or disables maximum incline limits at specific speeds.

- **Toggle Lockout Mode:** Enables or disables use of a code to operate the treadmill. When **Lockout Mode** is enabled it provides the ability to set a personalized four-digit code to use the treadmill. If the code is forgotten, 9010 will grant access.
- **Toggle Units:** Allows the measurement of units to switch between English and Metric.
- **Toggle Beeper:** Enables or disables the ability to control the beeping sound.
- **Toggle User Presence:** For International Use ONLY.
- **Toggle Client Mode:** Provides the ability to show two Clients and a guest on home screen. This feature is for residential use only.

LANDICE

111 Canfield Avenue, Suite A-1, Randolph, NJ 07869
1-800-LANDICE
Tel. 973-927-9010 · Fax 973-927-0630
www.landice.com