



OWNERS MANUAL

# FREE STANDING

WINE FRIDGE  
GC15S SERIES

# GRAND CRU®



@GrandCruWineFridges

[www.grandcruwinefridges.com.au](http://www.grandcruwinefridges.com.au)



NEED HELP? CALL

1300 935 683



# CONTENTS

---

<b>IMPORTANT SAFETY INFORMATION .....</b>	<b>4</b>
BEFORE USING THE APPLIANCE .....	4
FOR YOUR SAFETY .....	4
<b>STRUCTURE &amp; INSTALLATION .....</b>	<b>6</b>
ACCESSORY INSTALLATION BEFORE OPERATING .....	6
<b>OPERATING THE WINE FRIDGE .....</b>	<b>7</b>
WORKING CLIMATE .....	7
WINE STORAGE .....	7
RECOMMENDED TEMPERATURES .....	7
<b>CONTROL PANEL.....</b>	<b>8</b>
POWER ON/OFF CONTROL .....	8
TEMPERATURE SETTING .....	8
TEMPERATURE DISPLAY WINDOW .....	8
INTERIOR LIGHTING CONTROL .....	8
<b>CARE &amp; MAINTENANCE.....</b>	<b>9</b>
CLEANING THE WINE FRIDGE .....	9
POWER FAILURE.....	9
MOVING THE WINE FRIDGE .....	9
ENERGY SAVING TIPS.....	9
<b>TROUBLESHOOTING.....</b>	<b>10</b>
<b>WARRANTY, SERVICE AND SUPPORT .....</b>	<b>11</b>
WARRANTY REGISTRATION .....	11
SERVICE AND SUPPORT.....	11
<b>STORING AND STACKING .....</b>	<b>12</b>
DIFFERENT SHAPES & SIZES .....	12
STACKING FOR AGEING .....	12
STACKING FOR ACCESSIBILITY .....	12
<b>FREQUENTLY ASKED QUESTIONS.....</b>	<b>13</b>
<b>WINE STORAGE GUIDE .....</b>	<b>17</b>
<b>WINE TEMPERATURE SERVING GUIDE.....</b>	<b>19</b>

## IMPORTANT SAFETY INFORMATION

### FREE STANDING

WINE FRIDGE  
GC15S SERIES



This manual contains important information including safety and installation instructions of the appliances. Please read it carefully before use and follow all safety information and instructions. It is recommended to keep this manual for easy reference so that you can be familiar with the operation of the appliance.

### DO NOT TURN ON FOR AT LEAST 24 HOURS AFTER DELIVERY



Let the appliance stand upright for approximately 24 hours before connecting it to the power source, which helps to reduce the possibility of a cooling-system malfunction from handling during transportation.

#### BEFORE USING THE APPLIANCE

- Please remove all packaging, stickers and films from the products surface and clean the product's surfaces with a damp cloth and mild detergent before using for the first time.
- Let the appliance stand upright for approximately 24 hours before connecting it to the power source, which helps to reduce the possibility of a cooling-system malfunction from handling during transportation.
- Use a soft cloth to clean the interior surface with lukewarm water.

#### FOR YOUR SAFETY

Before using the appliance, please properly position and install it as described in this manual. To avoid the risk of fire, electrical shock, or injury when using the appliance, follow these basic precautions:

- This appliance is for domestic purposes only and is intended to be used exclusively for the storage of sealed bottled wines and beverages.
- The appliance must be positioned so that the plug is accessible.
- **Do not** connect or disconnect the electric plug with wet hands.
- To disconnect the appliance, grip the plug and pull it from the wall outlet. Never pull out by the cord.



- It is recommended that a separate circuit, serving only your appliance be provided.
- Unplug the appliance or disconnect power before cleaning, maintenance or servicing. Failure to do so can result in electrical shock or death.
- If the supply cord is damaged, it must be replaced by the manufacturer or its service agent or a similar order to avoid a hazard.
- The fuse (or circuit breaker) size should be **10 amps** or higher.
- This appliance can be used by children aged from 8 years and persons with reduced physical, sensory or mental capabilities or lack of experience and knowledge if they have been given supervision or instruction concerning use of the appliance in a safe way and understand the hazards involved. Children shall not play with the appliance. Cleaning and user maintenance shall not be made by children without supervision.
- This appliance is not intended for use by persons (including children) with reduced physical, sensory or mental capabilities, or lack of experience and knowledge, unless they have been given supervision or instruction concerning use of the appliance by a person responsible for their safety.
- Children should be supervised to ensure that they do not play with the appliance.
- To ensure proper ventilation for the appliance, the front of the unit must be completely unobstructed. Locate the unit away from direct sunlight and sources of heat (stove, heater, radiator, etc.).
- **Do not** attempt to repair or replace any part of the appliance unless it is specifically recommended in this manual. All other servicing should be referred to a qualified technician.
- Ensure enough peoples to move and install the appliance to avoid any damage to the appliance or injury to the peoples.
- It is important for the appliance to be leveled in order to work properly. You may adjust the appliance's feet to level it.
- Never clean the appliance parts with flammable fluids which may create a fire hazard or explosion. And do not store or use gasoline or other flammable vapors and liquids in the vicinity of the appliance.
- **Do not** use solvent-based cleaning agents of abrasives on the interior. These cleaners may damage or discolor the interior.
- **Do not** use this appliance for other than its intended purpose.
- **Do not** use electrical appliance inside the appliance.
- The use of attachments not recommended by the manufacturer may be hazardous.
- Please keep the products away from the fire or similar glowing substance before you dispose the appliance.
- GWP (Global Warming Potential): R600a
- When you dispose the appliance, take off the door and leave the shelves in place so that children may not easily climb inside. And make sure the coolant circuit, particularly the heat exchanger at the back/bottom of the unit is not be damaged.



The recycle symbol on the product or its packaging indicates that this product is not to be handled as normal household waste and it is to be taken to a recycling collection point for electrical and electronic goods.

## STRUCTURE & INSTALLATION

The following pictures only show description of appliance. The dimension and shelf quantity may differ among the models of the same series.

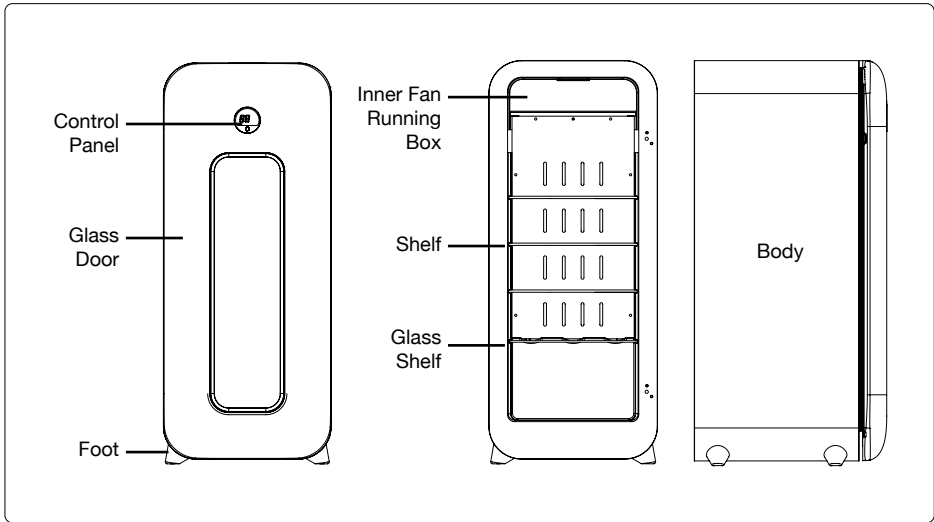

### ACCESSORY INSTALLATION BEFORE OPERATING

#### **DO NOT TURN ON FOR AT LEAST 24 HOURS AFTER DELIVERY**



Let the appliance stand upright for approximately 24 hours before connecting it to the power source, which helps to reduce the possibility of a cooling-system malfunction from handling during transportation.

### UNPACKING AND CLEANING THE WINE FRIDGE

- Remove the exterior and interior packing materials.
- Let the appliance stand upright for approximately 24 hours before connecting it to the power source, which helps to reduce the possibility of a cooling-system malfunction from handling during transportation.
- Use a soft cloth to clean the interior surface with lukewarm water.

# OPERATING THE WINE FRIDGE

## WORKING CLIMATE

- The appliance is designed for operating from SN to T climate (see below climate class chart). It is recommended to maintain the ambient around 22-25°C which helps the appliance working with low power consumption.

Climate Class	Ambient Temperature
SN = Subnormal	10°C -32°C (50°F-90°F)
N = Normal	16°C -32°C (61°F-90°F)
ST =Subtropical	18°C -38°C (64°F-100°F)
T = Tropical	18°C -43°C (64°F-109°F)

- If the ambient temperature is above or below the designed climate range, the performance of the unit may be affected. For example, the appliance operating in extreme cold or hot conditions may cause interior temperatures to fluctuate, and the temperature set 5-22°C may not be reached sometimes.

## WINE STORAGE

- The standard shelves are designed perfectly for Bordeaux style bottle storage. The maximum bottle loading may vary subject to the different size or dimension of wine bottles you store.
- The prevent damaging the door gasket, make sure to have the door opened fully all the way before pulling the shelves out.
- Do not cover the shelves with aluminum foil or any other shelf material which may prevent air circulation.
- Please store wine in sealed bottles.

- Should the wine fridge be left empty for long periods it is suggested that the appliance is unplugged, and after careful cleaning, leave the door ajar to allow air to circulate inside the cabinet in order to avoid possible condensation, mold or odors forming.
- Recommended temperatures for chilling/storing your wines.

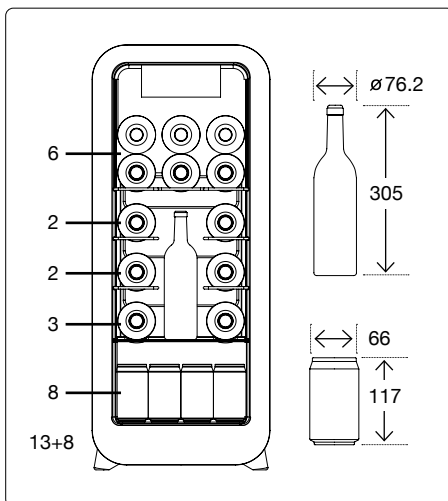

## RECOMMENDED TEMPERATURES

Wine Type	Recommended Temperature
Red	14-18°C (59°F-64°F)
White	6-14°C (48°F-57°F)
Rose	6-12°C (50°F-52°F)
Sparkling	4-10°C (41°F-46°F)

For further information see the "WINE TEMPERATURE SERVING GUIDE" on page 19.

---

## CONTROL PANEL

---

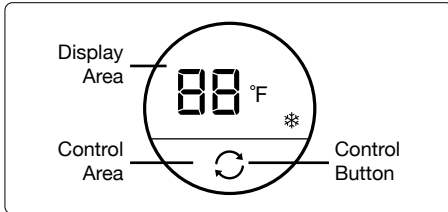

---

## POWER ON/OFF CONTROL

---

When the appliance is plugged in to a power outlet, it powers on automatically.



Warning: To avoid stressing the compressor, please do not turn on the appliance again within **5 minutes** after you turn it off.

---

## TEMPERATURE SETTING

---

- The temperature setting range is 2-22C.
- Touch the control button cycle to set the temperature as you want.
- The digital will change to display the setting temperature after 5 seconds without being touched.
- **Note:** For the first time to use the appliance or to restart the appliance after having been shut off for a long time, you may find a few degrees variance between the set temperature and the displayed temperature. It will be normal after a few hours running.

---

## TEMPERATURE DISPLAY WINDOW

---

- The temperature is displayed in digital which is the best way to be read out. The digital is shown as the set temperature when you are setting the temperature,
- When the temperature probe is out of order, the display window will show with "HH" or "LL" instead of a digital figure while continuous buzz sound will be heard. In case of this happens, this appliance is considerably designed to keep periodical running of compressor and fans which helps to keep the coldness of the inside cabinet to protect your stored wines.



Warning: To avoid destroying your stored wines, it is strongly recommended to have the appliance repaired immediately, as the periodical running cannot ensure the appliance will achieve the temperature you have set.

---

## INTERIOR LIGHTING CONTROL

---

- Touch the control button and hold for 3 seconds to turn on (or turn off) the interior LED lighting.
- The lighting will be continuously on if it is not turned off.



---

## CARE & MAINTENANCE

---

---

### CLEANING THE WINE FRIDGE

---

- Turn off the power, unplug the appliance, and remove all items including shelves.
- Wipe the inside surfaces with a sponge and baking soda solution. The solution should be about 2 tablespoons of baking soda to 1 litre of warm water.
- Wash the shelves with a mild detergent solution. Allow the wooden shelves to dry before placing them back into the wine fridge.
- Remove excess water from the sponge or cloth when cleaning the controls, or any other electrical display areas.
- Wipe the outside cabinet with warm water and a mild liquid detergent. Wipe dry with a clean soft cloth.
- Do not use steel wool or steel brush on the stainless steel. These will contaminate the stainless steel with steel particles and rusting may occur.

---

### POWER FAILURE

---

Most power failures are corrected within a few hours and should not affect the temperature of your appliance if you minimize the number of times the door is opened. If the power is going to be off for a longer period of time, you need to take the proper steps to protect your contents.

---

### MOVING THE WINE FRIDGE

---

- Remove all items.
- Securely tape down all loose items (shelves) inside your appliance.
- Turn the adjustable legs up to the base to avoid damage.
- Tape the door shut.
- Ensure the appliance stays secure in the upright position during transportation. Also protect the outside of appliance with a blanket, or similar item.

---

### ENERGY SAVING TIPS

---

- The appliance should be located away from heat producing appliances, and away from direct sunlight.
- Ensure that the unit is adequately ventilated. Never cover the air vents.
- Only open the door when necessary. Avoid leaving the door open for long periods or opening/closing the door frequently.

## TROUBLESHOOTING

If you feel the appliance is out of order, follow these instructions to try to see if you can solve the problem simply by yourself before calling for service.

Problem	Problem Possible Cause / Measure
The wine fridge does not operate	<ul style="list-style-type: none"> <li>• Not plugged in.</li> <li>• The appliance is turned off.</li> <li>• The circuit breaker tripped or a blown fuse.</li> </ul>
The wine fridge is not cold enough	<ul style="list-style-type: none"> <li>• Check the temperature control setting.</li> <li>• External environment may require a higher setting. The door is opened too frequently.</li> <li>• The door is not closed completely.</li> <li>• The door gasket does not seal properly.</li> </ul>
Automatically turn-on and turn-off frequently	<ul style="list-style-type: none"> <li>• The room temperature is hotter than normal.</li> <li>• A large amount of contents has been added to the wine fridge.</li> <li>• The door is opened too frequently.</li> <li>• The door is not closed completely.</li> <li>• The temperature control is not set correctly.</li> <li>• The door gasket does not seal properly.</li> </ul>
The lighting does not work	<ul style="list-style-type: none"> <li>• Not plugged in.</li> <li>• The circuit breaker tripped or a blown fuse.</li> <li>• The lighting is turned off.</li> </ul>
Too much vibration	<ul style="list-style-type: none"> <li>• Check to assure that the appliance is level.</li> <li>• Check to assure no parts inside the cabinet or in the compressor chamber are loose.</li> </ul>
The wine fridge seems to make too much noise	<ul style="list-style-type: none"> <li>• The rattling noise may come from the flow of the refrigerant, which is normal. As each cycle ends, you may hear gurgling sounds caused by the flow of refrigerant.</li> <li>• Contraction and expansion of the inside walls may cause popping and crackling noises.</li> <li>• The appliance is not level.</li> </ul>
The door will not close properly	<ul style="list-style-type: none"> <li>• The wine fridge is not level.</li> <li>• The gasket is dirty.</li> <li>• The shelves are out of position.</li> </ul>
The display window is shown with "HH" or "LL" instead of a digital figure, and/or with continuous buzz sound.	<ul style="list-style-type: none"> <li>• The temperature probe is out of order.</li> </ul>

---

## WARRANTY, SERVICE AND SUPPORT

---

Thank you for purchasing a Grand Cru Wine Fridge from Home Icon International Pty Ltd. Home Icon provides a 1-year warranty on this Grand Cru Wine Fridge.

---

### WARRANTY REGISTRATION

---

Register your wine/beverage fridge now for warranty, and allow us to provide you with the best possible after sales service:

1. Please log on to our website at **[www.grandcruwinefridges.com.au](http://www.grandcruwinefridges.com.au)**
2. Click on the **'Support'** tab across the top
3. Select **'Warranty Registration'** and fill out the details as required

This warranty does not cover the following:

- Any damages caused from improper use or not used in accordance with the instruction manuals.
- Damage caused by connecting your product to the wrong power source/supply.
- Incorrect installation or modifications made during installation or use of the product.
- Removing screws or otherwise opening the outer case will void the warranty.
- Any damages resulting from poor handling or moving of the product, misuse, fire or water damage etc.
- Failure to maintain the product as per the Instruction Manual.
- Problems caused by incorrect or inadequate venting of the product.

---

### SERVICE AND SUPPORT

---

Should an instance arrive where you require assistance, contact our support team:

1. Please log on to our website at **[www.grandcruwinefridges.com.au](http://www.grandcruwinefridges.com.au)**
2. Click on the **'Support'** tab across the top
3. Select the **'Request a Service'** option and fill out the details as required



NEED HELP? CALL  
**1300 935 683**

## STORING AND STACKING

---



---

### DIFFERENT SHAPES AND SIZES

This brochure makes reference to the 'standard Bordeaux style bottle' when specifying capacity. However, wine producers use a huge range of different bottle shapes and sizes. Bottle shape variety should be considered when selecting the appropriate Grand Cru cabinet in which to house your precious collection, since shelf height and adjustability varies across the product range. Please also be aware that some bottles will not fit opposite each other on the same shelf and this may affect capacity. You may need to lay the bottles opposite more suitably shaped bottles. Ideally, bottles should lie with their necks comfortably interlocking.

---

### STACKING FOR AGEING

When filling your cabinet, we suggest stacking the bottles you wish to cellar and mature at the back of the shelves, and the wines you wish to consume in the short term at the front.

## FREQUENTLY ASKED QUESTIONS



### **CHOOSING THE RIGHT WINE FRIDGE**

#### **To keep my wines ready to serve at the perfect drinking temperatures?**

Choose any Dual-Zone Grand Cru wine fridge, and keep in mind that most whites are generally best served at 6-8 deg C, and most reds at 16-18 deg C. With a Dual-Zone cabinet, you can fine-tune the serving temperatures of different styles of wine: You can set the temperature to suit your needs.

#### **To store my wines in the ideal cellaring conditions so they can mature?**

Choose any Grand Cru Wine fridge, and make sure you set it at 12-14 deg C as this is the proper temperature for cellaring and medium/long term storage for all wines: reds, whites, roses and champagne.

#### **To cellar only white wines or only red wines?**

All wines cellar at the same temperature (12-14 deg C), so any Single-Zone fridge set between 12-14 deg C is ideal for white wine and/or red wine storage. When set

within this temperature range, Single-Zone fridges will also keep humidity levels above 55% (which is important to maintain the integrity of the cork). Having said that, any dual zone can also be kept at the same temperature and humidity levels throughout the whole unit.

#### **To cellar both red and white wines?**

All wines — Whites, Reds, Champagnes — cellar at the same temperature (12-14 deg C), so any Grand Cru fridge set between 12-14 deg C is ideal for white wine and/or red wine storage. Set within this temperature range, Grand Cru wine fridges will also keep humidity levels above 55% (which is important to maintain the integrity of the cork).

#### **My wine is purely for investment: which wine fridge will suit me best?**

For (investment) wine to appreciate in value, the discerning purchaser will want a wine fridge that is designed for cellaring at the perfect temperature so any of the Grand Cru units will suit that purpose – it just becomes more of a question of the size of unit needed.

---

## **WINE TEMPERATURE**

---

### **At what temperature should I be cellaring my wines?**

The recommended cellaring temperature is between 12 and 14 degrees Celsius. Whichever temperature you choose, the key is to remember that the temperature must be constant.

### **What should the humidity levels be in my wine cabinet?**

The humidity in a wine cabinet should be over 55% so that corks don't dry out and shrink: humidity levels below 55% can lead to your wines spoiling because of oxidation. All Grand Cru wine fridges are designed to maintain humidity levels above 55% (when set at 12-14 deg C).

### **Do I need humidity control when cellaring my wines?**

YES, humidity is essential to ensure that the corks do not dry out. If that happens, they shrink and air can get into the wine. If air gets into the wine it will cause oxidation, generating an odorous smell.

### **How long can I keep my wines in a Dual -Zone wine fridge?**

As long as the temperature is correct, there is no limit to how long your wine can be stored in there.

### **Can I use my wine fridge for beer and food?**

No, wine fridges are not normal fridges. The temperature does not go low enough to keep food fresh and are not cold enough for the serving of beer. The Grand Cru GC46BC Beverage Centre is designed for beers (or white wines at drinking temperature), as they can cool beverages down to 2 deg C, and have metallic racks on which to stand beer bottles up. However, they are not suitable for food storage.

### **I have a Dual-Zone wine cabinet. Can I use one compartment for the serving of my white wines and the bottom compartment for cellaring my wines?**

YES. Just set the top compartment temperature to between 6\*-8\* and the bottom section to a temperature range of 12\*-14\*.

---

## **TECHNICAL & INSTALLATION**

---

### **What is the difference between Dual-Zone cabinets and Single-Zone wine cabinets?**

Dual -Zone wine fridges are designed for keeping and serving red and white wines at the perfect drinking temperatures. Single-Zone wine cabinets are designed for cellaring all wines (reds, whites or sparkling) at the proper temperature (12-14 deg C).

### **Does my cabinet require ventilation and can it be built-in under bench?**

Some of the Grand Cru range are not suitable for built -in installation, so please consider this before purchasing. The following Grand Cru wine fridges are suitable for built in installation: GC46, GC100, GC166, GC183 & GC194.

---

## **TROUBLE SHOOTING**

---

### **My unit is making a lot of noise**

If your wine fridge sounds noisy, it may be: 1) due to incorrect stacking of bottles and/ or the fridge is not completely level, so please empty the unit, check the levelling and then reload, 2) because ventilation requirements have not been considered, and so the unit is over-heating —refer to the manual or call Grand Cru for further help.

### **There is water coming out of the back of my cabinet.**

The door has been left open to some degree. Please wipe out the unit and ensure the door is shut.



**There is water on the inside back wall of my cabinet**

This is a perfectly normal occurrence and needed to maintain the correct humidity in the wine fridge. Just keep your bottles away from the wall so you do not block the water flow, an essential part of the cellaring climate.

**My bottles are wet**

If they are in contact with the back wall of the cabinet, they will have some condensation on them so please make sure you keep a finger's distance between the bottom of the bottle and the wall when you load. If not, please keep in mind that it is normal that condensation appears on the bottles after you open the door, and that high humidity is essential in cellaring your wine properly.

**There is a +/- 2 deg temperature swing on the digital readout**

Yes, this is normal. It is the variance in the air temperature that triggers the thermostat and the compressor. The small temperature fluctuations occur in the air around the bottles, not in the wine itself.

**There is condensation on the outer surface of the glass door of my wine cabinet**

This indicates excessive humidity in the environment.

**What happens if there is a power outage?**

The units are very well insulated and can maintain the temperature for hours before there is any change in the temperature itself. We don't advise opening the doors during the outage. Once the power is restored, electronically-controlled cabinets can revert to factory settings, so reset as necessary.

---

**SHIPPING & DELIVERY**

---

**What happens if my home/property is damaged?**

While this scenario is extremely rare, it can occur. If anything at your home/property is damaged by the carrier, contact Customer Support immediately! We will make the initial arraignments with the carrier to get compensation to you in a quick and timely fashion. As always, notate the BOL of what was damaged before you sign!

Note: Grand Cru cannot give direct compensation for damages that occur to your home/property before and/or after the fact. These actions have to be negotiated through you and the carrier, but as our customer we will give you all the necessary information and assistance needed to make sure you have a timely and satisfactory resolution to the matter.

**I signed for my wine cellar as delivered for in satisfactory condition, but I discovered damage later on. What do I do?**

If this occurs, please contact Customer Support immediately! There is a window of 48 hours where you would still be entitled to a replacement and/or compensation. After the window lapses, we cannot provide a replacement or compensation as the wine cellar is officially signed off "AS IS"

**I am receiving or I have received delivery and certain services are not being rendered or were not rendered. What do I do?**

Contact Customer Support so we can look into the matter directly with the carrier. We may be able to have the services rendered and/or provide compensation for the inconvenience. Note: Make sure you are informed of what services that are and are not included in your delivery. Refer to this information packet or you can discuss this at the time of purchase with your Home Icon Customer Representative before delivery.

**Does the carrier install/assemble any components (such as shelving) at the time of delivery?**

No. We cannot nor do we authorise the carrier to install shelving or assemble any part of the wine fridge. This is always the responsibility of the client regardless of what services are being rendered. If you require a white glove unpacking service, please contact Customer Support to find out more as this feature incurs a fee.

We hope that this has been informative and insightful information that will help you not only on your purchase, but as well as the delivery process. Should you have any further questions in regards to this information and/or should you have questions that are not included in this information packet please do not hesitate to contact us.

**Customer Support: 1300 935 683**

**Email: [info@homeicon.com.au](mailto:info@homeicon.com.au)**



**NEED HELP? CALL**

**1300 935 683**

## WINE STORAGE GUIDE



### SOME HELPFUL ADVICE

Have you bought some nice wine that you are planning keep for a special occasion or maybe you wish to start your own wine collection. What are the best tips for successfully storing your wine?

Firstly, it's useful to remember that only a small percentage of fine wines on the market benefit from long-term aging. Most wines are best enjoyed within a few years of release. If you're looking to buy wines to mature, you should really consider investing in a proper wine fridge or an external wine storage solution, but more about that later.

For everyone else, however, following a few simple guidelines should keep your wines safe until you're ready to drink them.

#### 1. KEEP IT COOL

Heat is enemy number one for wine. Temperatures higher than 21°C will age a wine more quickly than is usually desirable. And if it gets too much hotter, your wine may get "cooked," resulting in flat aromas and flavours. The ideal temperature range

is between 7°C and 18°C (and 14°C is often cited as close to perfect), though this isn't an exact science. Don't worry too much if your storage runs a couple degrees warmer, as long as you're opening the bottles within a few years from their release.

#### 2. BUT NOT COLD

Keeping wines in your household refrigerator is fine for a couple months, but it's not a good bet for the longer term. The average fridge temp sits between 3 - 4°C to safely store perishable foods, and the lack of moisture (humidity) could eventually dry out corks, which might allow air to seep into the bottles and damage the wine. Keeping wine in a fridge for a longer time will also slow down the aging process which is not ideal.

#### 3. CONSISTENCY IS THE KEY

More important than worrying about achieving a perfect 12°C is avoiding the landmines of rapid, extreme or frequent temperature variations. Temperature variation is likely to be more critical for older wines where the seal of the cork is less tight (corks lose some elasticity

with age). The problem with temperature variations is that the volume of the wine expands as temperature rises, decreasing the ullage volume, and then contracts as temperature falls, increasing the ullage volume. If the closure is providing a completely airtight seal then this is of relatively little consequence. Aim for consistency, but don't get paranoid about minor temperature fluctuations; wines may see worse in transit from the winery to the store. (Even if heat has caused wine to seep out past the cork, that doesn't always mean the wine is ruined. There's no way to know until you open it—it could still be superb).

#### **4. TURN OFF THE LIGHTS**

Light, especially sunlight, can pose a potential problem for long-term storage. The sun's UV rays can degrade and prematurely age wine. One of the reasons why vintners use coloured glass bottles? They're like sunglasses for wine. Light from household bulbs probably won't damage the wine itself, but can fade your labels in the long run.

#### **5. HUMIDITY IS IMPORTANT BUT NOT CRITICAL**

Conventional wisdom says that wines should be stored at an ideal humidity level of 70 percent. The theory goes that dry air will dry out the corks, which would let air into the bottle and spoil the wine. Yes, this does happen, but unless you live in a very dry desert or arctic like climate, it probably won't happen to you. Anywhere between 50 percent and 80 percent humidity is considered safe, and placing a tray or saucepan of water in your storage area can improve conditions. Conversely, extremely damp conditions can promote mould. This won't affect a properly sealed wine, but can damage the labels. A dehumidifier can fix that.

#### **6. FLAT OR STANDING – STORING OR ON SHOW**

Traditionally, bottles have been stored on their sides in order to keep the liquid up against the cork, which theoretically should keep the cork from drying out. If you're planning on drinking these bottles in the near-term, or if the bottles have alternative closures (screw caps or synthetic corks), this is not necessary.

#### **7. LIMIT THE MOVEMENT**

There are theories that vibration could damage wine in the long term by speeding up the chemical reactions in the liquid. Some serious collectors worry about even the subtle vibrations caused by electronic and other appliances, though there's little evidence supporting the impacts of this. Significant vibrations could possibly disturb the sediment in older wines and keep them from settling, potentially making them unpleasantly gritty.

---

#### **WHERE SHOULD I STORE MY WINE?**

---

If you do not have a cool, not-too-damp basement or underground garage that can double as a fridge, you can improvise with some simple wine racks in a safe place. Rule out your kitchen or laundry, where hot temperatures could affect your wines, and look for a location that is generally less effected by climate control systems and not directly in line with sun light pouring in from a window. Perhaps there is a little-used closet or other vacant storage area that could be repurposed for storing wine?

## WINE TEMPERATURE SERVING GUIDE



### HOW TO SERVE WINE

When it comes to serving your favourite bottle of wine at the correct temperature, ideally it should be just right. Too hot and the wine's alcohol will be emphasized, leaving it flat and flabby. Too cold and the aromas and flavours will be muted and, for reds, the tannins may seem harsh and astringent. The old adage of serving white wines chilled and red wines at room temperature is a useful starting point, although not nearly detailed enough.

The reason we try to serve wine at their correct temperatures is because the temperature can dramatically impact the way a wine smells and tastes. By serving the wine at its ideal temperature, we ensure we will always get the best experience and enjoyment from our favourite bottle.

For those like myself who wish to be even more specific, I have included below some more detailed serving temperature recommendations for Australia's most popular wine varietals.

### NON-VINTAGE CHAMPAGNE/SPARKING WINE AND ICE WINE – ICE COLD, 4-6°

I like to put my bubbly in the freezer about an hour before I pop it – but don't forget about it or you'll have an explosion. If you're short on time, you can also place the bottle in an ice bucket for 30 minutes and have similar results. The ice cold temperature will keep the bubbles fine rather than foamy. After you open the bottle and pour the first glasses, you should place the open bottle on ice until the entire bottle is finished.

### LIGHTER BODIED WHITE WINE, SWEETER ROSÉ, VINTAGE CHAMPAGNE AND DESSERT – COLD, 6-10°

The best way to get lighter bodied white wine and sweeter rose cold is to place it in the fridge immediately after buying it; however, if you buy the wine already chilled the same day you want to drink it, either leave it in the fridge for several hours, or you can place it in the freezer for about 30 minutes. After you open the bottle and pour the first glasses, you should place the open bottle on ice until the entire bottle is finished.

**FULL BODIED WHITE WINE AND DRY ROSÉ – COOL, 10-14°**

The best way to get full bodied white wine cool is to place it in the fridge or preferably a wine fridge immediately after buying it. I suggest taking the wine out of the fridge 30 minutes prior to serving and after opening the bottle and pouring everyone their first glass, I prefer not to place it on ice, but instead let the bottle sweat on the table, as the wine's aromas and character changes slightly as the temperature rises.

**LIGHTER BODIED RED WINE – COOLED, 12-16°**

The most common misconception with lighter bodied red wine is that it is ideal to serve it at room temperature (see below), when in fact serving it cool is the best way to enjoy it. To cool lighter red down to its proper serving temperature, either place it in the fridge an hour before serving or preferably invest in a good quality wine fridge and serve immediately at the right temperature. After opening and either decanting or pouring the first glasses, just as with full bodied white I like leaving the wine out on the table to slowly warm.

**FULL BODIED RED WINE – ROOM TEMPERATURE, 16-18°**

Depending on the time of year, room temperature in Australia sits somewhere between 20°C and 25°C which is not the ideal serving temperature. Red wine served too warm will lose all its finesse and freshness to an overpowering sensation of alcohol. To cool full bodied red down to its ideal serving temperature, I like to place it in the fridge 20 minutes before serving or preferably invest in a good quality wine fridge and just take it out 15 minutes prior to serving. After opening and either decanting or pouring the first glasses, leave the wine out on the table.

**POCKET GUIDE**

---

**19° VINTAGE PORT**

---

**16° - 18° SHIRAZ, DURIF, CABERNET SAUVIGNON**

---

**14° - 16° PINOT NOIR, GSM, SANGIOVESE CABERNET MERLOT, GRENACHE, TAWNY PORT**

---

**12° - 14° CHARDONANAY, MERLOT, GAMAY**

---

**10° - 12° DRY ROSE, SEMILLON, VIOGNIER, MARSANNE, SAUTERNES**

---

**8° - 10° SPARKLING RED, CHENIN BLANC, REISLING, VERDELHO, SEMILLON SAUVIGNON BLANC, VINTAGE CHAMPAGNE**

---

**6° - 8° SAUVIGNON BLANC, SWEET ROSE, PINOT GRIGIO, PINOT GRIS, DESSERT WINES**

---

**4° - 6° NON-VINTAGE CHAMPAGNE, SPARKLING WHITE, ICE WINES**

---





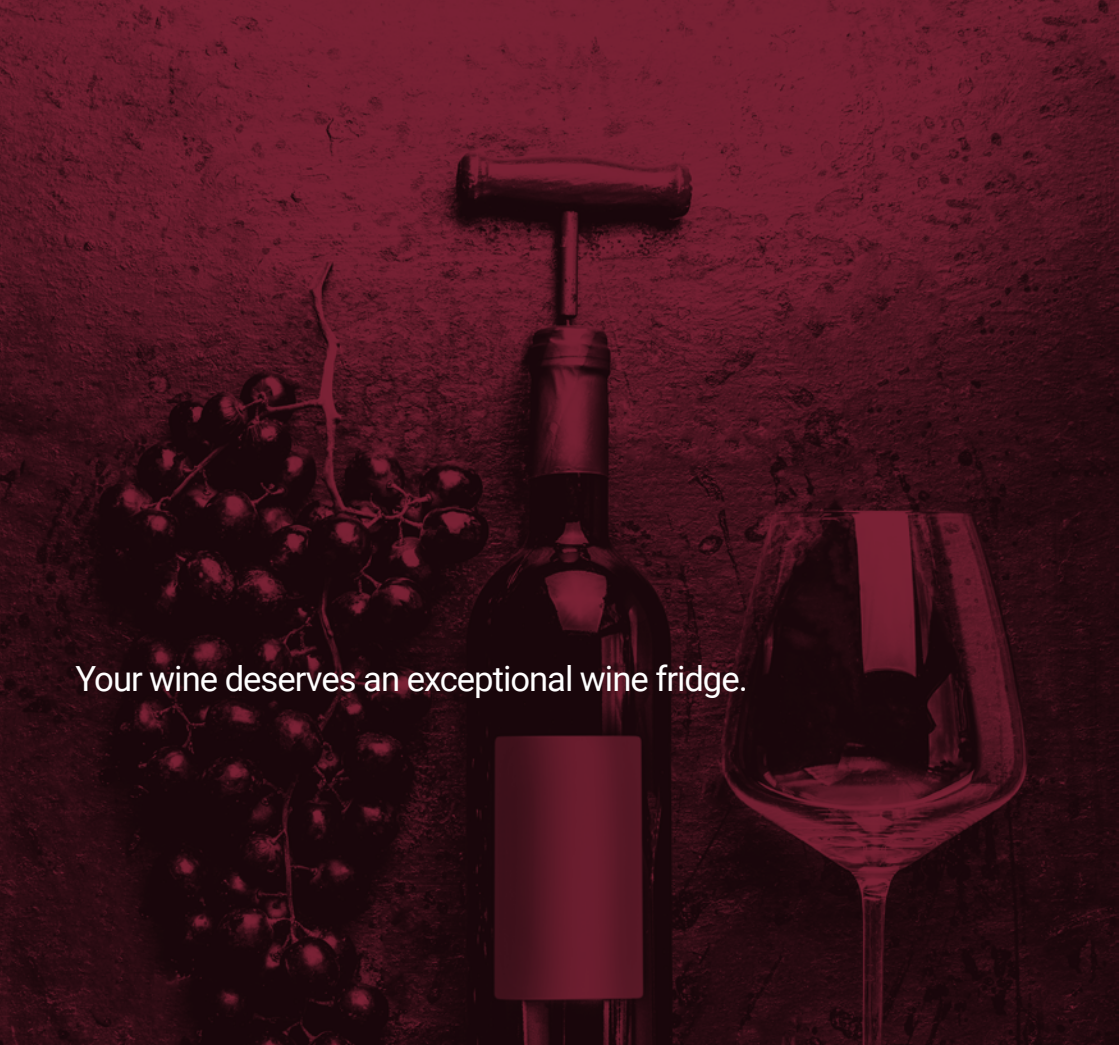

Your wine deserves an exceptional wine fridge.

**GRAND CRU**®



@GrandCruWineFridges

[www.grandcruwinefridges.com.au](http://www.grandcruwinefridges.com.au)



NEED HELP? CALL  
1300 935 683