



FUEL TANK
REFUELLING SOLUTIONS

Technical Guide

V1.0





Table of Contents:

iFUEL® Tank technical and unit installation details:

1. Introduction

2. iFUEL® TANK Hardware

2.1 Overview

2.2 Hardware Setup

2.2.1 Power (CON3)

2.2.2 SIM Card (CON2)

2.2.3 GSM Antenna (CON6)

2.2.4 GPS Antenna (CON8)

2.2.5 Tank Gauge Connections (CON10-13)

2.2.6 Start-up, LED Indicators And Buzzer

3. Specifications

iFUEL® TANK Website and Configuration Guide:

1. iFUEL® TANK Login

2. iFUEL® TANK Website

2.1 Cog-Menu

2.2 Add Site

2.2.1 Customer Details

2.2.2 Site Details

2.3 Tank Configuration - 8 tank upgrade

2.4 Tank Configuration - Enabling a tank

2.5 Tank Configuration - Device specific configuration

2.6 Device configuration



iFUEL® TANK

Technical and Unit Installation Details

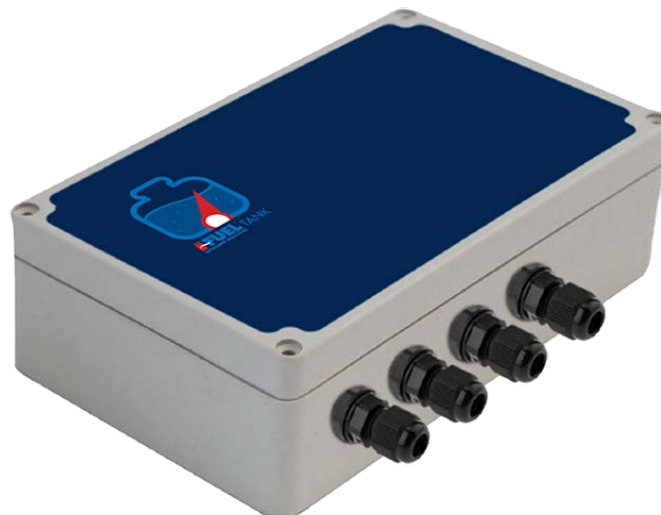
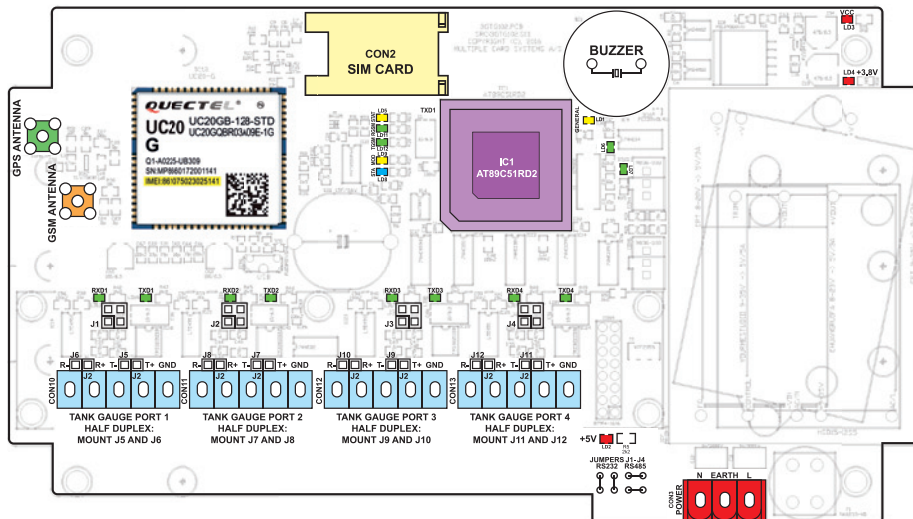



1. Introduction

The purpose of iFUEL® TANK is to read the content of the fuel in a fuel tank, as well as other parameters, like temperature, alarms, location, etc. The data is then transmitted through mobile data via the Internet to a web server, which in turn presents the data for the customer on a website.

The tank gauges / protocols supported so far are as follows:

- Ocio
- OLE / MODBUS
- Veeder-Root / Gilbarco / Franklin

2. iFUEL® TANK Hardware

2.1 Overview

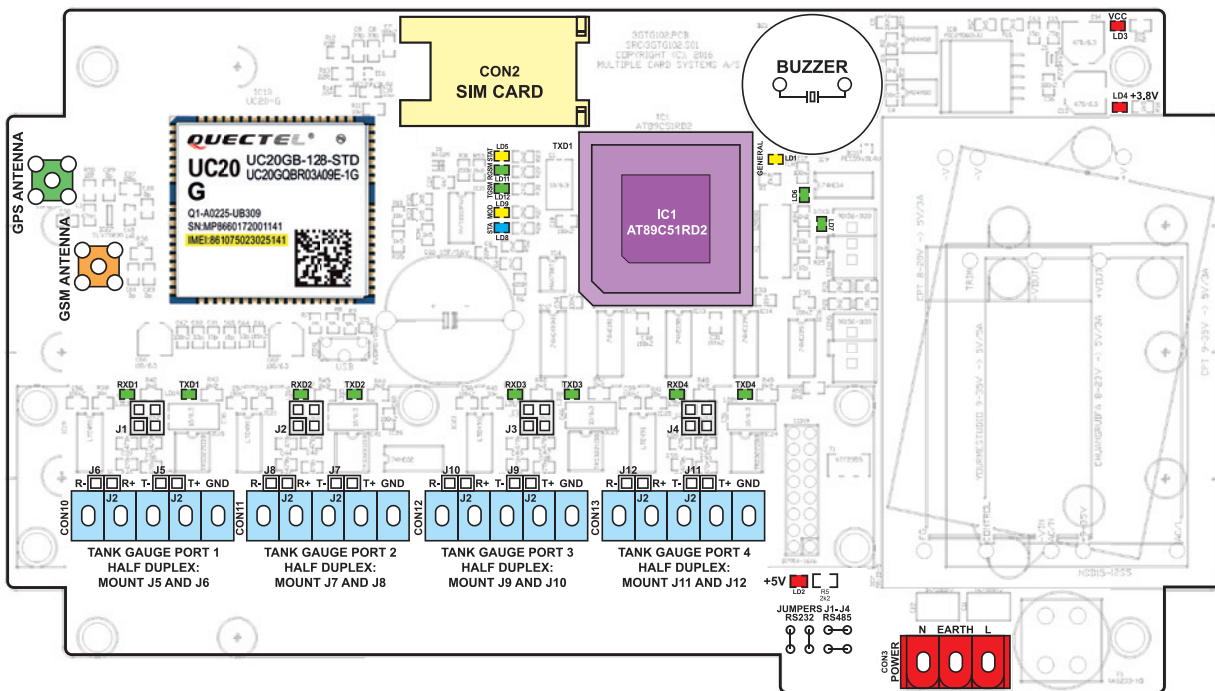

The above figure shows the main components of the iFUEL TANK. On the right-hand side of the board is the power supply, which runs on anything from 90 to 260 VAC. At the bottom mid and left-hand side are interface connections. Each consists of an RS232/485 interface port, making it possible to communicate with 4 tank gauges or tank gauge monitors simultaneously. In the mid-top section of the board are found the microcontroller AT89C51RD2 and a buzzer, which together with a number of LEDs provide feedback to the user as to the state of the device. In the upper-left-hand corner is found the GSM chip UC20G, the SIM card socket and antenna connections, which provide access to the Internet via mobile data.

Note 1: If a group of tank gauges has the same RS485 half-duplex interface, those gauges could potentially be wired together and be read by only one interface port on the device.

Note 2: No power is provided to the tank gauges by the device.



2.2 Hardware Setup

2.2.1 Power (CON3)

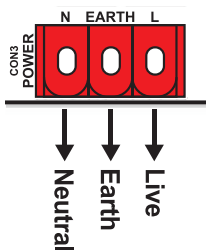

Connect anything from 90 to 260 VAC to Neutral (N) and Live (L). Remember to connect EARTH to the power outlet as well for safety reasons. Don't turn on power before the hardware setup has been completed.

2.2.2 SIM Card (CON2)

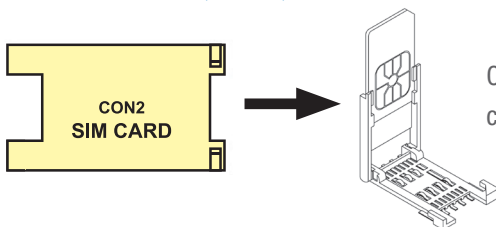

Open the SIM card connector, insert a full-size SIM card, close the connector. The SIM card can only go in one way.

2.2.3 GSM Antenna (CON6)



The iFUEL® TANK comes with a passive internal GSM antenna (SMA connector) on CON6. However, if the device is mounted inside a metal enclosure, it might be hard to obtain good reception. In such cases, connect an external GSM antenna, run the cable through one of the glands at the bottom of the casing, and make sure the antenna itself is located as high as possible to ensure good mobile reception.

2.2.4 GPS Antenna (CON8)

The iFUEL® TANK comes with an active internal GPS antenna (SMA connector) on CON8. However, the same principle as for the GSM antenna applies. If the device is mounted where good reception from the GPS satellites is hard to obtain, use an active external GPS antenna. Connect it to CON8, run the cable through one of the glands at the bottom of the casing, and make sure the antenna itself is located with free space above it for good satellite reception.

2.2.5 Tank Gauge Connections (CON10-13)

All the 4 tank gauge connection circuits are identical. In the following, port 1 (CON10) is used as an example. The port consists of a combined RS232/RS485 interface. The RS485 interface can be setup as 2-wire or 4-wire communication (half-duplex or full-duplex).

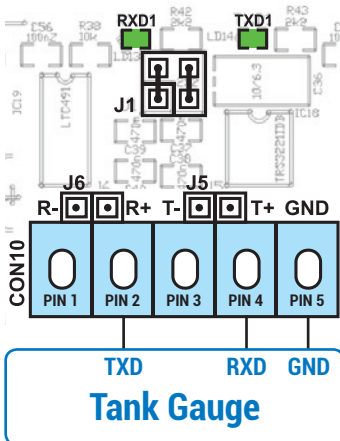

RS232 Connections:

Mount two jumpers on J1 vertically.

The following table shows how to connect the tank gauge:

Cloud Gauge Signal	Cloud Gauge Port Pin	Tank Gauge Signal
Receiver	Pin 2, R+	TXD
Transmitter	Pin 4, T+	RXD
Ground	Pin 5, GND	GND

RS232 is used by the Franklin tank gauge monitor, running the Veeder-Root / Gilbarco protocol.

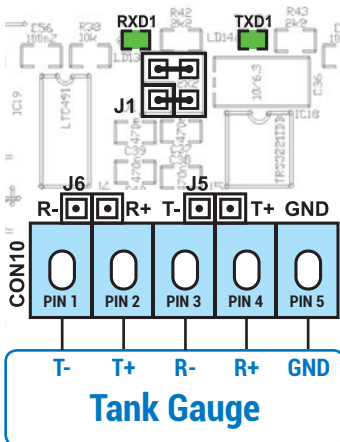

RS485 4-Wire Connections:

Mount two jumpers on J1 horizontally.

The following table shows how to connect the tank gauge:

Cloud Gauge Signal	Cloud Gauge Port Pin	Tank Gauge Signal
Receiver, minus	Pin 1, R-	T-
Receiver, plus	Pin 2, R+	T+
Transmitter, minus	Pin 3, T-	R-
Transmitter, plus	Pin 4, T+	R+
Ground	Pin 5, GND	GND

Note: Ground might not always be available on the tank gauge; connect if available.

The Ocio tank gauge uses this configuration, although only pin 1 and 2 are connected.

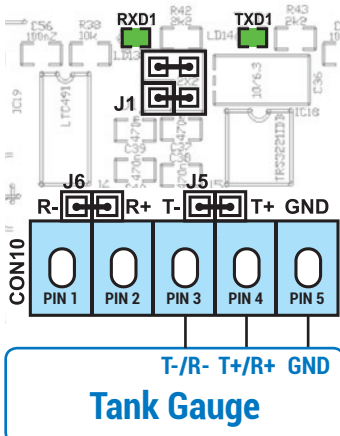

RS485 2-wire Connections:

Mount two jumpers on J1 horizontally.

Mount a jumper on J5 and J6.

The following table shows how to connect the tank gauge:

Cloud Gauge Signal	Cloud Gauge Port Pin	Tank Gauge Signal
Transmitter, minus	Pin 3, T-	T-/R-
Transmitter, plus	Pin 4, T+	T+/R+
Ground	Pin 5, GND	GND

Note: Ground might not always be available on the tank gauge; connect it if it is.

The OLE / MODBUS tank gauge uses this configuration.



2.2.6 Start-up, LED Indicators And Buzzer

When the iFUEL® TANK is turned on, the following happens:

1. The buzzer plays the start-up melody.
2. LD1 flashes quickly for approx. 7 seconds, while the program's checksum is verified.
3. The buzzer beeps.
4. LD1 flashes slowly a few times.
5. The buzzer plays the GSM-melody to indicate that communication with UC20C is established.
6. LD8 (blue) flashes: 80/20% = Network searching, 20/80% = Network ready, 50/50% = Transmitting.
7. LD1 shows the signal strength: 0-5 flashes = 0-100% signal strength.
8. LD13-20 indicate communication with the tank gauges.

Whenever an SMS setup is received, the buzzer plays the SMS melody. This is followed by an un-scheduled transfer of data to the web host.

The following table shows all the LEDs and their functions:

LED	Colour	Function
LD1	Yellow	General indicator. Shows signal strength when idle: 0-5 flashes = 0-100% signal strength
LD2	Red	+5V to the port interfaces
LD3	Red	VCC (+5V) to the microcontroller
LD4	Red	+3.8V to the UC20G GSM chip
LD5	Yellow	UC20G status
LD6	Green	UC20G debug receiver, CON4
LD7	Green	UC20G debug transmitter, CON4
LD8	Blue	UC20G network indicator: 80/20% = Searching, 20/80% = Ready, 50/50% = Transmitting
LD9	Yellow	UC20G network mode indicator
LD11	Green	US20G transmitter for controller
LD12	Green	US20G receiver for controller
LD13	Green	Port 1 receiver
LD14	Green	Port 1 transmitter
LD15	Green	Port 2 receiver
LD16	Green	Port 2 transmitter
LD17	Green	Port 3 receiver
LD18	Green	Port 3 transmitter
LD19	Green	Port 4 receiver
LD20	Green	Port 4 transmitter



3. Specifications

Item	Value	Comments
Device Power	90 - 260 VAC, max 350mA, typical 20mA	Power for the device
Fuse	1A slow	
GPS Antenna	3V, max 100mA	Power for the active GPS antenna
Operating Temperature	-40 - +55°C	
Storage Temperature	-40 - +85°C	
SIM card	Full size	
GSM Antenna	SMA connector	
GPS Antenna	SMA connector	
UMTS Frequency Bands	800/850/900/1900/2100 MHz	
GSM Frequency Bands	850/900/1800/1900 MHz	
Data transfer	HSPA+, UMTS, EDGE, GPRS, CSD	
Tank Gauge Support	Ocio OLE / MODBUS TLS2 / Veeder-Root / Gilbarco	RS485, one way ASCII T4020 and others TLS2, TLS300, TLS350 and others



iFUEL® TANK Website and Configuration Guide:





1. iFUEL® TANK Login

The URL for the iFUEL® TANK website is:

www.ifuelcloud.com.au

In case a user forgets the password, it is also possible to click the “Forgot password?” link, which will send an email to the users with instructions on how to reset the password.

The screenshot shows a login form with the following elements:

- Title: Please Sign In
- Input field: Username
- Input field: Password
- Button: Sign in
- Link: Forgot password ?

2. iFUEL® TANK Website

2.1 Cog-Menu

Once logged in, in the upper right corner, a cog-wheel is shown. This makes it possible to

- Manage Users (Visible when a customer is selected)
- Add sites
- Change Password

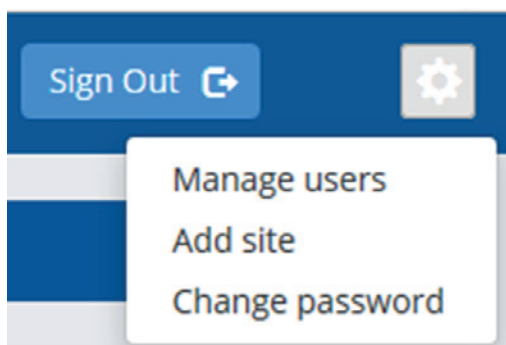



2.2 Add Site

2.2.1 Customer Details

When adding a site, various sections must be filled out.

Here it is possible to either choose an existing customer or create a new customer.

Customer Details

Choose an existing customer from the list or enter a name to create a new customer *

Choose an existing customer

Or create a new customer

2.2.2 Site Details

This section covers the details for this site specifically. The fields marked with an asterisk are mandatory fields.

Site Details

Site Name * **Site Number ***

Address

Contact Name **Phone Number**

Fuel Supplier Name



2.3 Tank Configuration - 8 tank upgrade

The next tick box allows you to add an 8 tank upgrade. This will make it possible to set up 8 tanks on the site. Once ticked, the number of tanks you can enable goes from 4 to 8.

Tank Configuration

Please enable and configure at least one tank.

Add 8 tank upgrade



2.4 Tank Configuration - Enabling a tank

Once a tank is ticked as enabled, the fields can be edited. On the top a series of general settings are available, including a help text.

<input checked="" type="checkbox"/> Enable Tank
Description <input type="text"/> Name or Identifier (e.g. McDonalds Diesel tank)
Port Number * <input type="text" value="1"/> Device Port Number
Delivery Start Trigger * <input type="text" value="50"/> Liters per Minute that triggers a Delivery Start
Delivery Stop Trigger * <input type="text" value="5"/> Liters per Minute that triggers a Delivery Stop
Fuel Drop Level * <input type="text" value="0"/> If fuel drops more than this within the communication interval, device sends an update
Liquid / Fuel Type * <input type="text"/> e.g. Diesel, Petrol
Capacity * <input type="text"/> Tank capacity in litres



2.5 Tank Configuration - Device specific configuration

For each tank set up, once the Gauge Type is chose, a series of device specific settings are available, which must be set to match how the tank gauge is set up.

Gauge Type *
<input type="text" value="TLS2"/>
Gauge ID *
<input type="text"/>
Address *
<input type="text"/>
Enter a number 1 to 99
Comport *
<input type="text"/>
Enter comport
Security Code *
<input type="text"/>
Enter security code



2.6 Device configuration

Under Device Configuration, choose a pending device, and proceed with the setup for the SIM card and finally select how often the device shall send in updates (Communication Interval). The information required to set up the SIM card can be obtained from the Internet Service Provider.

Device Configuration

Choose a pending device *

Phone/Cell Number *

Please select the international dialling code enter the device's SMS number, e.g. +44 7779123456

APN *	Username	Password
<input type="text"/>	<input type="text"/>	<input type="text"/>
Access Point Name, from Internet Provider	AP-Username - if needed	AP-Password - if needed

Auth Protocol *

AP-Auth Protocol - if needed

Communication Interval *

How often data is sent in