

DO NOT SCALE FROM DRAWING. IF IN DOUBT: ASK

UNLESS OTHERWISE SPECIFIED, ALL DIMENSIONS ARE IN MILLIMETRES

BEWARE OF 100mm MEASURING ERROR

TANK DATA	
TANK CONTENTS:	DIESEL/AdBlue
DESIGNED TO:	AS1940
BUILT TO:	AS1692,CAT.3
CORROSION ALLOW:	0mm
GROSS VOLUME:	73,308L/7,310L
HYD.TEST PRESSURE:	Gross level+150mm
SAFE FILL LEVEL:	69,308L/6,945L
N.D.T	
TOTAL MASS:	16,648KG

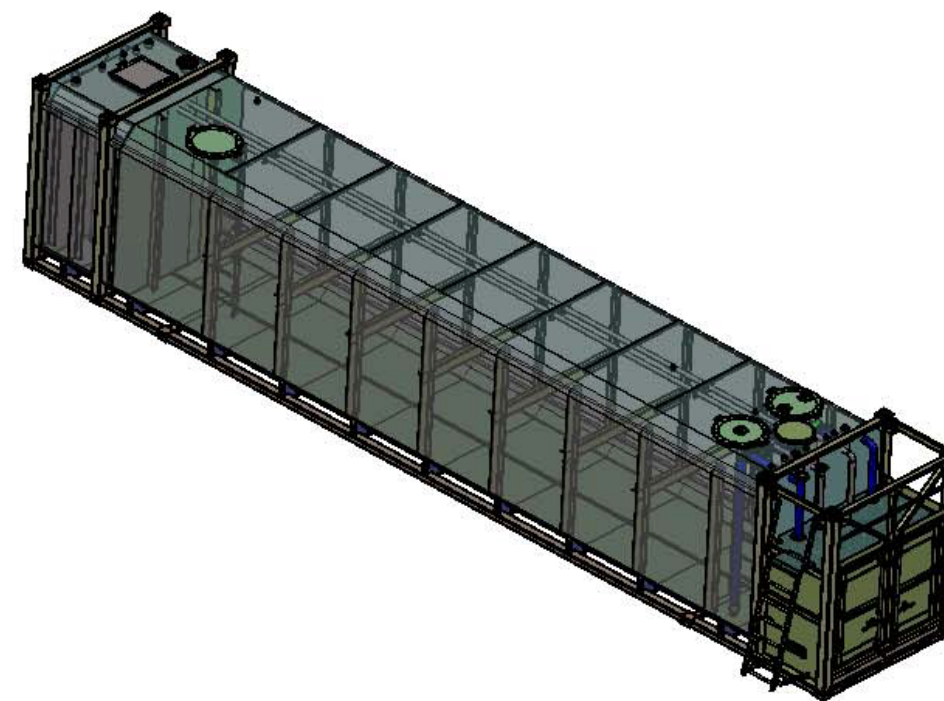
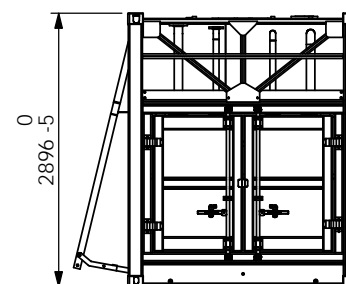
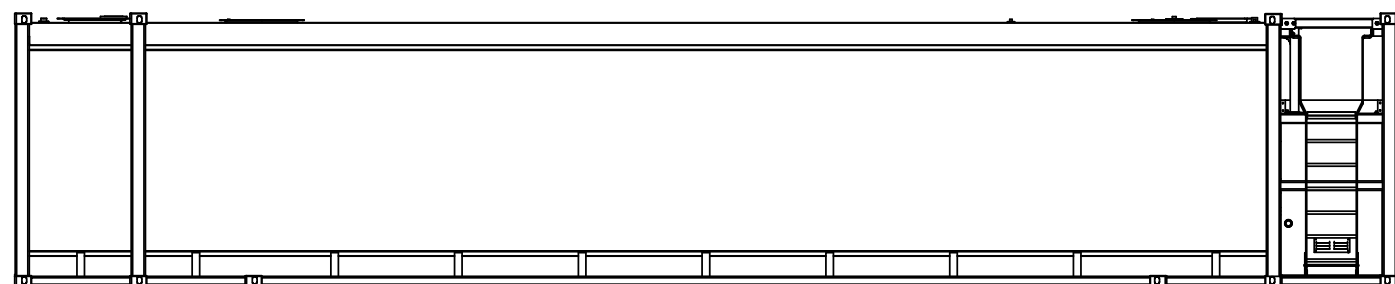
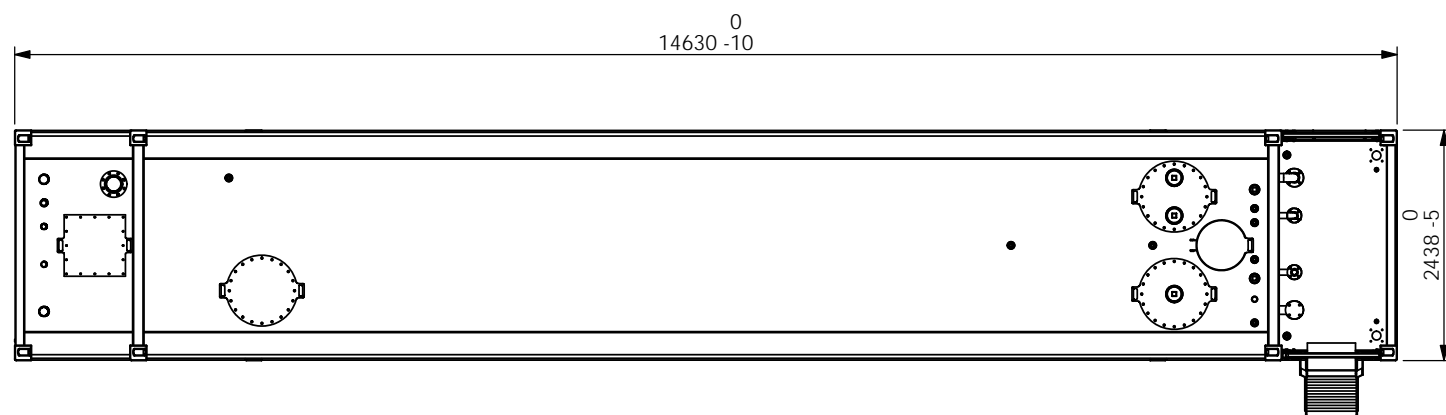

THIRD ANGLE PROJECTION	
○	
NAME	DATE
DRAWN	2016/6/23
CHK'D	
APP'VD	

**FUEL**  
REFUELLING SOLUTIONS

TOLERANCE U.N.O:  
0 = -1.0  
0.0 = -0.4  
0.00 = -0.1

MATERIAL:  
WEIGHT: 16536.65 Kg

DWG NO. / PART NO.		JOB NO.	
CLIENT: 80,000L iFUEL CONAB SELF BUNDED TANK			
TITLE:			SHEET SIZE <b>A3</b>
SCALE: N.T.S.		SHEET 1 OF 2	
			REVISION <b>01</b>

DO NOT SCALE FROM DRAWING. IF IN DOUBT: ASK

UNLESS OTHERWISE SPECIFIED, ALL DIMENSIONS ARE IN MILLIMETRES

BEWARE OF 100mm MEASURING ERROR

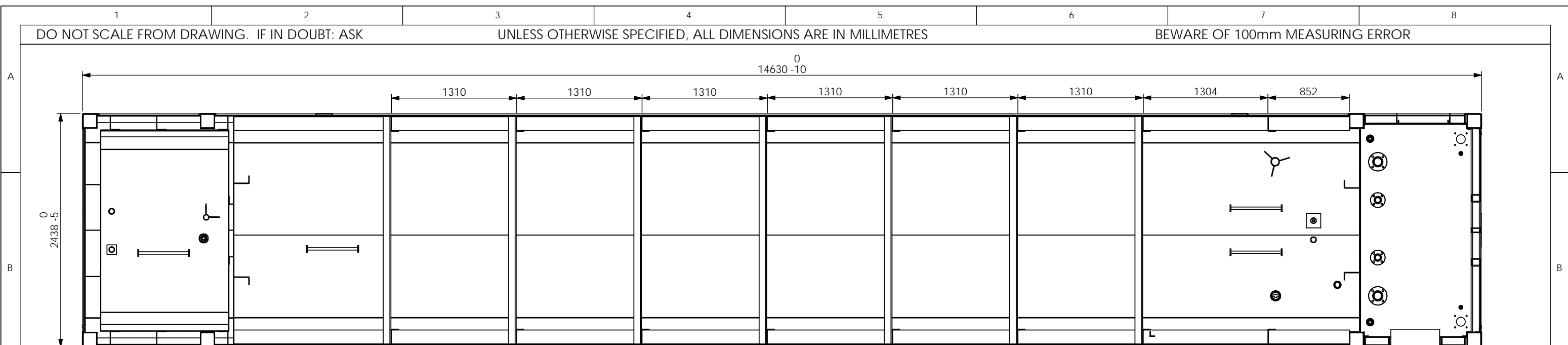

剖面 B-B

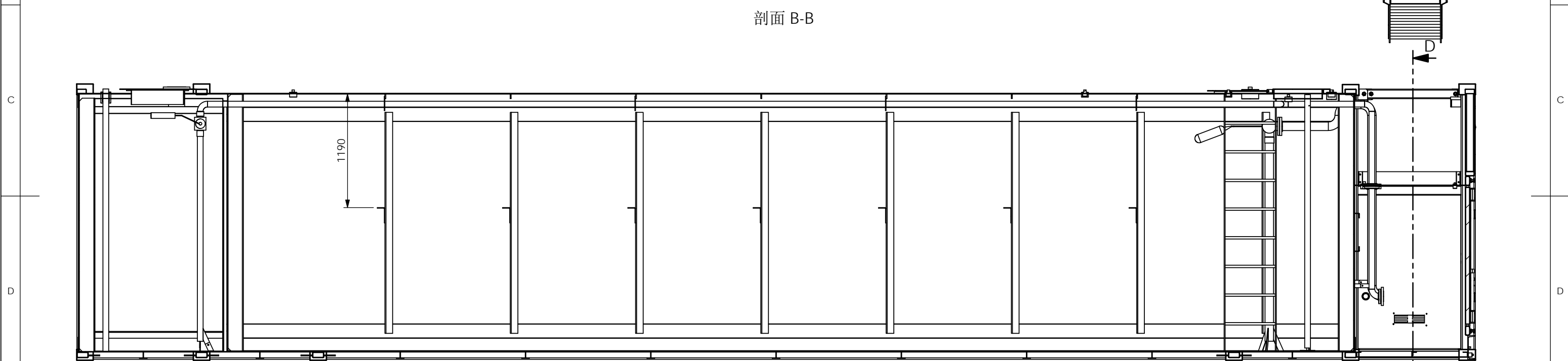

剖面 C-C

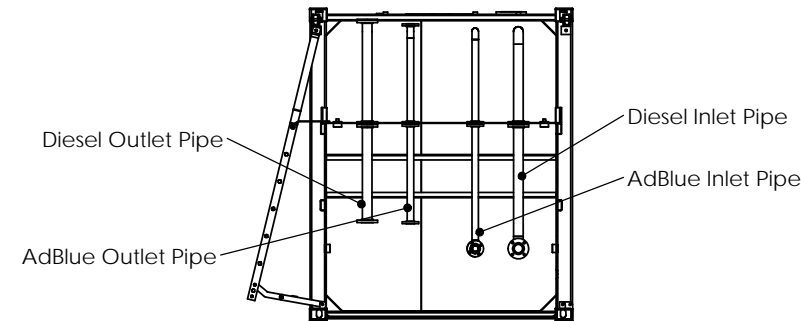
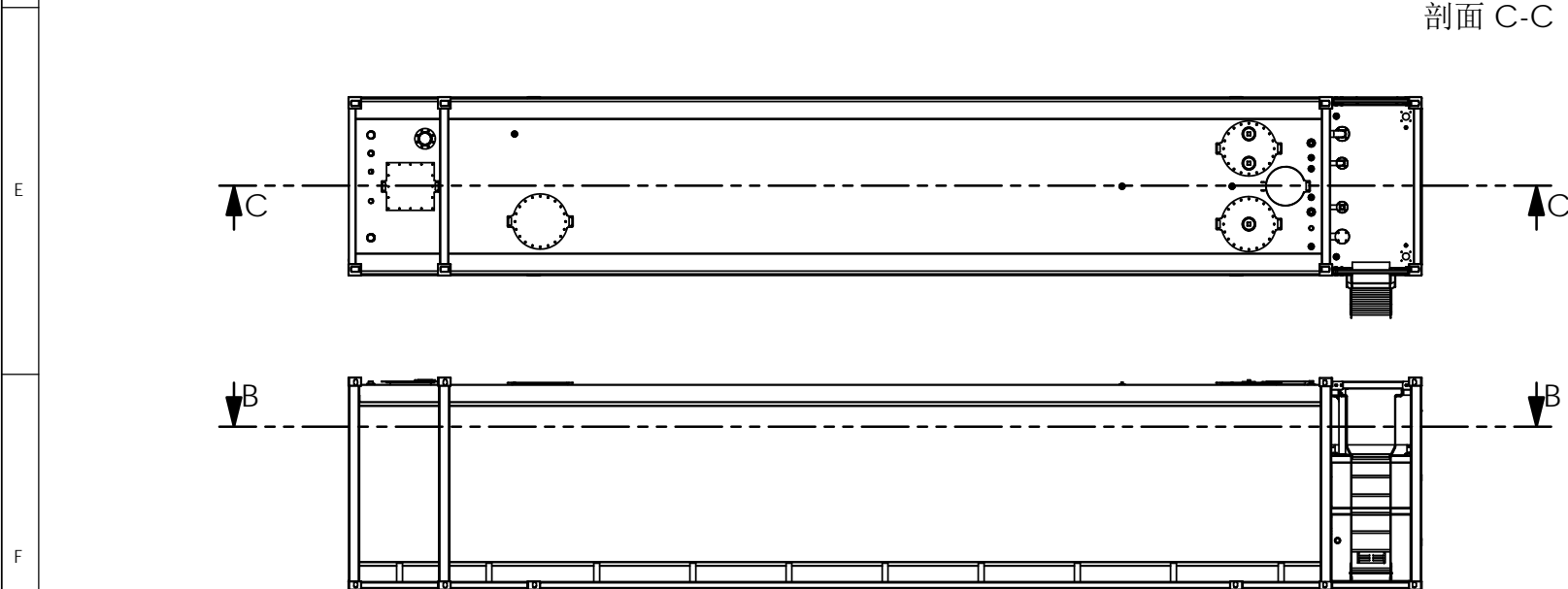

剖面 D-D

THIRD ANGLE PROJECTION	
NAME	DATE
DRAWN	2016/6/23
CHK'D	
APP'VD	

**FUEL**  
REFUELLING SOLUTIONS

TOLERANCE U.N.O.  
0 = -1.0  
0.0 = -0.4  
0.00 = -0.1

MATERIAL:  
WEIGHT: 16536.65 Kg

DWG NO. / PART NO.	JOB NO.
CLIENT: 80,000L iFUEL CONAB SELF BUNDED TANK	
TITLE:	SHEET SIZE <b>A3</b>
SCALE: N.T.S.	REVISION <b>01</b>
SHEET 2 OF 2	