

DO NOT SCALE FROM DRAWING. IF IN DOUBT: ASK

UNLESS OTHERWISE SPECIFIED, ALL DIMENSIONS ARE IN MILLIMETRES

BEWARE OF 100mm MEASURING ERROR

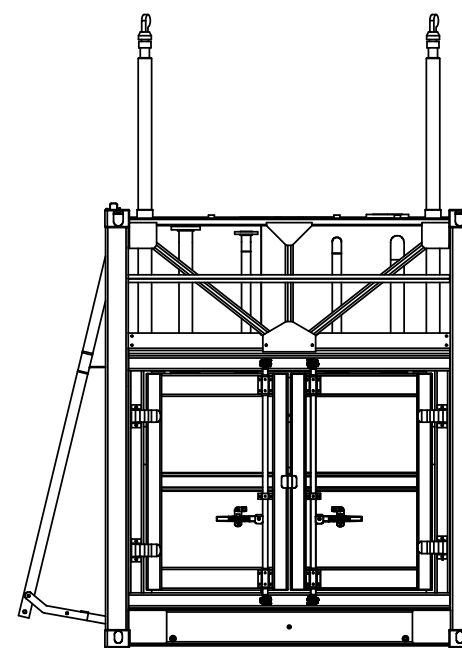
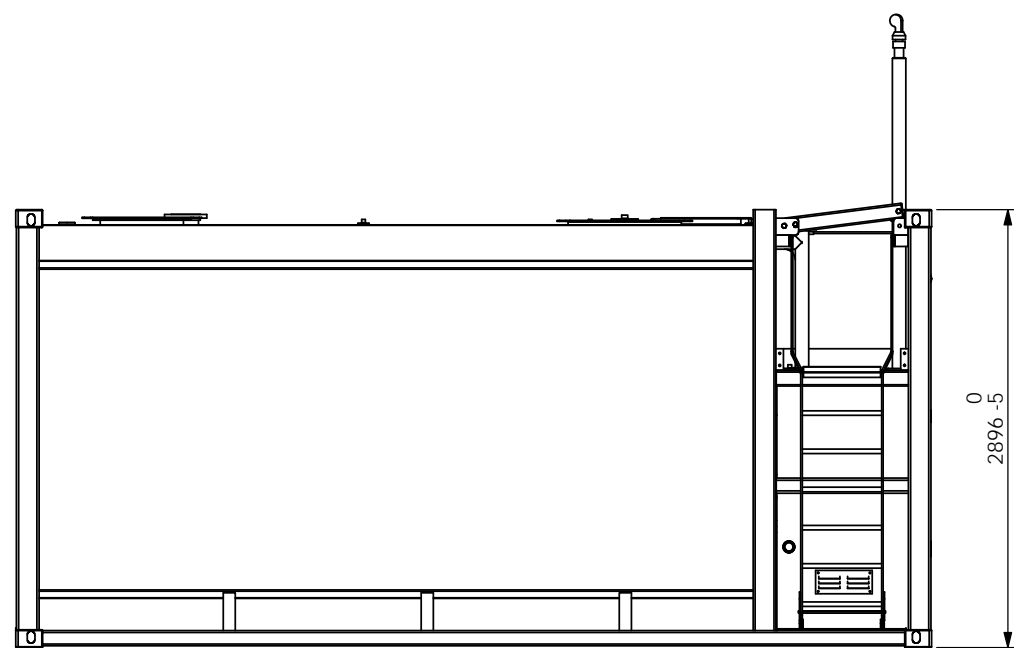
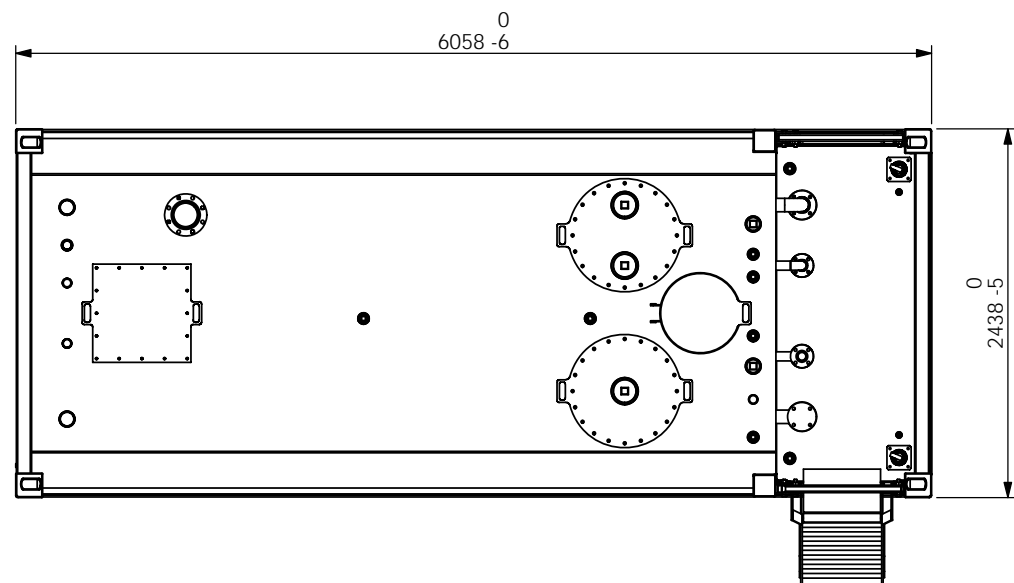

TANK DATA	
TANK CONTENTS:	DIESEL/AdBlue
DESIGNED TO:	AS1940
BUILT TO:	AS1692,CAT.3
CORROSION ALLOW:	0mm
GROSS VOLUME:	21,705L / 7,016L
HYD.TEST PRESSURE:	Gross level+150mm
SAFE FILL LEVEL:	20,620L / 6,666L
N.D.T	
TOTAL MASS:	8,125KG

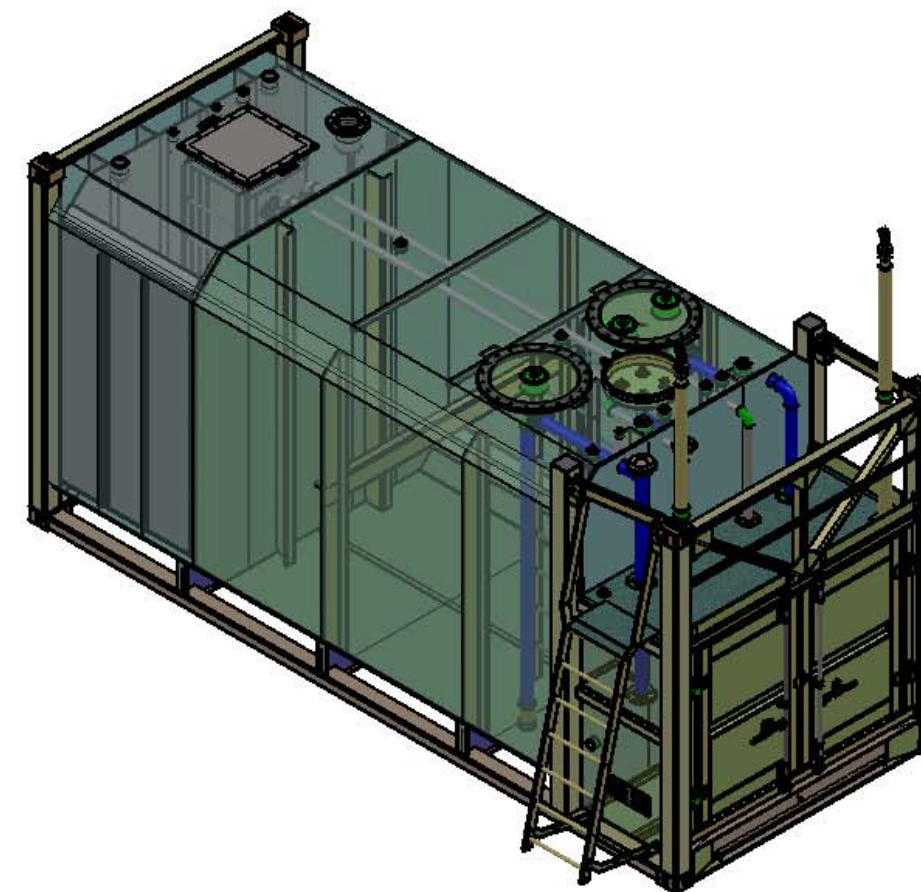

THIRD ANGLE PROJECTION	
NAME	DATE
DRAWN	2016/6/20
CHK'D	
APP'VD	



TOLERANCE U.N.O.
 0 = -1.0
 0.0 = -0.4
 0.00 = -0.1

MATERIAL:
 WEIGHT: 8125.03 Kg

DWG NO. / PART NO.	JOB NO.
CLIENT: 30,000 iFUEL CONAB SELF BUNDED TANK	
TITLE:	SHEET SIZE A3
SCALE: N.T.S.	REVISION 01
SHEET 1 OF 2	

DO NOT SCALE FROM DRAWING. IF IN DOUBT: ASK

UNLESS OTHERWISE SPECIFIED, ALL DIMENSIONS ARE IN MILLIMETRES

BEWARE OF 100mm MEASURING ERROR

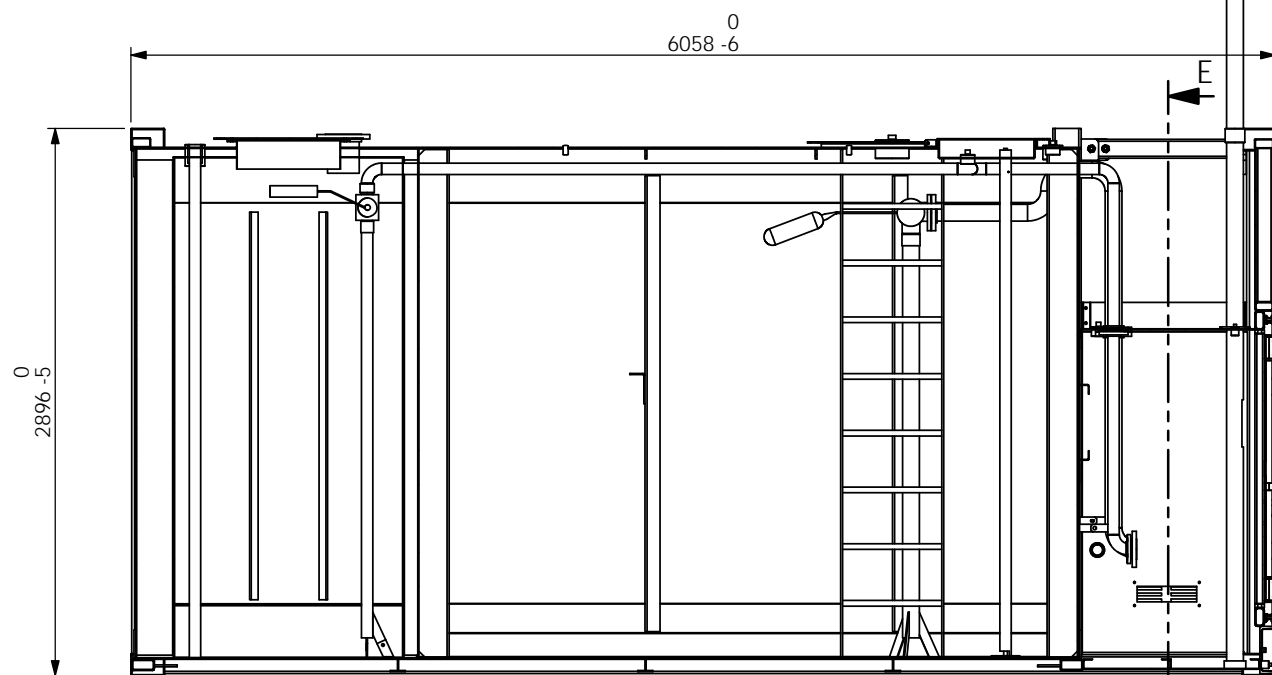
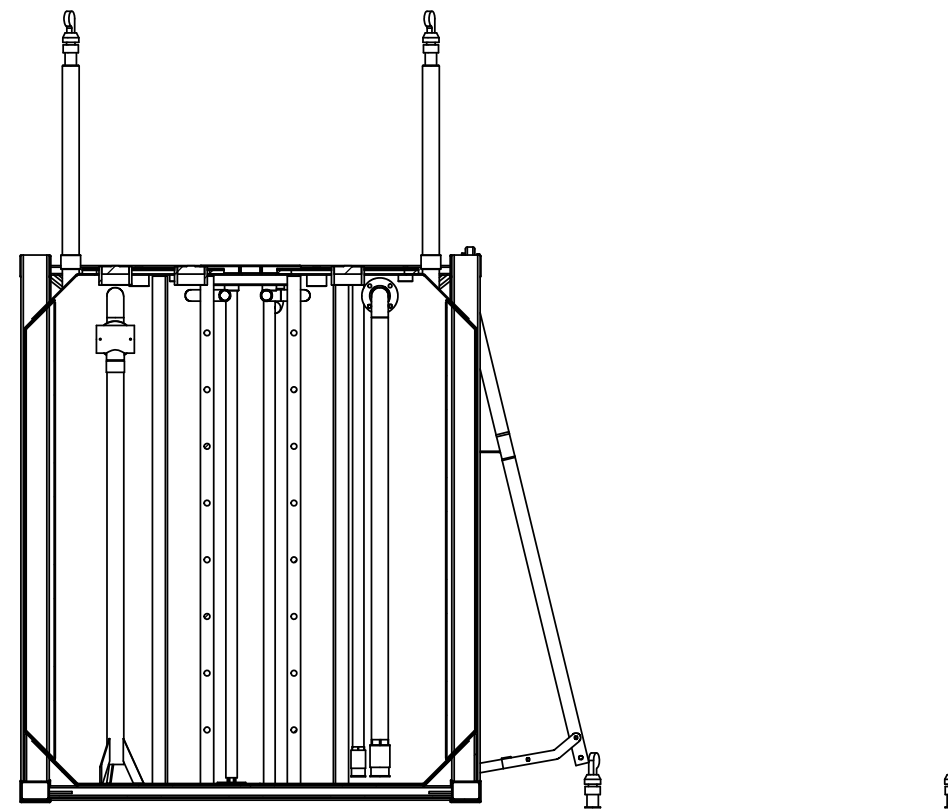
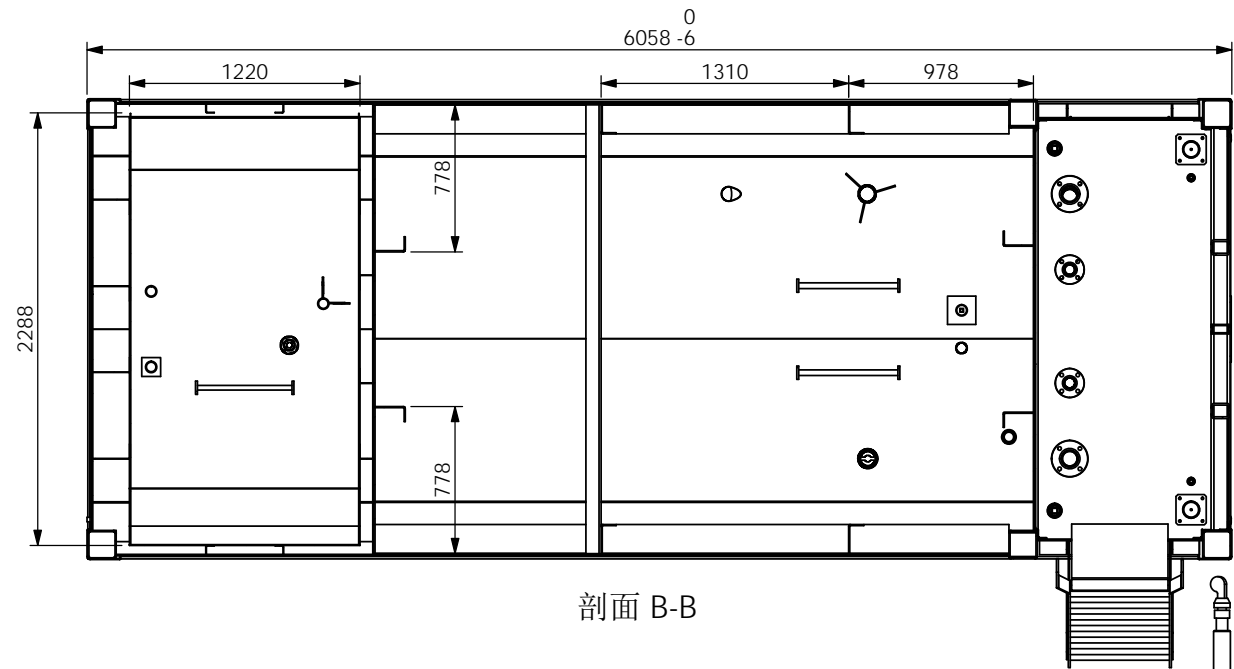

剖面 D-D

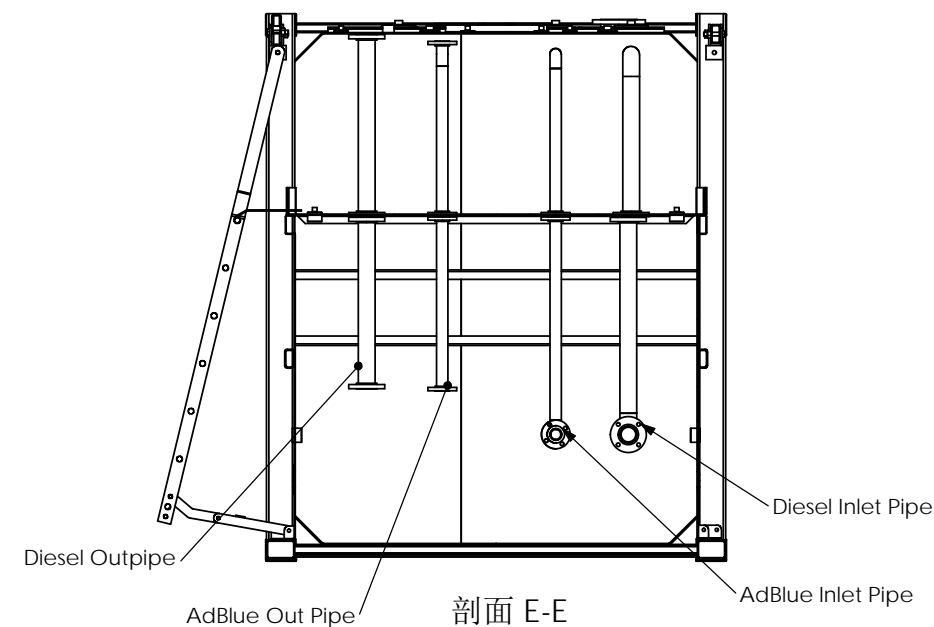
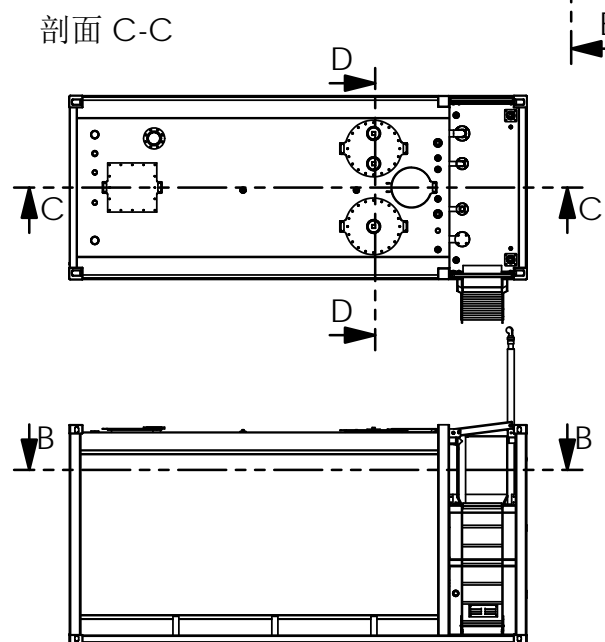

PROJECTION		DWG NO. / PART NO.		JOB NO.	
		CLIENT: 30,000 GO GCAB SELF BUNDED TANK			
		TITLE:			
NAME	DATE	TOLERANCE U.N.O.		MATERIAL:	
DRAWN	2016/6/20	0 = -1.0 0.0 = -0.4 0.00 = -0.1		WEIGHT: 8125.03 Kg	
SCALE: N.T.S.		SHEET 2 OF 2		SHEET SIZE A3 REVISION 01	