

DO NOT SCALE FROM DRAWING. IF IN DOUBT: ASK

UNLESS OTHERWISE SPECIFIED, ALL DIMENSIONS ARE IN MILLIMETRES

BEWARE OF 100mm MEASURING ERROR

TANK DATA

TANK CONTENTS:	DIESEL/AdBlue
DESIGNED TO:	AS1940
BUILT TO:	AS1692,CAT.3
CORROSION ALLOW:	0mm
GROSS VOLUME:	100,062L/10,525L
HYD.TEST PRESSURE:	Gross level+150mm
SAFE FILL LEVEL:	95,059L/10,000L
N.D.T	
TOTAL MASS:	18,893KG

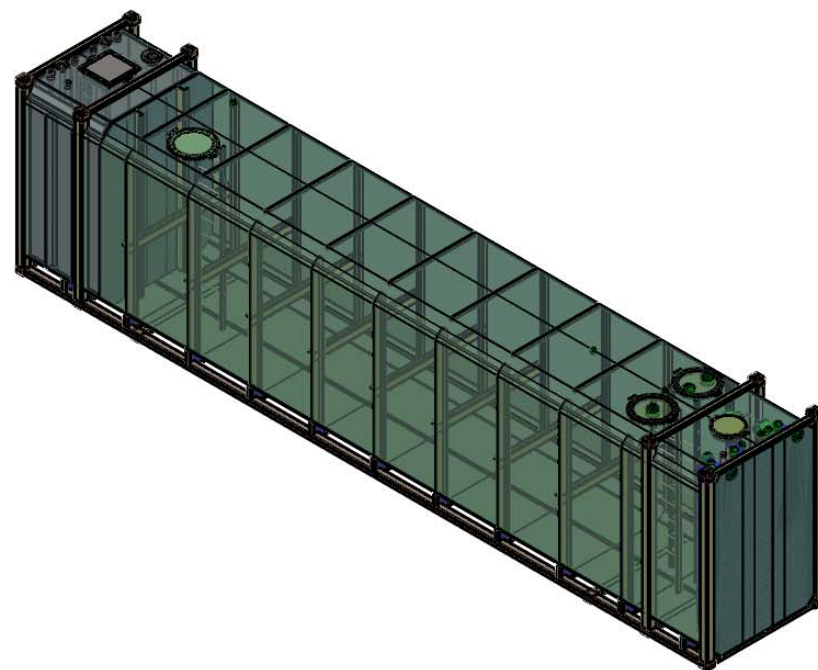
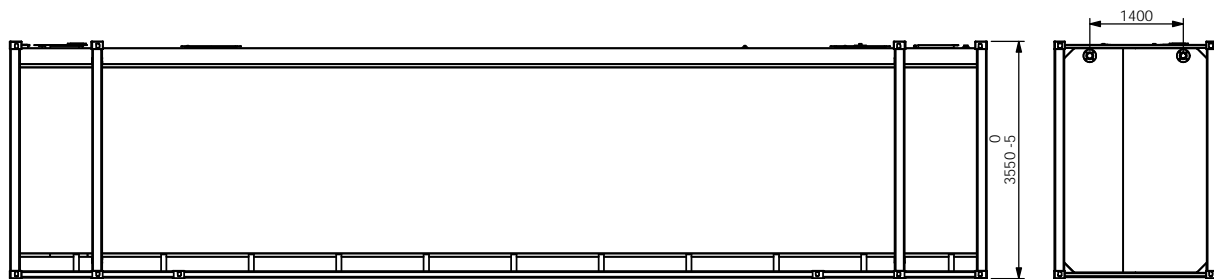
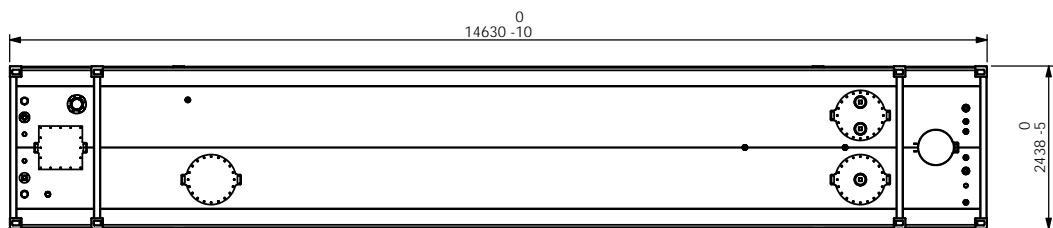

THIRD ANGLE PROJECTION	
○	
NAME	DATE
DRAWN	2016/6/23
CHK'D	
APP'VD	



TOLERANCE U.N.O.
 0 = -1.0
 0.0 = -0.4
 0.00 = -0.1

MATERIAL:
 WEIGHT: 19223.34 Kg

DWG NO. / PART NO.		JOB NO.	
CLIENT: 110,000L iFUEL CONAB SELF BUNDED TANK			
TITLE:			SHEET SIZE
			A3
SCALE: N.T.S.			REVISION
SHEET 1 OF 2			01

DO NOT SCALE FROM DRAWING. IF IN DOUBT: ASK

UNLESS OTHERWISE SPECIFIED, ALL DIMENSIONS ARE IN MILLIMETRES

BEWARE OF 100mm MEASURING ERROR

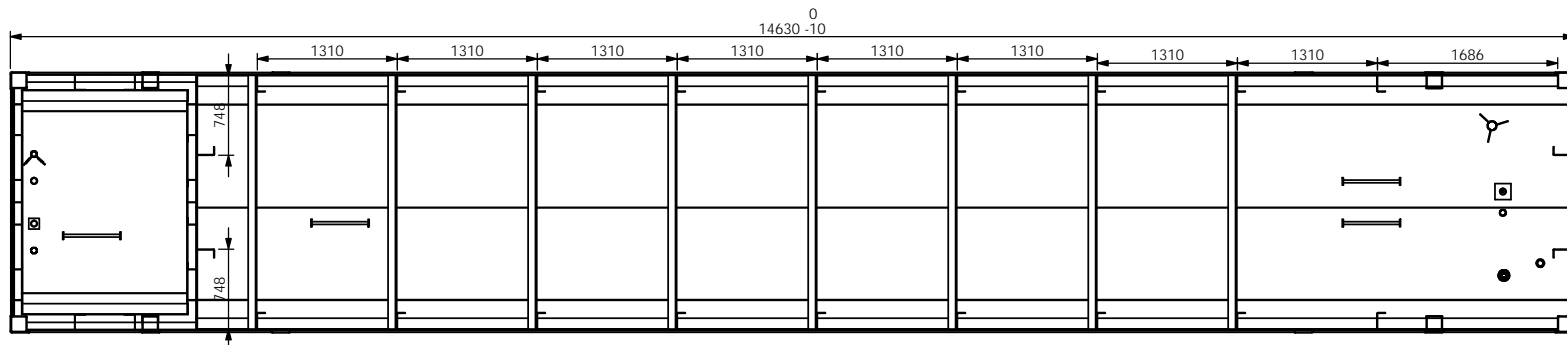

剖面 B-B

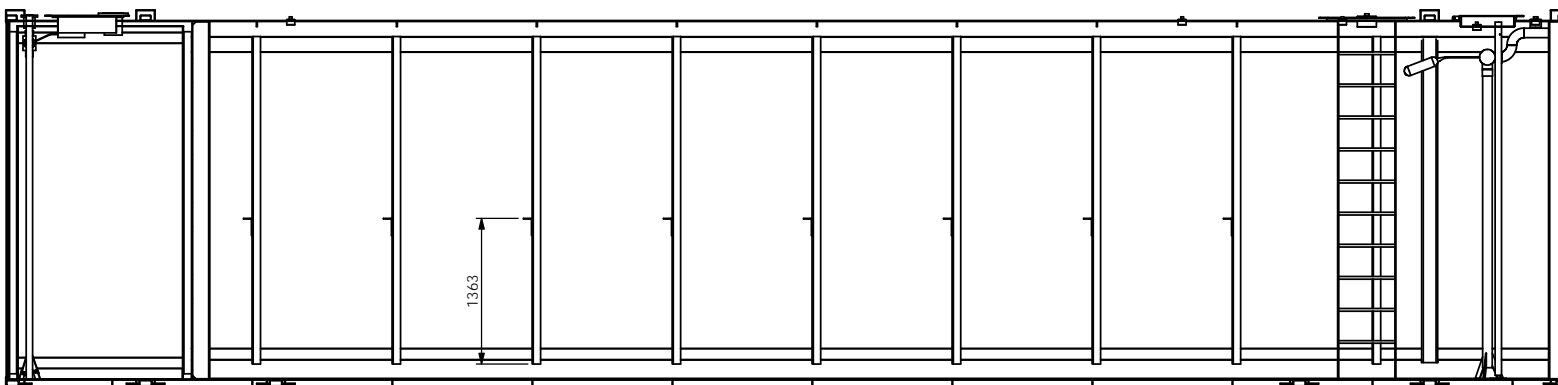

剖面 C-C

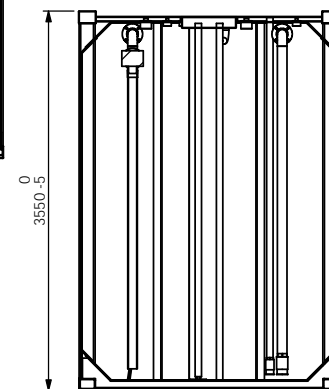

剖面 D-D

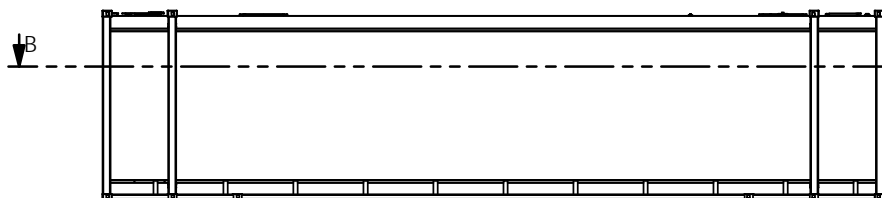
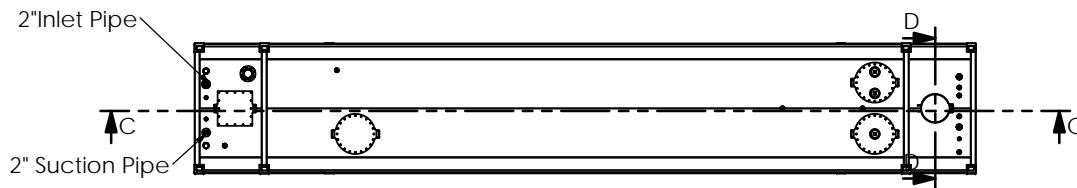

FIRST ANGLE PROJECTION	
NAME	DATE
DRAWN	2016/6/23
CHK'D	
APP'VD	



TOLERANCE U.N.O.
 0 = -1.0
 0.0 = -0.4
 0.00 = -0.1

WEIGHT: 19223.34 Kg

DWG NO. / PART NO.		JOB NO.	
CLIENT: 110,000L iFUEL CONAB SELF BUNDED TANK			
TITLE:		SHEET SIZE A3	
SCALE: N.T.S.		REVISION 01	
SHEET 2 OF 2			