

TANK DATA	
TANK CONTENTS:	DIESEL
GROSS VOLUME:	8000L
SAFE FILL LEVEL:	7600L

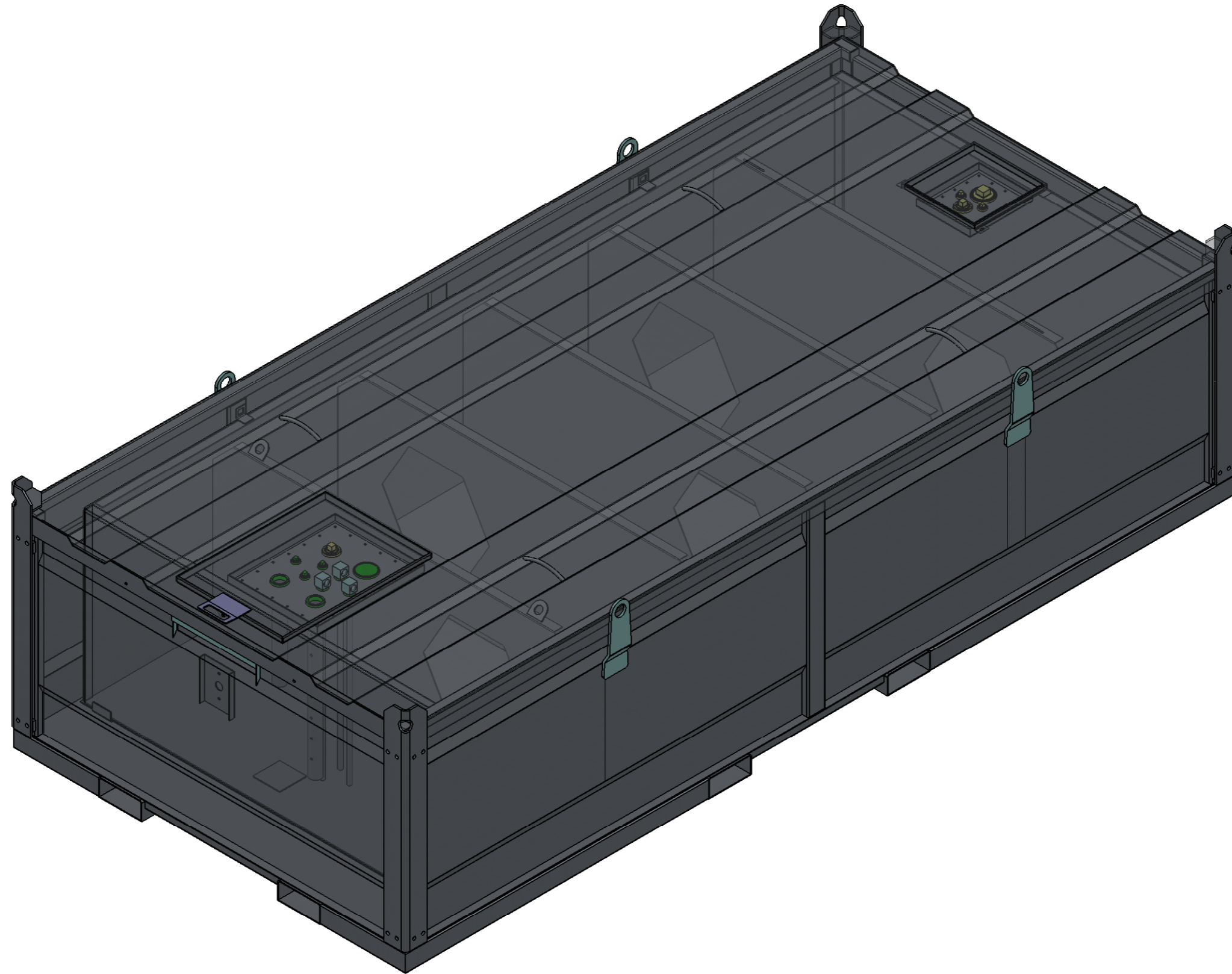

07					
06					
05					
04					
03					
02					
01	2016/05/25	E			
REV:	DATE:	REVISION:	DRAWN:	CHECKED:	APPROVED:

Note:  
 > Designed and approved to AS1940 / AS1692 / AS1657  
 > All welding to AS1554.1



Material:  
 Weight: 2969.51KG

DRAWN: SAVING DATE: 2016/8/8  
 CHECKED: DATE:  
 CLIENT: DATE:  
 APPROVED: DATE:

TITLE:  
 iFUEL 8000L SELF BUNDED BAFFLED CUBE  
 DRAWING NO. :  
 PURCHASE ORDER NO. :  
 REV: A3  
 SHEET: 1 of 7  
 Scale: No scale

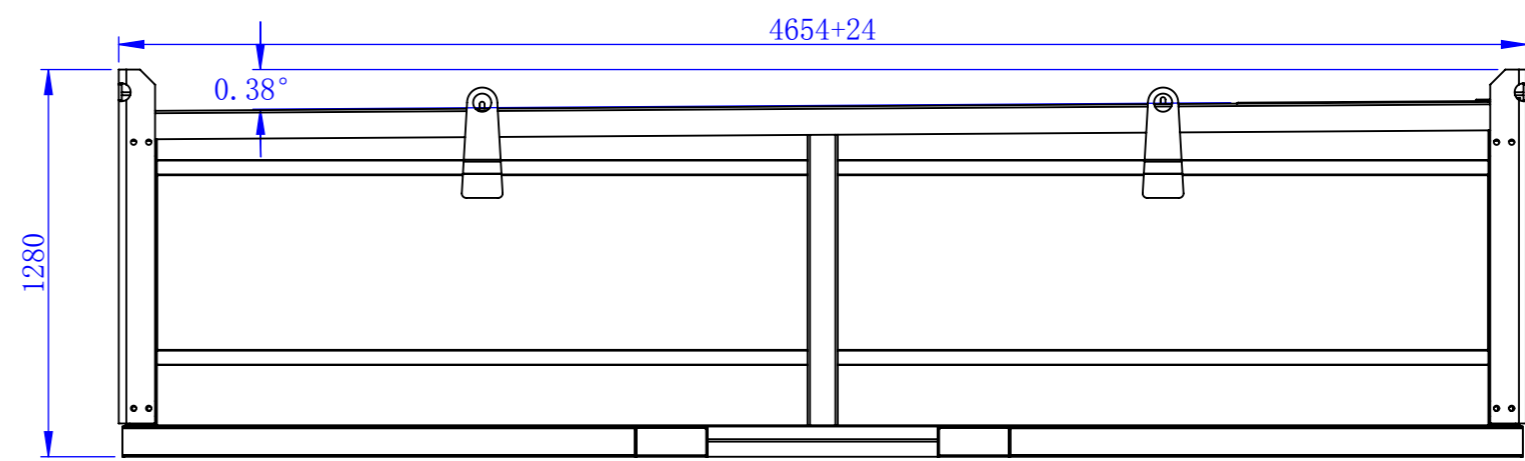
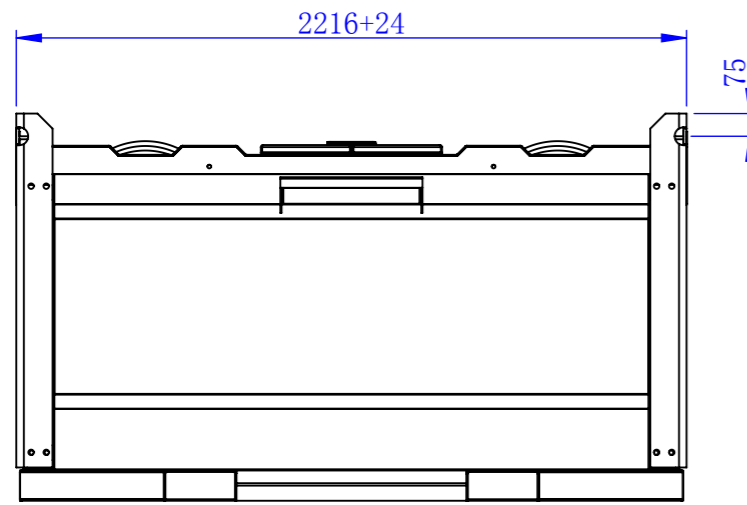
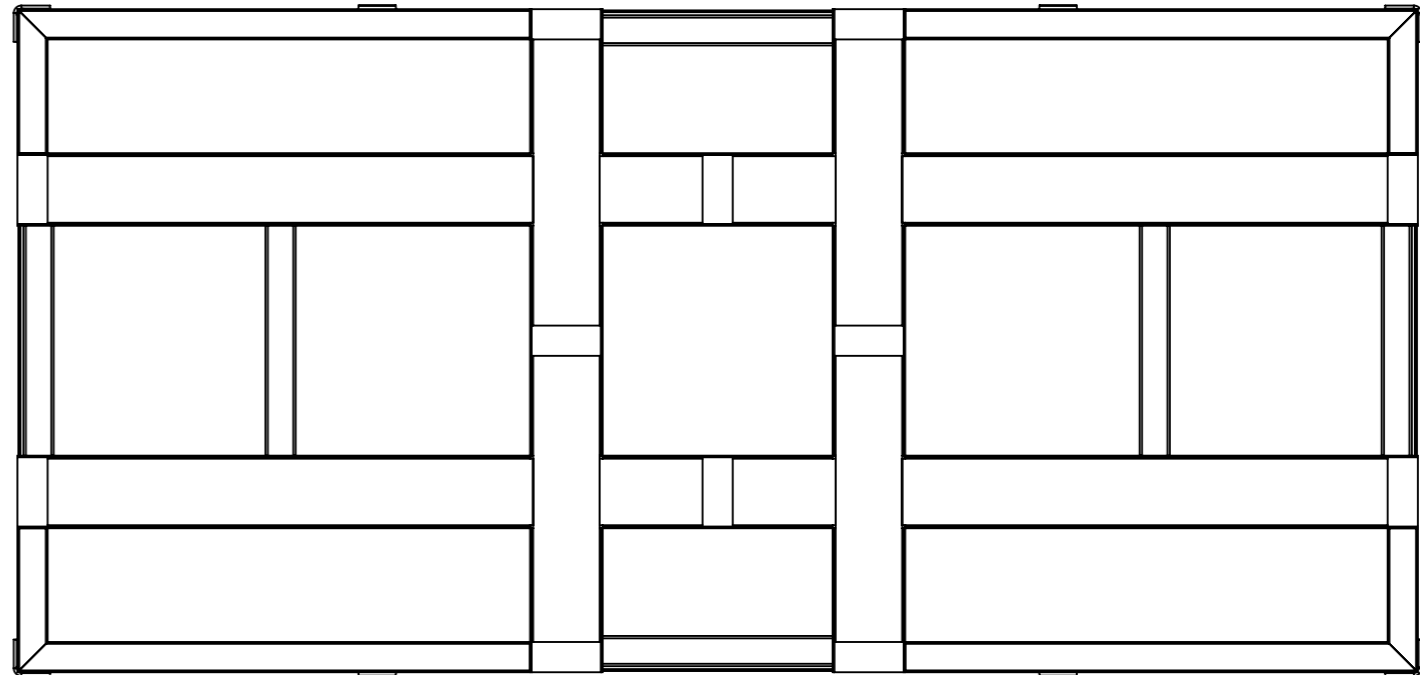

07					
06					
05					
04					
03					
02					
01					
REV:	DATE:	REVISION:	DRAWN:	CHECKED:	APPROVED:



Material:  
Weight: 2969.51KG

DRAWN:	SAVING DATE: 2016/8/8
CHECKED:	DATE:
CLIENT:	DATE:
APPROVED:	DATE:

TITLE: iFUEL 8000L SELF BUNDED BAFFLED CUBE	
DRAWING NO. :	REV:
PURCHASE ORDER NO. :	SHEET: 2 of 7
Scale: No scale	A3

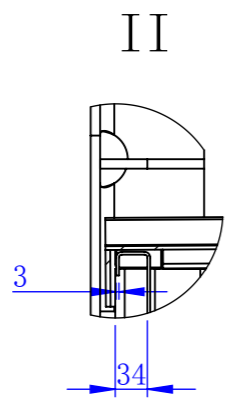
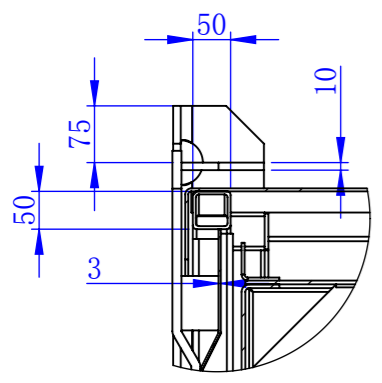
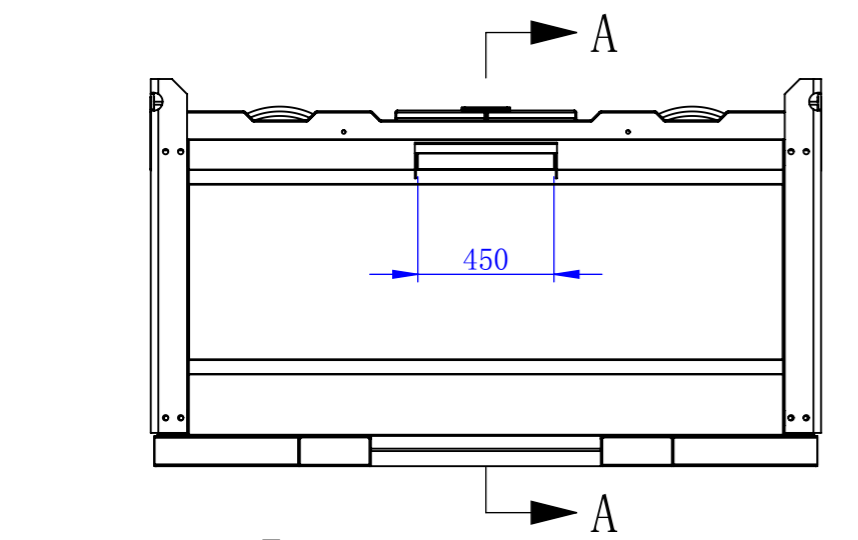

B-B

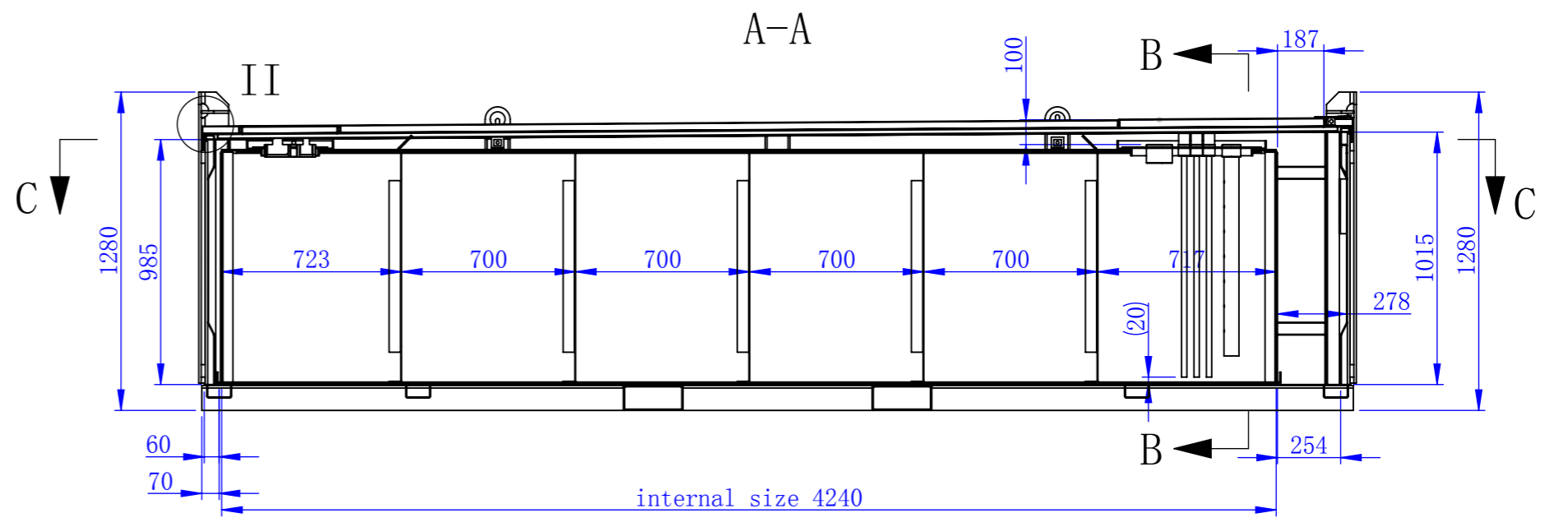
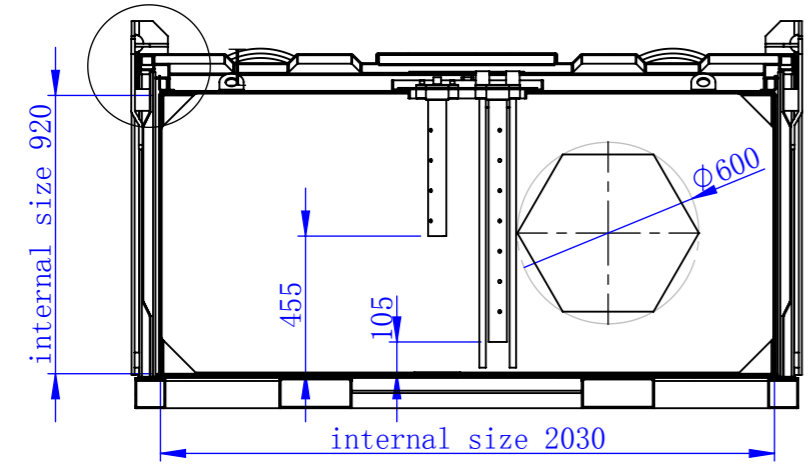

C-C

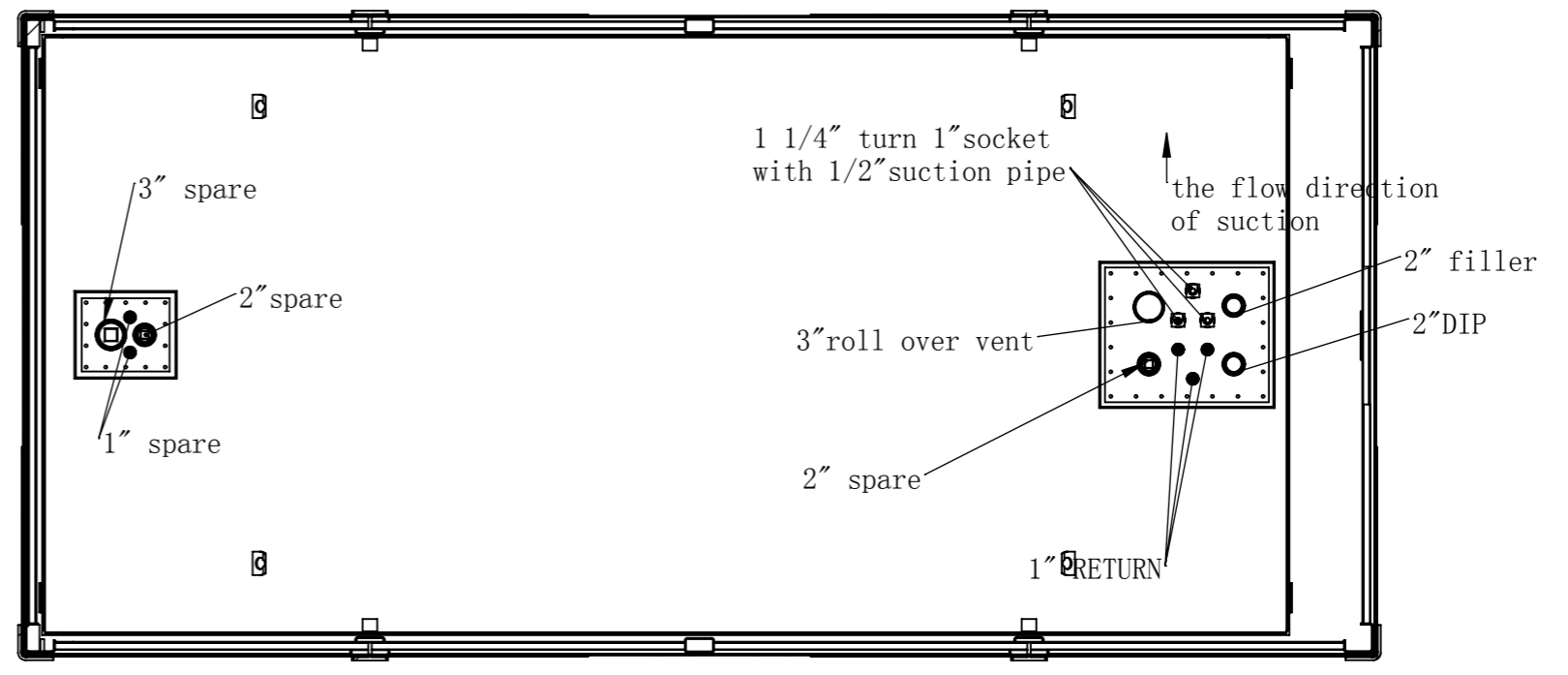

07					
06					
05					
04					
03					
02					
01					
REV:	DATE:	REVISION:	DRAWN:	CHECKED:	APPROVED:



Material:  
Weight: 2969.51KG

DRAWN:      SAVING DATE: 2016/8/8  
 CHECKED:    DATE:  
 CLIENT:      DATE:  
 APPROVED:    DATE:

TITLE:  
iFUEL 8000L SELF BUNDED BAFFLED CUBE

DRAWING NO. :      REV:      A3

SHEET: 3 of 7

PURCHASE ORDER NO. :      Scale: No scale

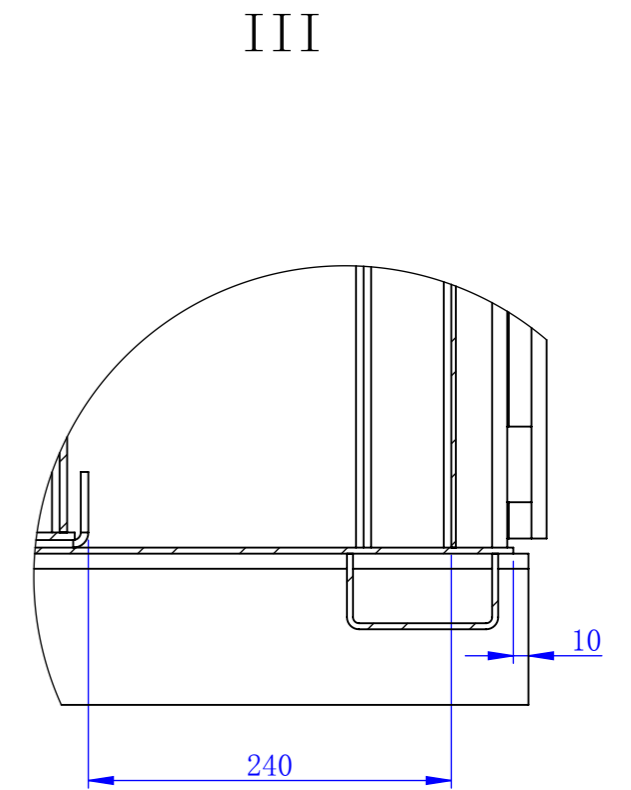
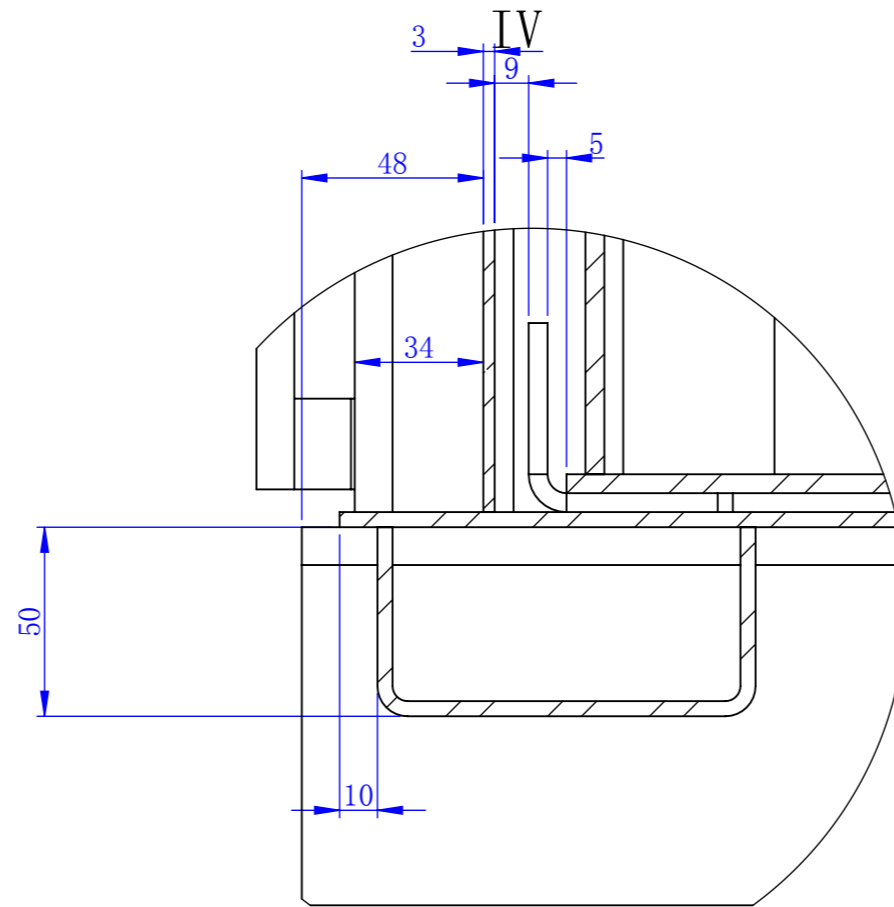
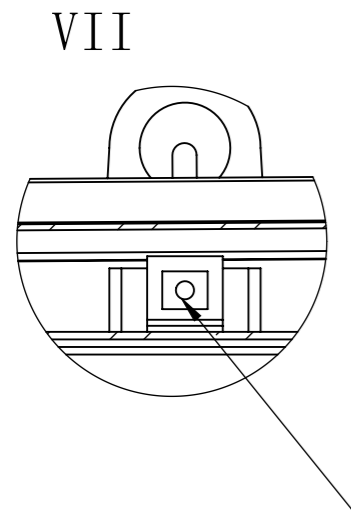
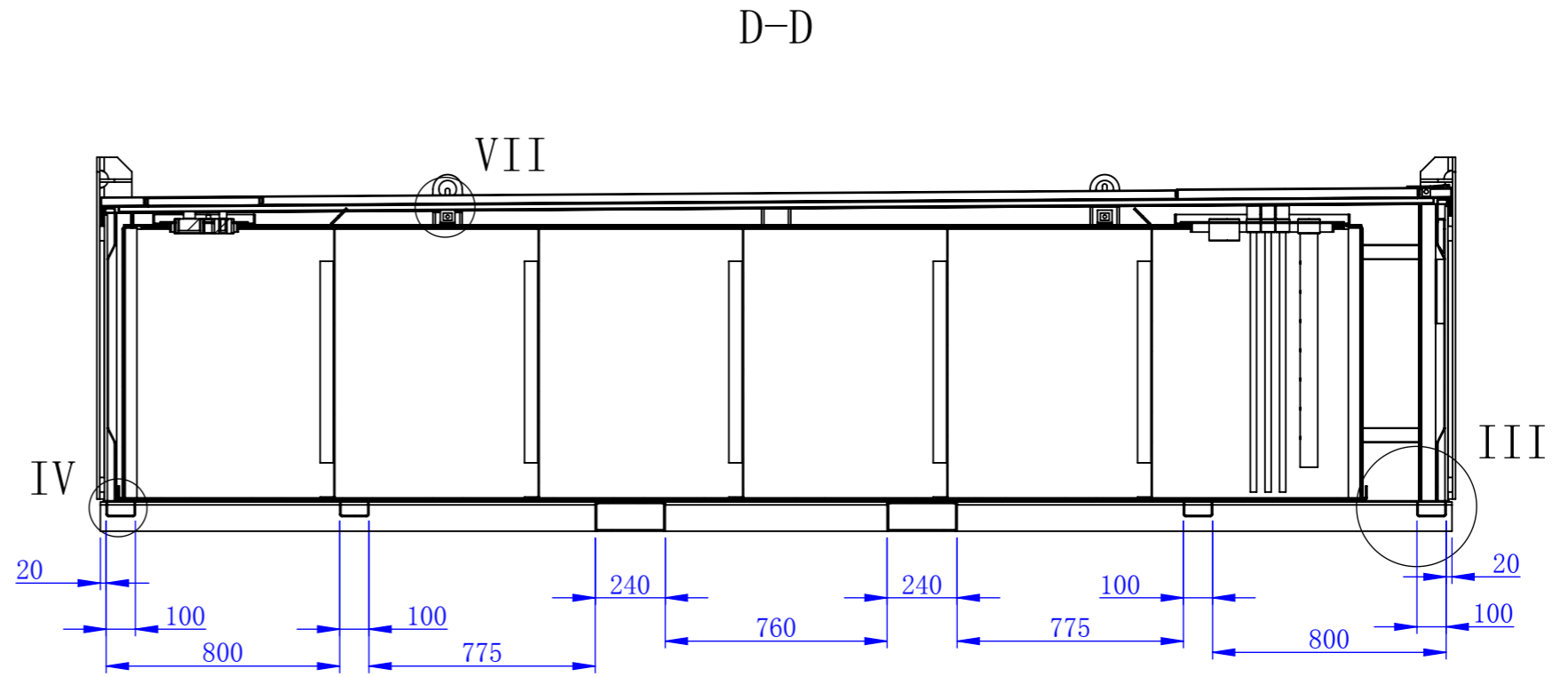
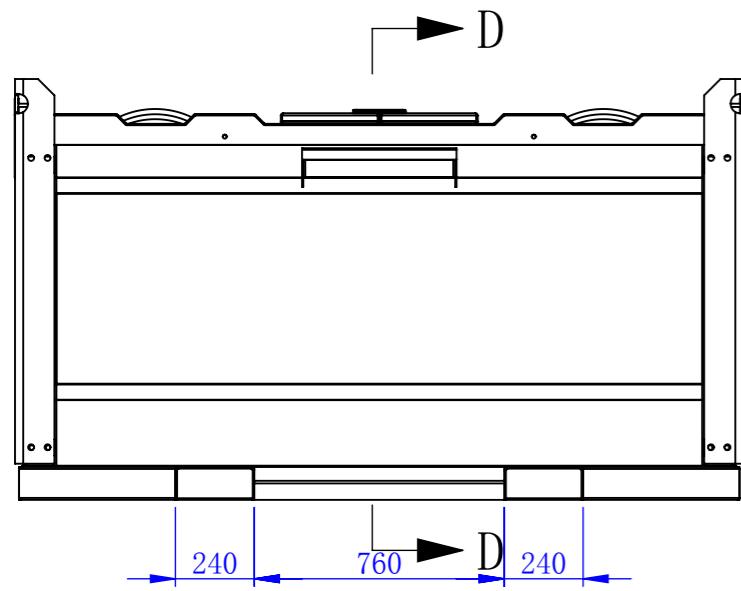

07					
06					
05					
04					
03					
02					
01					
REV:	DATE:	REVISION:	DRAWN:	CHECKED:	APPROVED:



Material:  
Weight: 2969.51KG

DRAWN:  
CHECKED:  
CLIENT:  
APPROVED:

SAVING DATE:  
2016/8/8  
DATE:  
DATE:  
DATE:

TITLE:  
iFUEL 8000L SELF BUNDED BAFFLED CUBE

DRAWING NO. :  
REV:  
SHEET:  
4 of 7  
Scale:  
No scale

PURCHASE  
ORDER NO. :

A3



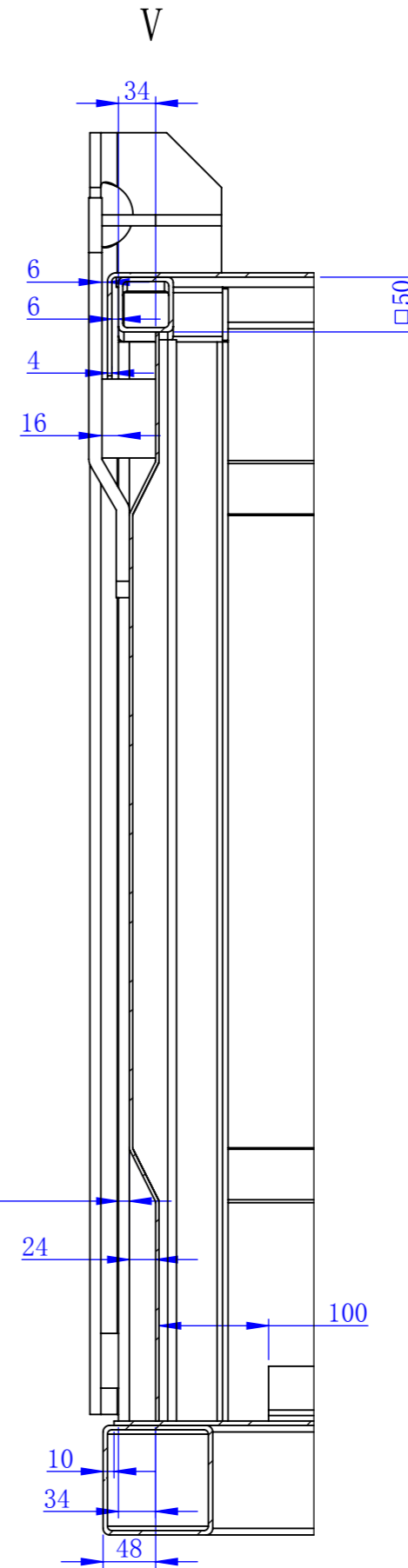
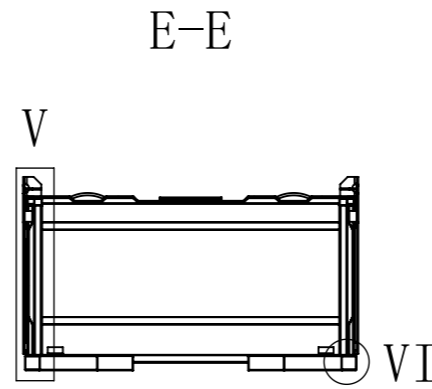
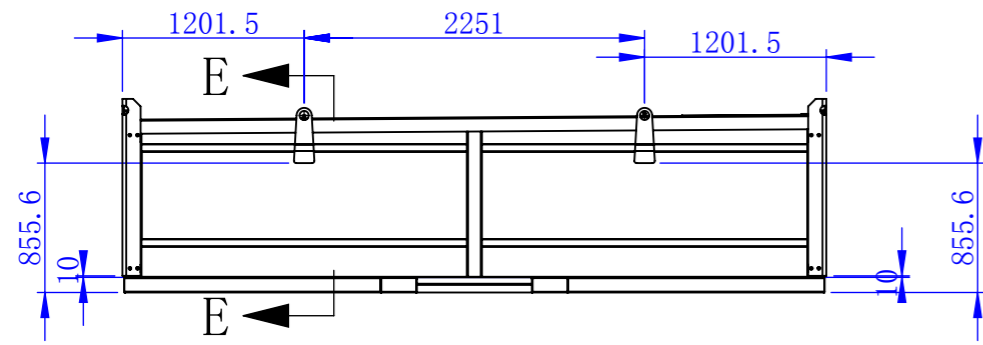

VI

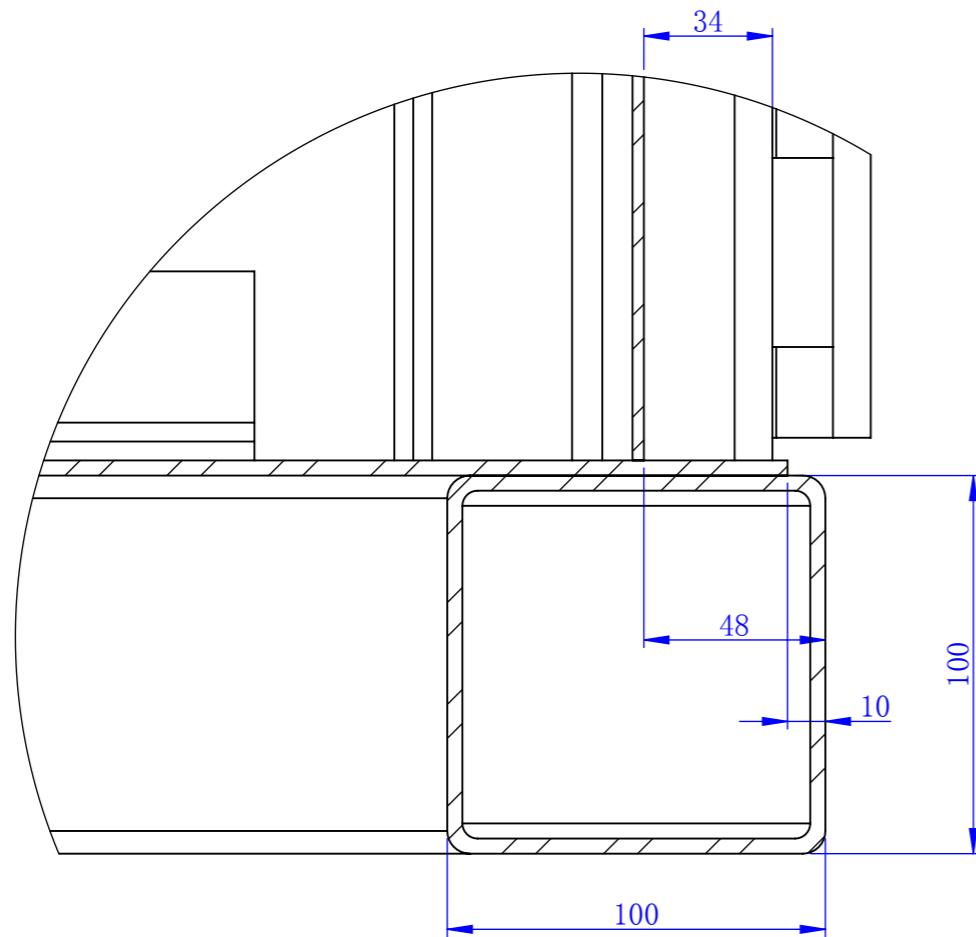

07					
06					
05					
04					
03					
02					
01					
REV:	DATE:	REVISION:	DRAWN:	CHECKED:	APPROVED:



Material:  
Weight: 1559.47KG

DRAWN:  
CHECKED:  
CLIENT:  
APPROVED:

SAVING DATE:  
DATE:  
DATE:  
DATE:

TITLE:  
iFUEL 8000L SELF BUNDED BAFFLED CUBE

DRAWING NO. :  
PURCHASE ORDER NO. :

REV:  
SHEET:  
5 of 7  
Scale:  
No scale

A3



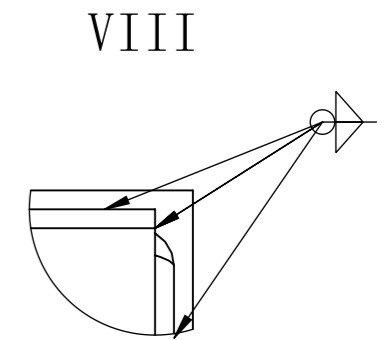
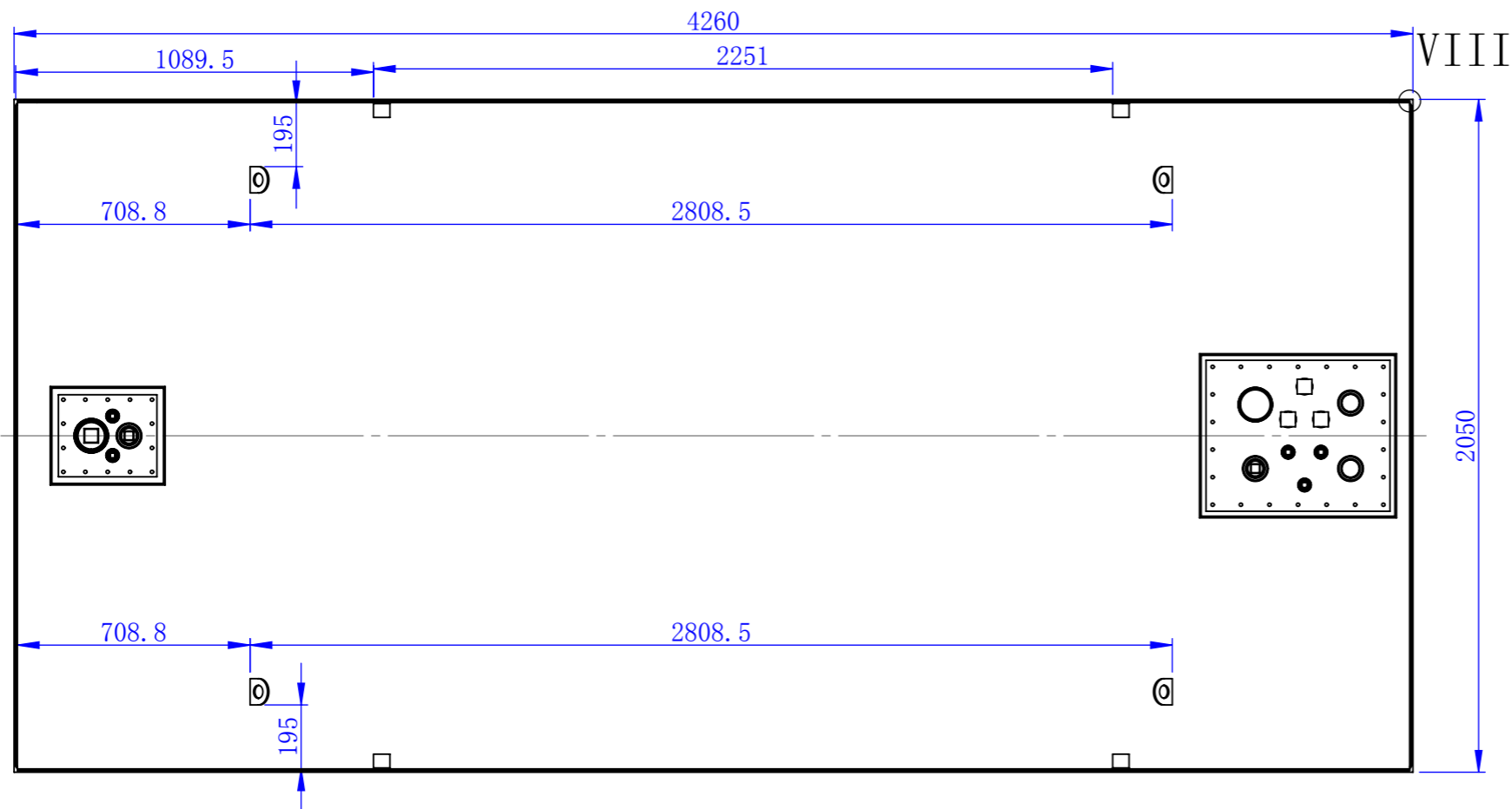
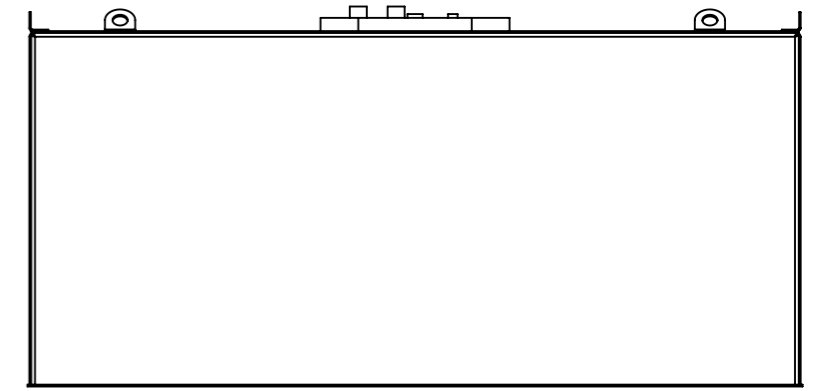
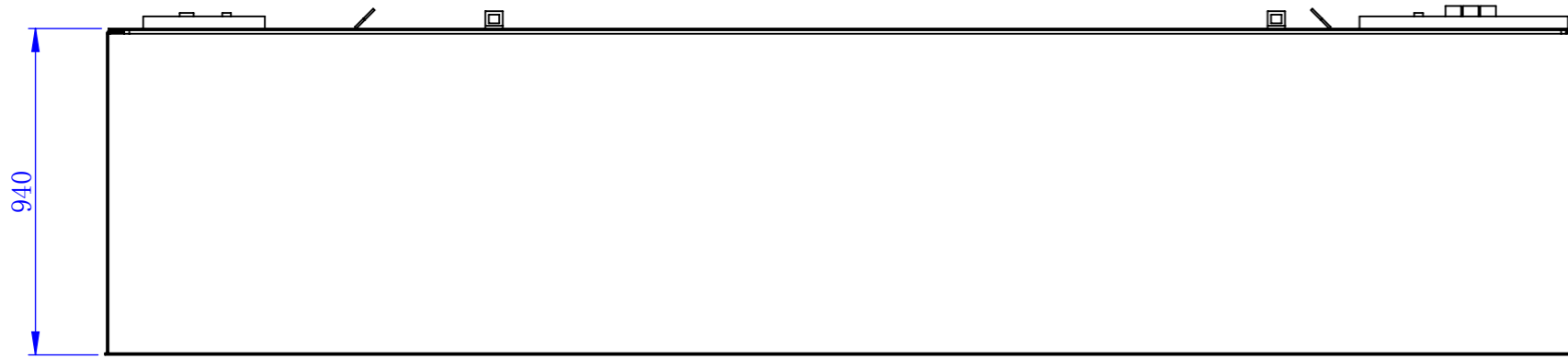

07					
06					
05					
04					
03					
02					
01					
REV:	DATE:	REVISION:	DRAWN:	CHECKED:	APPROVED:



Material:  
Weight: 1410.04KG

DRAWN: SAVING DATE: 2016/8/8  
 CHECKED: DATE:  
 CLIENT: DATE:  
 APPROVED: DATE:

TITLE: iFUEL 8000L SELF BUNDED BAFFLED CUBE  
 DRAWING NO. :  
 PURCHASE ORDER NO. :  
 REV: A3  
 SHEET: 6 of 7  
 Scale: No scale

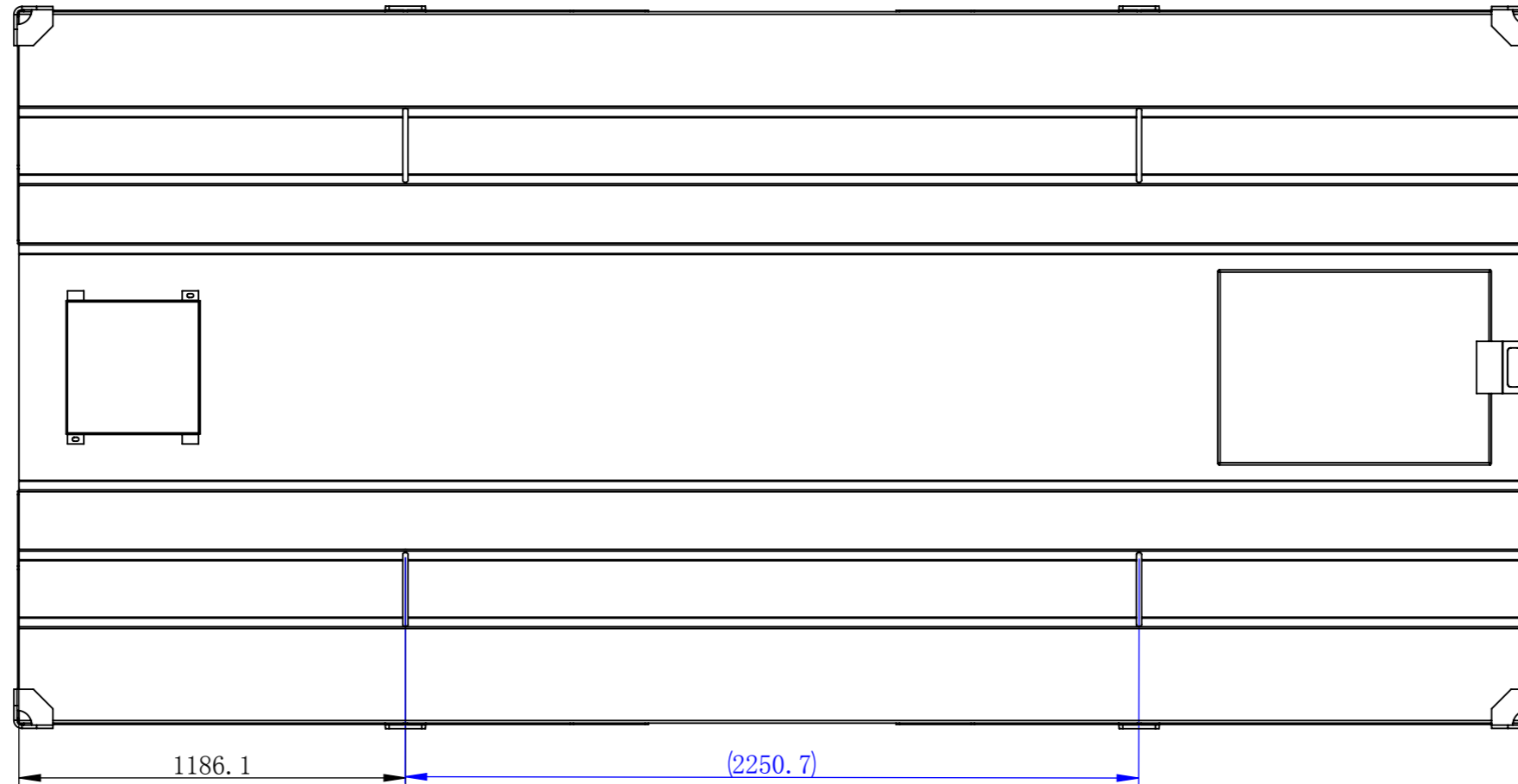

07					
06					
05					
04					
03					
02					
01					
REV:	DATE:	REVISION:	DRAWN:	CHECKED:	APPROVED:



Material:  
Weight: 2969.51KG

DRAWN:  
CHECKED:  
CLIENT:  
APPROVED:

SAVING DATE:  
DATE:  
DATE:  
DATE:

TITLE:  
iFUEL 8000L SELF BUNDED BAFFLED CUBE

DRAWING NO. :

REV:  
SHEET:  
7 of 7

PURCHASE  
ORDER NO. :

Scale:  
No scale

A3

