

Size	Total Fill Level (L)	Safe Fill Level (L) 95%	Length (mm)	Width (mm)	Height (mm)
CUBE3300	3300L	3000L	1589	2166	1221

07					
06					
05					
04					
03					
02					
01					
REV:	DATE:	REVISION:	DRAWN:	CHECKED:	APPROVED:

Note:
 > Designed and approved to AS1940 / AS1692 / AS1657
 > All welding to AS1554.1



Material: _____
 Weight: 1111.18KG

DRAWN:	DATE: 2017/6/12
CHECKED:	DATE:
CLIENT:	DATE:
APPROVED:	DATE:

TITLE: iFUEL 3300L Self Bunded Cube	
DRAWING NO. :	REV: 01
	SHEET: 1 of 3
PURCHASE ORDER NO. :	Scale: No scale

A3



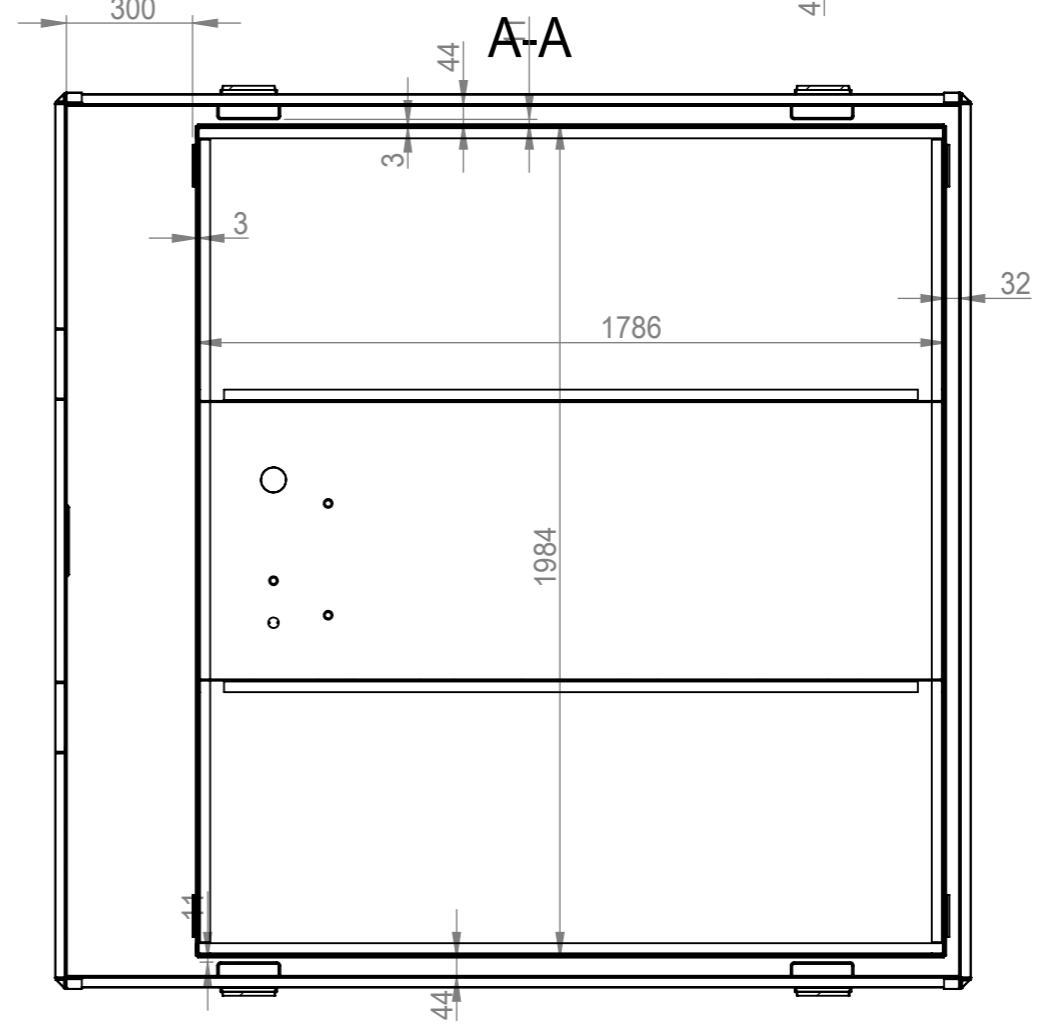
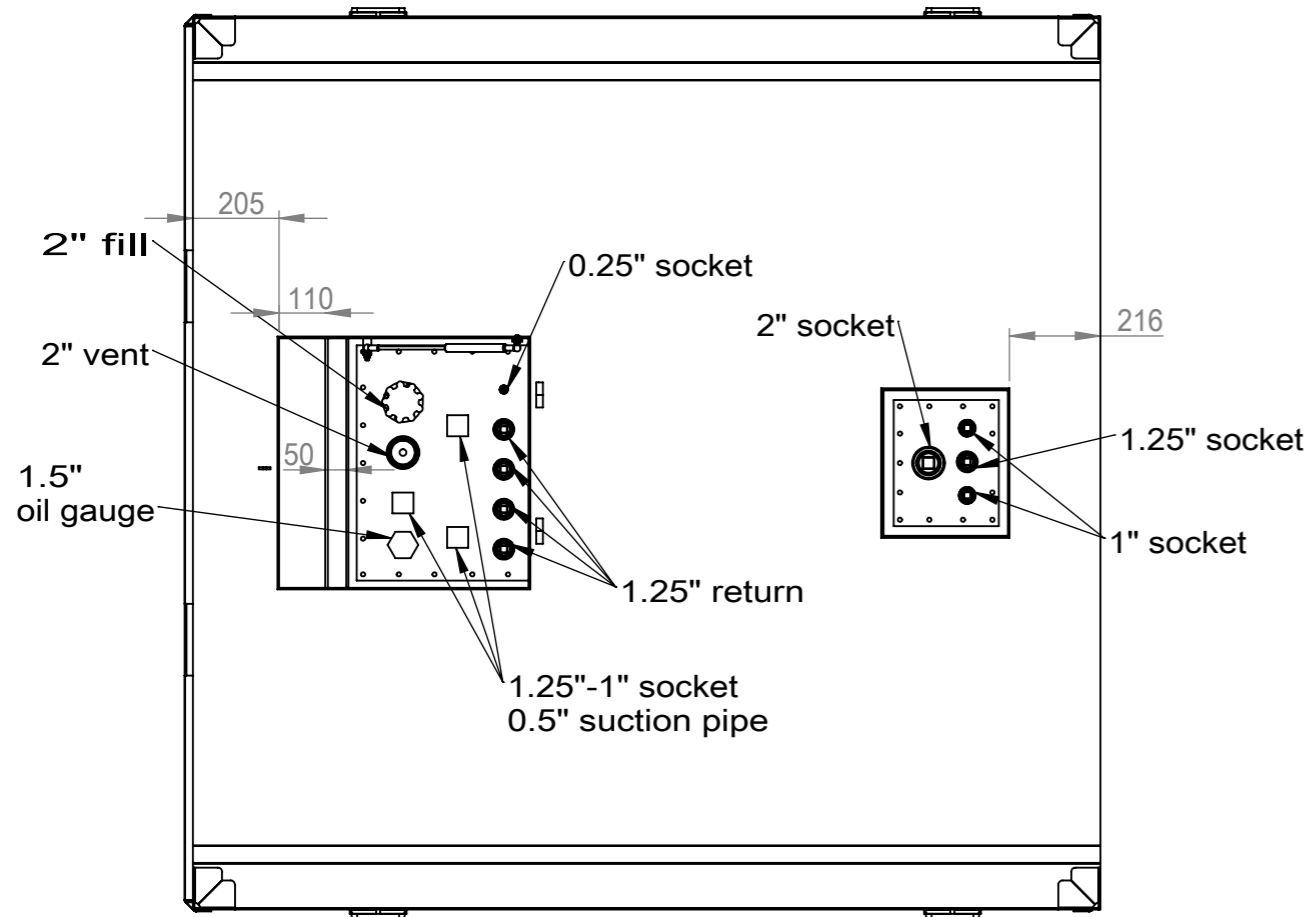
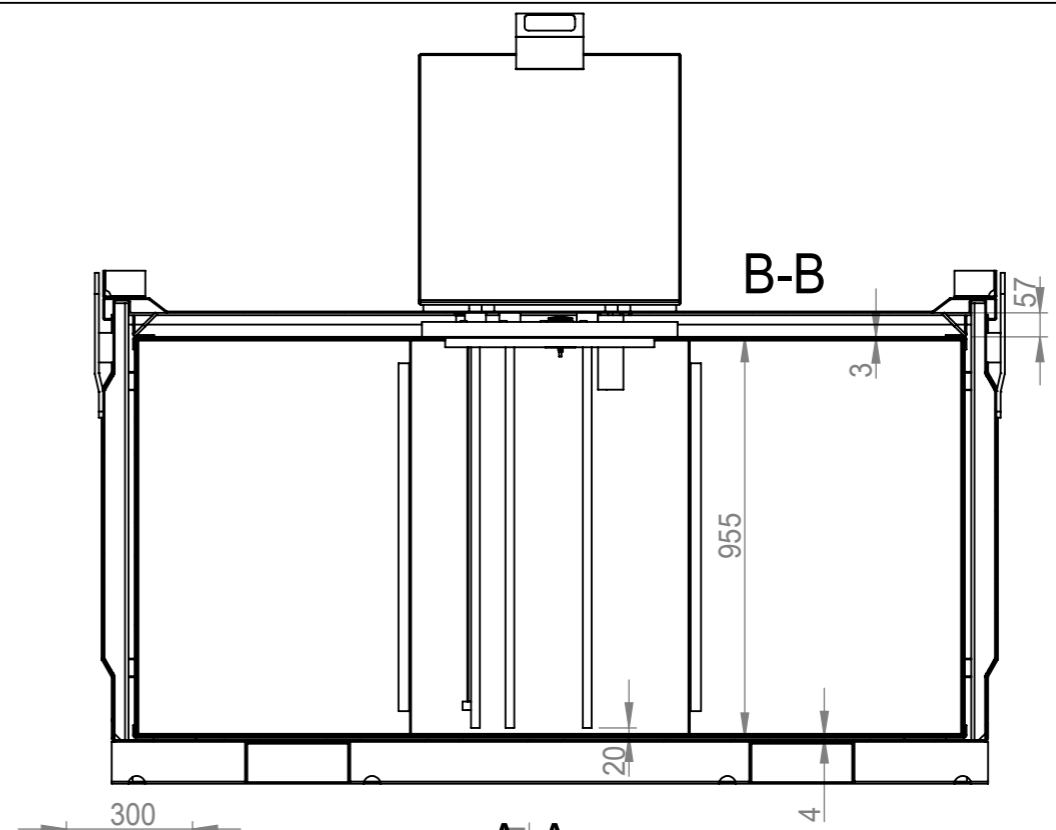
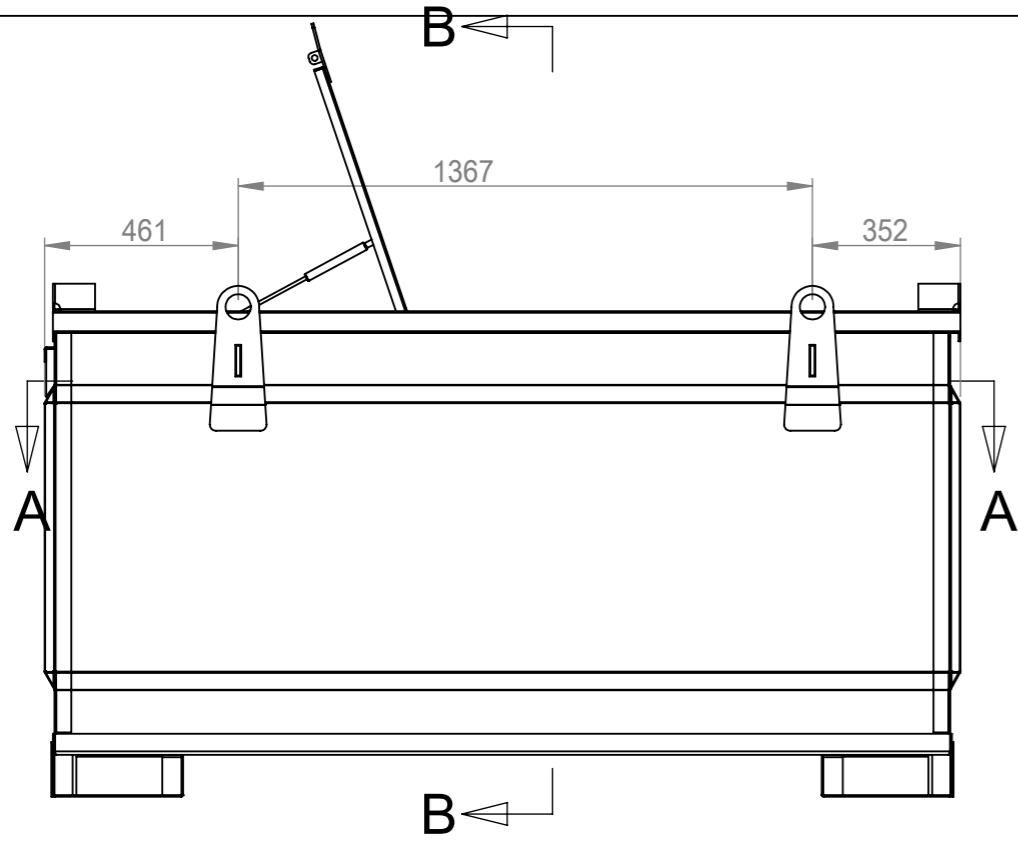

07					
06					
05					
04					
03					
02					
01					
REV:	DATE:	REVISION:	DRAWN:	CHECKED:	APPROVED:

Note:
1.All thread is BSP ;



Material:
Weight: 1111.18KG

DRAWN:
CHECKED:
CLIENT:
APPROVED:

SAVING DATE:
DATE:
DATE:
DATE:

TITLE:
iFUEL 3300L Self Bunded Cube
DRAWING NO. :
PURCHASE ORDER NO. :

REV:
SHEET:
2 of 3
Scale:
No scale

A3



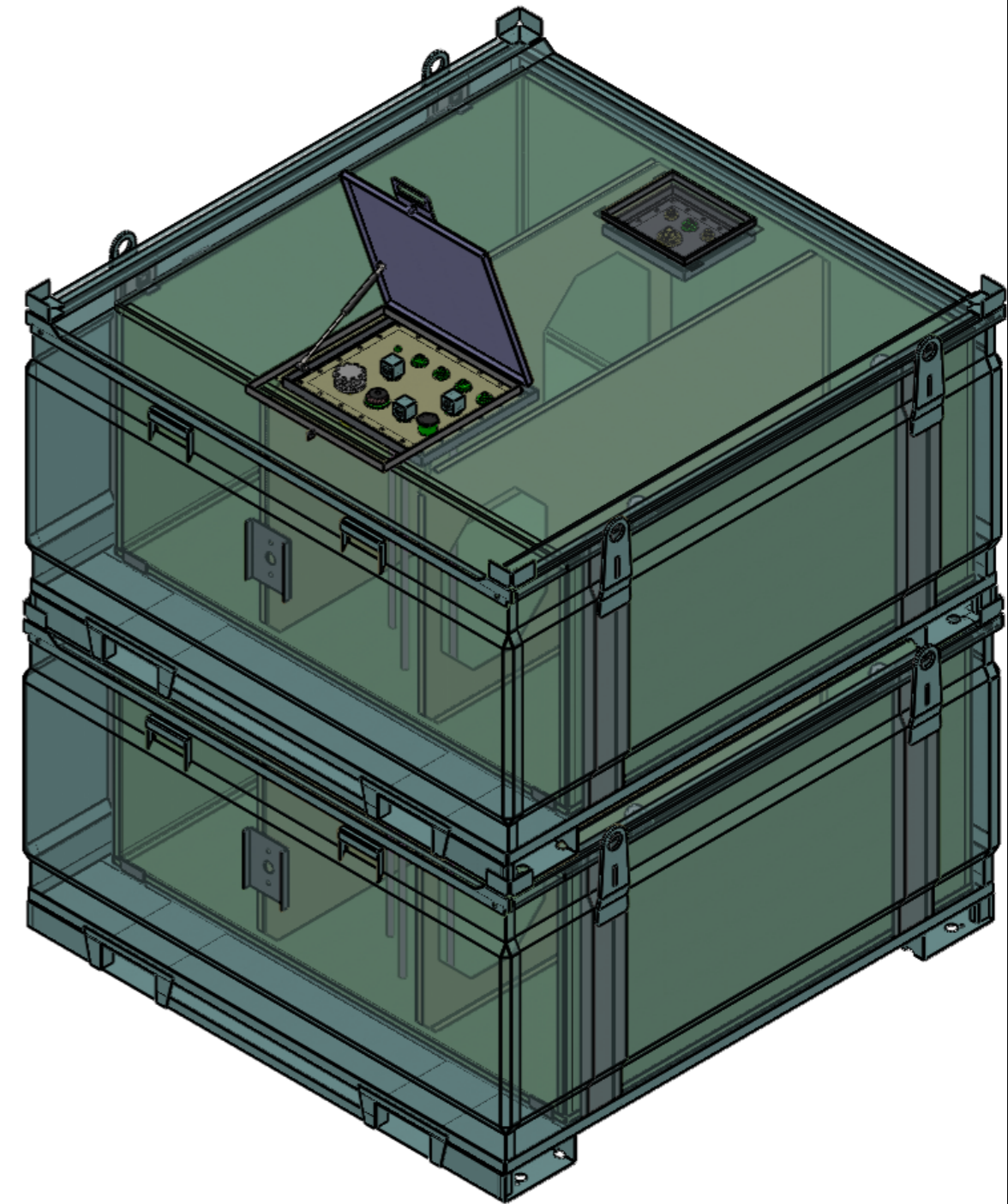
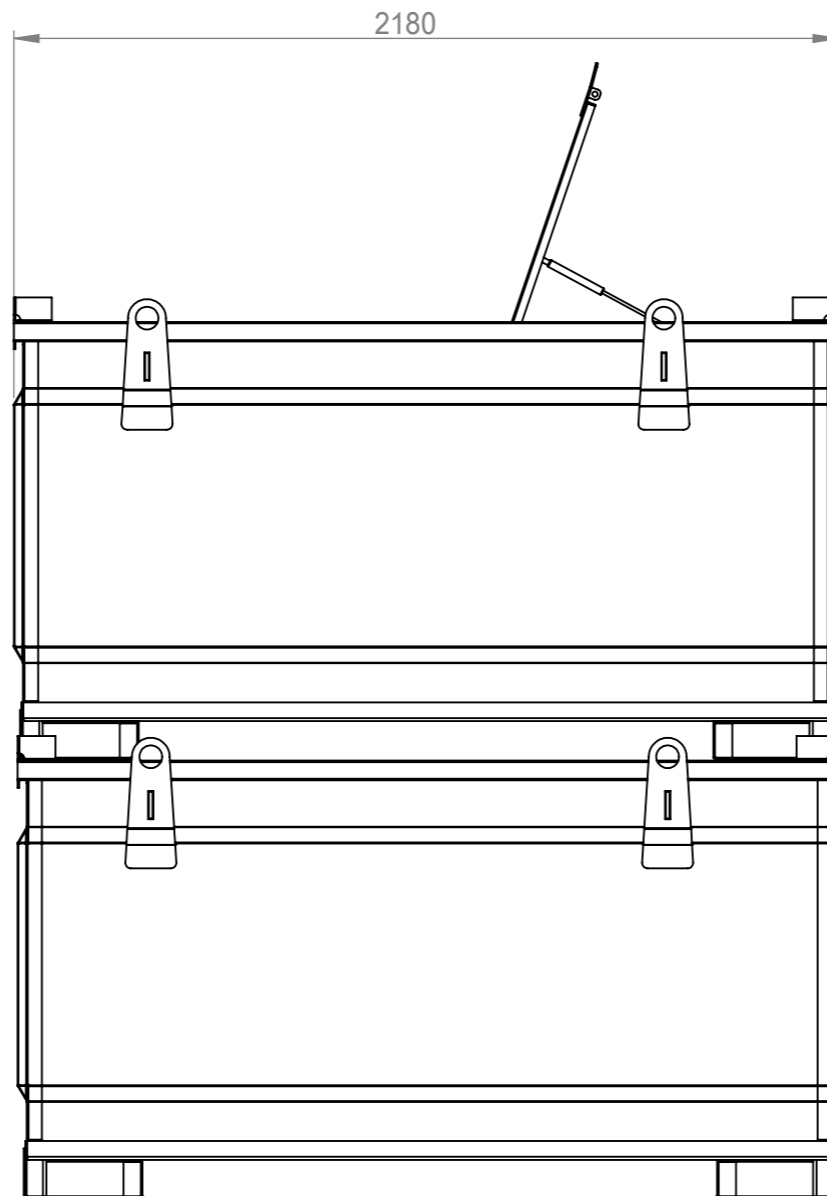
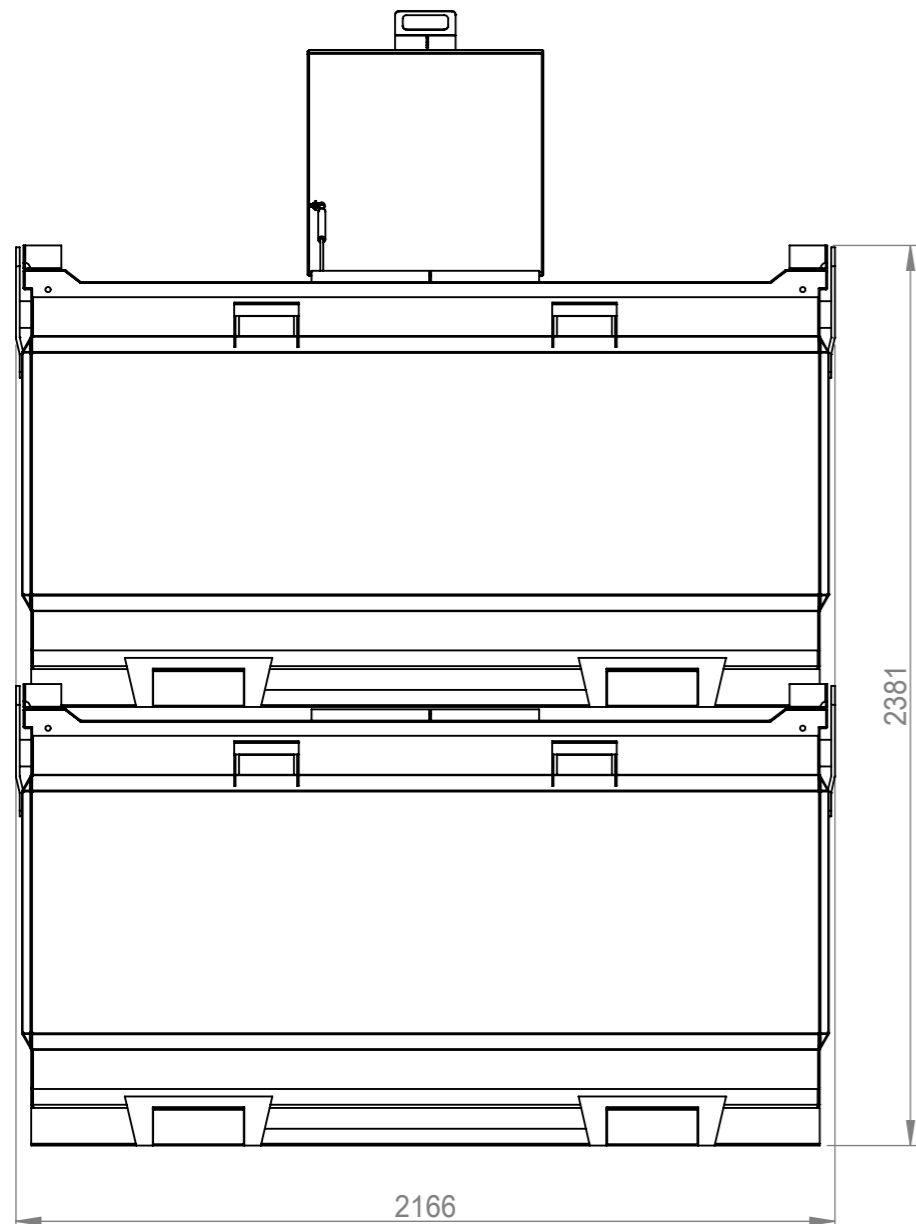

07					
06					
05					
04					
03					
02					
01					
REV:	DATE:	REVISION:	DRAWN:	CHECKED:	APPROVED:

Note:
 > Designed and approved to AS1940 / AS1692 / AS1657
 > All welding to AS1554.1



Material:
 Weight: 2211.21KG

DRAWN: DATE: 2017/6/12
 CHECKED: DATE:
 CLIENT: DATE:
 APPROVED: DATE:

TITLE:
 iFUEL 3300L Self Bunded Cube

DRAWING NO. :
 PURCHASE ORDER NO. :

REV: 01
 SHEET: 3 of 3
 Scale: No scale

A3

