

SUV DOME TENT

PACKAGING CONTENTS

TENT

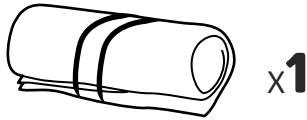

TENT POLES

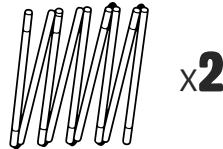

POLE BAG

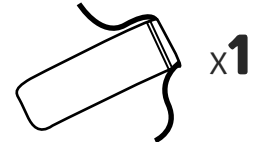

TENT BAG

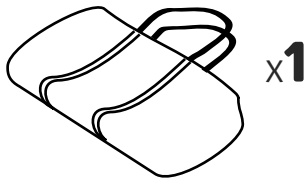

AWNING POLES

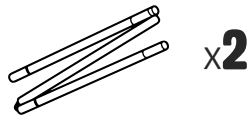

STAKE BAG

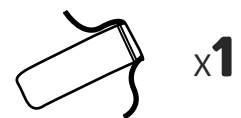

RAIN FLY

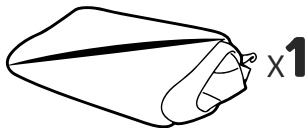

STAKES

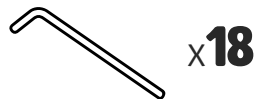

GUY LINES



YOUR TENT MAY LOOK DIFFERENT IN THE PICTURES BECAUSE PICTURES ARE FOR ILLUSTRATION PURPOSES ONLY.

SCAN THE QR CODE FOR MORE INSTALLATION INSTRUCTIONS

Need installation help? Missing parts?
Text us to (360) 215-3930 or email us to questions@offroadinggear.com.



! WARNING! NEVER RUN VEHICLE WITH THE TENT INSTALLED

Never run the vehicle with the tent installed to avoid the danger of carbon monoxide poisoning. Ensure the cargo area sleeve is installed over the exhaust pipes. Do not have the exposed exhaust pipes facing into the tent.

! WARNING!

- Keep flame and all other heat sources away from the tent fabric. The tent is made with flame-resistant fabric which meets CPAI-84 specifications but this does not make it fireproof. The fabric will burn if left in contact with any flame source. The application of any foreign substance to the tent fabric may render the flame-resistant property ineffective.
- To prevent carbon monoxide from entering the vehicle and tent area, do not run the engine, do not cook inside the tent, and do not use a gas heater in the tent. Carbon monoxide is dangerous to your health.
- Engine must be off and exhaust must be fully cooled before tent installation and use.

CAUTION

- NEVER run the engine while the tent is installed.
- Do not refuel lanterns, stoves, or heaters, inside tent.
- Do not cook inside the tent.
- Do not store flammable liquids inside the tent.
- NEVER allow the vehicle engine to run while you are inside the tent
- Do not install the tent when the outside temperature is less than 0°C/32°F as it may cause damage.
- Do not install the tent when your vehicle is wet as it may cause damage.

CHOOSING A CAMPSITE

- Select a level site clear of rocks, branches, and other hard or sharp objects, to set up your tent.
- Position the vehicle in the desired campsite. Turn off the engine and apply the parking brake.

SETTING UP THE TENT

- 1**
Position the tent with the vehicle sleeve towards the cargo area of your vehicle.

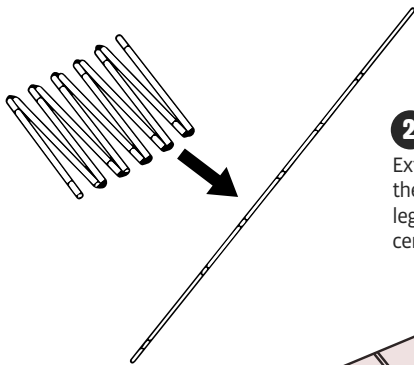
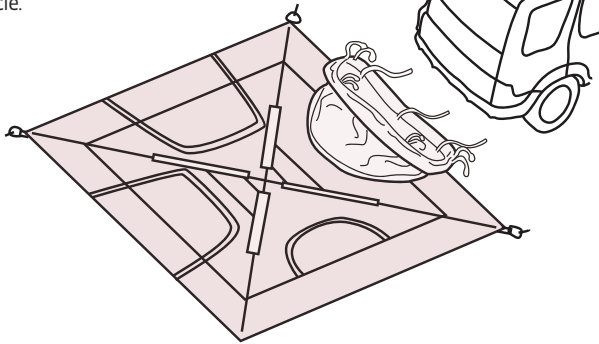

- 2**
Extend each of the four legs until they are fully locked. Once the four legs are extended, pull up on the center of the tent.

- 3**
Ensure the cam is fully locked in down position

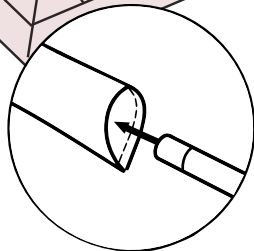

NOTE: The poles may get stuck in the pole sleeve. Do not force the pole – gently insert it to the fabric sleeve.

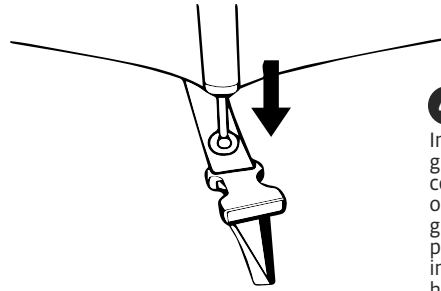

- 4**
Insert one end of the pole into the grommet hole, located in the corner of the tent. Go to the opposite end of the pole and gradually apply pressure to the pole, forming an arch, until you can insert the pin into the grommet hole.

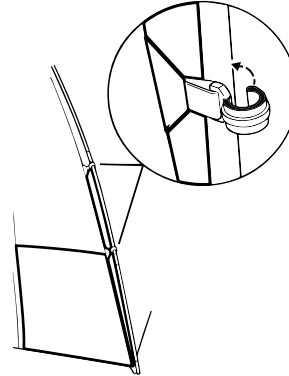

- 5**
Attach the pole clips.

- 6**
From inside of the tent, unzip the door that faces the vehicle cargo area. Roll up the mesh and door. Then secure it.

Next, open the back hatch of your vehicle.

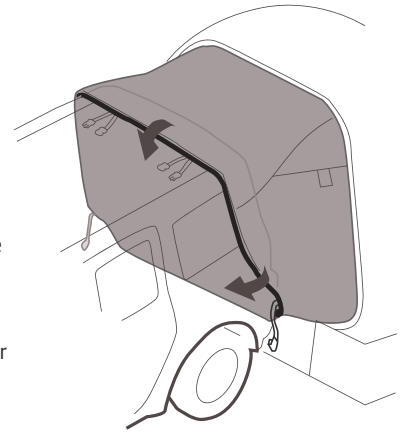

- 7**
There is an elasticized sleeve that goes around the bumper of your vehicle. Slide this around the bumper. There is also a clip on the elasticized sleeve that can be secured to the hatchback latch.

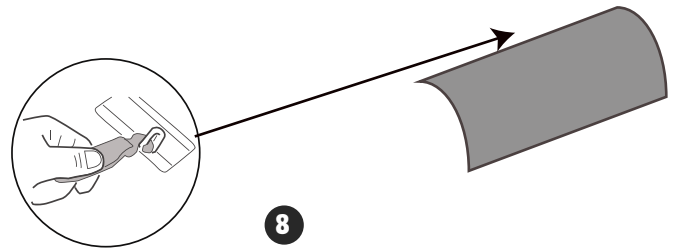

- 8**
Secure the straps behind the wheel well (one per side)

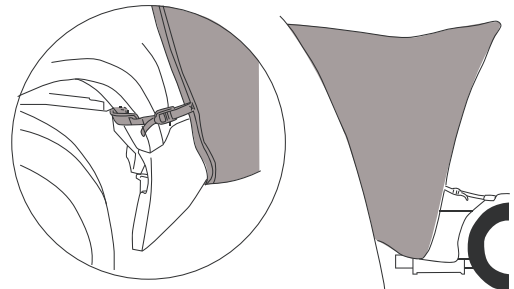

! WARNING!

Ensure the exhaust pipes are covered by the cargo area sleeve. DO NOT have the exposed exhaust pipes facing into the tent.

9 A. WITH ROOF RACK BARS

If you have a roof rack with bars, secure the top straps around the bars as shown here. Before securing the straps, you will need to remove the long strap that is attached to the female clip (this strap is not used if you have roof rack bars).

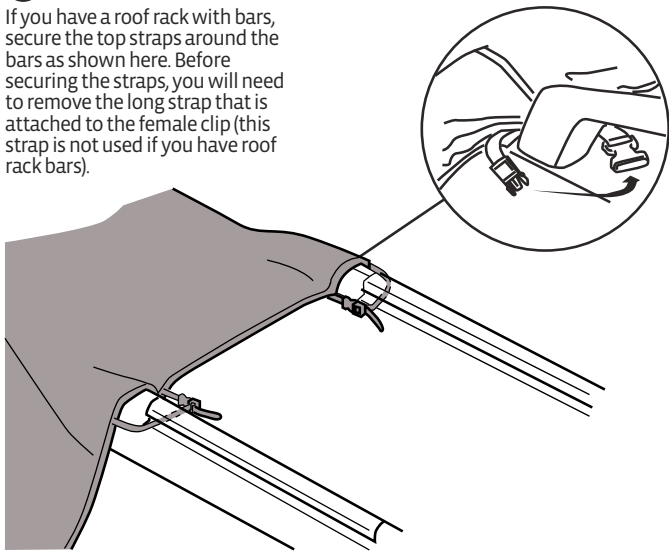

9 B. WITHOUT ROOF RACK BARS

If you do not have roof rack bars, then open the hood, and secure the straps to either the hood frame or hinges.

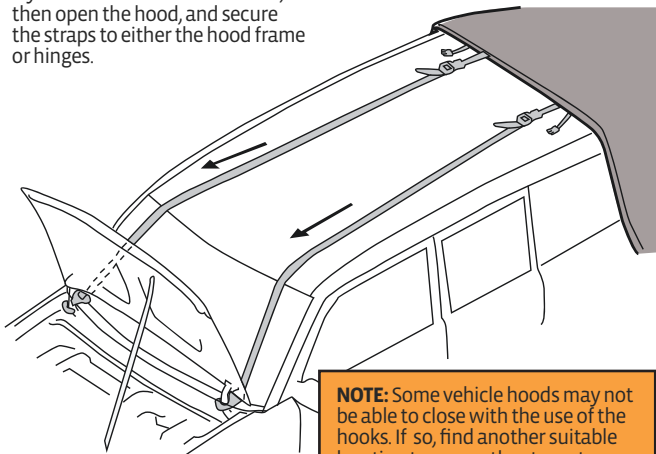

10

From inside the tent, find the center strap and attach the hook to the middle tailgate latch. Secure the two side straps to either the cargo bay area hooks or the tailgate latch.

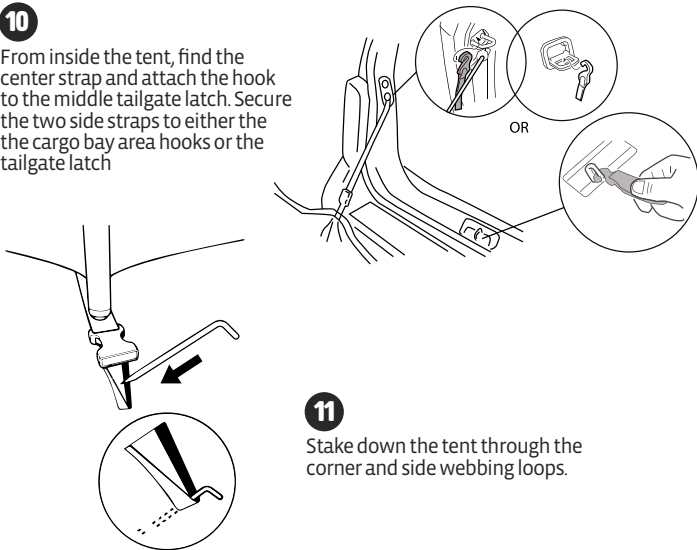

11

Stake down the tent through the corner and side webbing loops.

! WARNING!

Ensure the exhaust pipes are covered by the cargo area sleeve. DO NOT have the exposed exhaust pipes facing into the tent.

ATTACH THE RAIN FLY

12

Pull the rain fly over the tent. You can gently toss the rain fly over the top of the tent. It may help if you attach one of the guy ropes to the rain fly, and use this to help pull the rain fly over the tent.

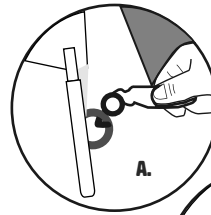

A.

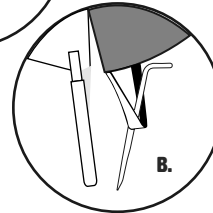

B.

13

Two options in attaching the rain fly:

A. By hooking it into the end of the inner tent's round clips at the bottom.

B. By securing it to the ground with the 4 stakes included in the package.

RAISE THE DOOR CANOPY

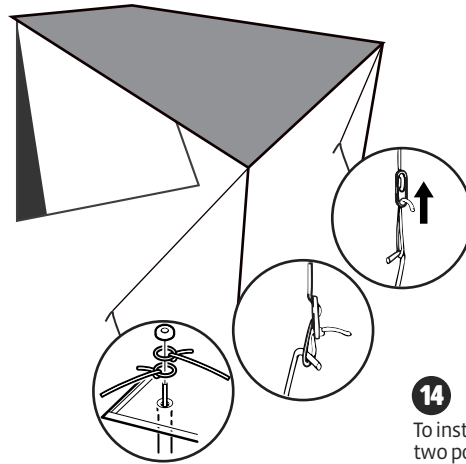

14

To install the canopy, attach the two poles to the two corners of the canopy and secure the canopy with two guy lines.

