

ETF-529

► Description

Lavatory Protective Enclosure for use with Sloan OPTIMA® Faucets. The Sloan ETF-529 Optishield™ Lavatory Enclosure conceals and protects the electronic faucet components while maintaining ADA clearance requirements. Optishield provides the proper knee and toe clearances mandated by ADA guidelines, prevents component tampering and offers the aesthetics demanded in today's commercial rest room environment.

► Specifications

- High Impact, Stain resistant, Molded Ridged Vinyl Material
- .125" (3.2 mm) Nominal Wall Thickness
- 69 - Shore A Durometer
- Fine Haircell Finish that will not fade or discolor
- Virtually indestructible
- Seven (7) Screw Fasteners with Wall Anchors provided
- China White Color
- Fits all ADA conforming 20" (508 mm) x 18" (457 mm) Wall Hung Lavatories
- UL-94 V-O Flamability Rating
- Paintable with acrylic enamel

► Features and Benefits

- **ADA conforming design protects wheelchair users from scalding and sharp surfaces.** There are no exposed lavatory plumbing, electrical and mechanical components.
- **Sleek, attractive profile is aesthetically refreshing.** Tastefully conceals all unsightly plumbing and electronic components from view and eliminates the need for piping insulation.
- **One-Size-Fits-All configuration is easy to stock and install.** May be used in virtually any new construction or retrofit 20" x 18" ADA conforming wall hung lavatory application. No assembly required; installation takes minutes using the fasteners supplied.
- **Single-piece configuration is easy to service.** May be quickly removed for any maintenance. Re-installation takes just minutes.
- **High-Impact, UV-Protected vinyl maximizes product life cycle.** Molded form impact resistant, stain-resistant, and chemical resistant. Molded Ridged vinyl for durability, safety, and long life.
- **Total Enclosure design protects lavatory components from tampering.** All piping, electronic faucet connections, mixing valves are completely concealed within this heavy-duty enclosure.
- **Strict code compliance minimizes risk.** The ETF-529 complies with ADA article 4.19.4, California P 1504B, ANSI A117.1, BOCA P 1203.4, and other state and local regulations.



EXPOSED



ENCLOSED

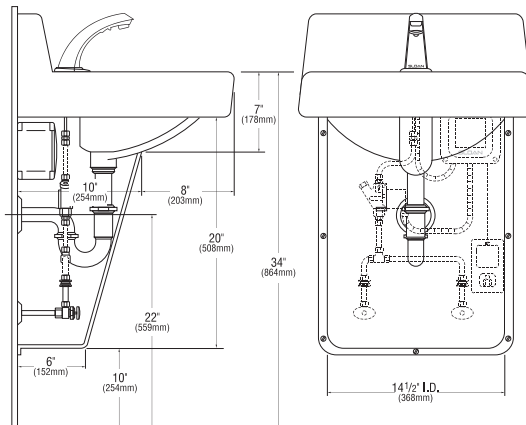

SLOAN VALVE COMPANY • 10500 SEYMOUR AVE. • FRANKLIN PARK, IL 60131
PHONE: 1-800 982-5839 • FAX: 1-800 447-8329 • <http://www.sloanvalve.com>

© Copyright 1997 SLOAN VALVE COMPANY

Made in the U.S.A.



The information contained in this document is subject to change without notice.

This space for Architect/Engineer approval

Job Name _____ Date _____

Model Specified _____ Quantity _____

Variations Specified _____

Customer/Wholesaler _____

Contractor _____

Architect _____