

► **Code Number**

3375410

► **Description**

Battery Powered, Sensor Activated Sloan ECOS® Electronic Dual Flush Model Retrofit Conversion Kit for Exposed Closet Flushometers.

► **Flush Cycle**

Full Flush (Large Button – 1.6 gpf/6.0 Lpf), Reduced Flush (Small Button – 1.1 gpf/4.2 Lpf)

► **Specifications**

Quiet, Exposed, Sloan ECOS® Electronic Dual Flush, Battery Powered, Sensor Activated Closet Flushometer Retrofit Conversion Kit for Sloan Royal®, Sloan® and Regal® Flushometers with the following features:

- Initial Set-up Range Indicator Light (first 10 minutes)
- User friendly three (3) second Flush Delay
- "Low Battery" Flashing LED
- Installation Tools provided
- Latching Solenoid Operator
- Engineered Metal Cover with replaceable Lens Window
- Courtesy Flush® Override Button
- PERMEX® Synthetic Rubber Flex Tube Diaphragm with Dual filtered bypass designed for improved life and reduced maintenance
- ADA Compliant Sloan ECOS® Electronic Battery Powered Infrared Sensor for automatic "No Hands" operation
- Infrared Sensor with Multiple-focused, Lobular Sensing Fields for high and low target detection with range adjustment screw
- Four (4) Size AA alkaline Batteries included: Duracell® with DURALOCK Power Preserve Technology™-guaranteed for up to 10 years in storage
- Diaphragm molded from PERMEX® Rubber Compound for Chloramine resistance

► **Variations**

Locking Ring for Zum® Flush Valve Bodies

► **Accessories (Sold Separately)**

See Accessories Section and Sloan ECOS® Accessories Section of the Sloan catalog for details on these and other Sloan ECOS® Electronic Dual Flush Flushometer variations.

► **Fixtures**

Consult factory for matching Sloan brand fixture options.



► **Automatic Operation**

Sloan ECOS® Flushometers can also be activated via multi-lobular infrared sensor. By detecting user presence and duration, the Sloan ECOS® Smart Sense Technology™ will determine the proper flush volume for unequalled water efficiency.

► **Manual Operation**

Sloan ECOS® Electronic Flushometers incorporate intuitive button design for easy manual activation. Straightforward graphics alert user to proper activation. The reduced flush for liquid waste or full flush for solid waste. To further educate the user, two (2) instructional wall plates are included with each Sloan ECOS® Flushometer.

► **Functional & Hygienic**

Touchless, sensor operation eliminates the need for user contact to help control the spread of infectious diseases. The Sloan ECOS® Electronic Flushometers are provided with Override Buttons to allow a "courtesy flush" for individual user comfort.

► **Patented**

D598,976

► **Compliance & Certifications**





SLOAN  
REPAIR  
.COM

TOLL FREE: 800-442-6622

[www.store.sloanrepair.com](http://www.store.sloanrepair.com)

This space for Architect/Engineer Approval

### ► ELECTRICAL SPECIFICATIONS

#### Control Circuit

- Solid State
- 6 VDC Input
- 8 Second Arming Delay
- 3 Second Flush Delay

#### Sensor Type

- Active Infrared

#### Sensor Range

- Nominal 22" - 42" (559 mm - 1067 mm), Adjustable  $\pm 8"$  (203 mm)

#### Indicator Lights

- Range Adjustment

#### Operating Pressure

- 15 - 100 psi (104 - 689 kPa)

### ► ROUGH-IN

When installing the Sloan ECOS® Electronic Dual Flush in a handicap stall: Per the ADA Guidelines (section 604.9.4) it is recommended that the grab bars be split or shifted to the wide side of the stall.

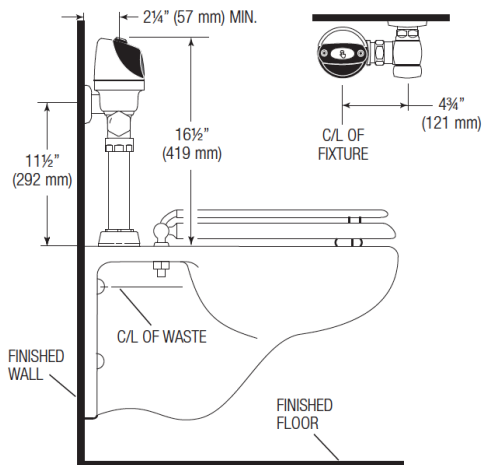

### ► OPERATION

1. A continuous, invisible light beam is emitted from the Sloan ECOS® Flush Sensor.

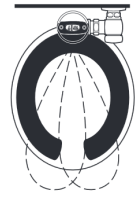

2. As the user enters the beam's effective range, 22" to 42" (559 mm to 1067 mm), the beam is reflected into the Scanner Window to activate the Output Circuit. Once activated, the Output Circuit continues in a "hold" mode for as long as the user remains within the effective range of the sensor. If the user stays longer than 65 seconds, a full flush will automatically initiate when the user leaves.

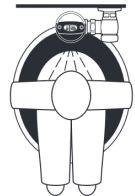

3. Once a user is detected, if the user leaves in 65 seconds or less, a reduced flush will automatically initiate. The circuit automatically resets and is ready for the next user.

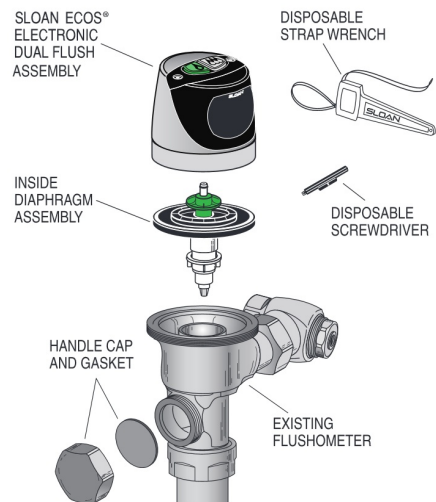
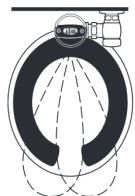

RESS-C units do NOT include a Valve Body, Supply Stop or Vacuum Breaker.



SLOAN  
REPAIR  
.COM

TOLL FREE: 800-442-6622

[www.store.sloanrepair.com](http://www.store.sloanrepair.com)