

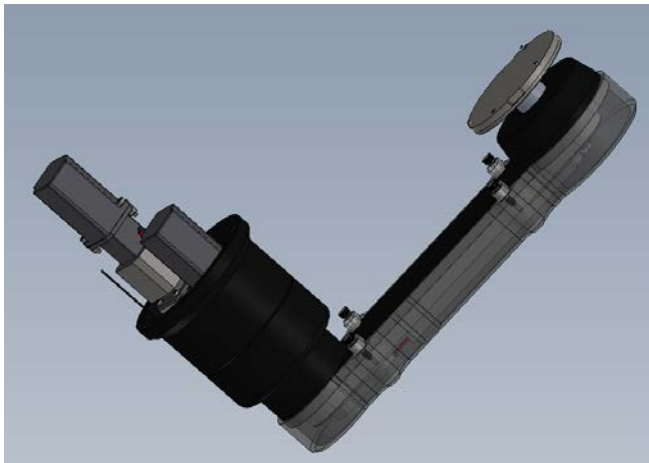

Pad Conditioner Teflon Coating

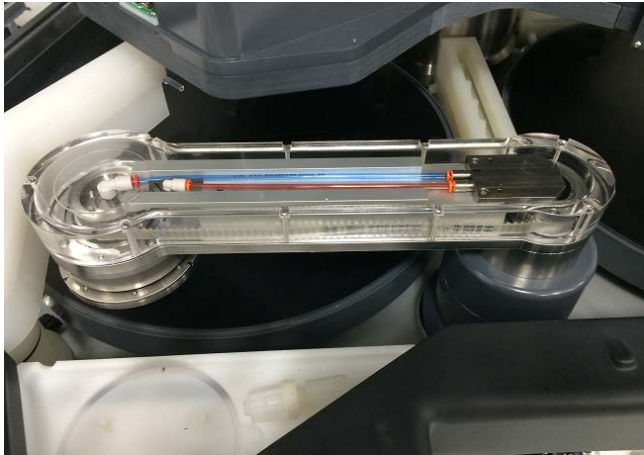

Overview

The Mirra Pad Conditioner assembly is located next to the CMP processing platen where it's subject to chemical and process waste material. This material builds up on the assembly and must be cleaned during preventative maintenance intervals. The cleaning of this process waste requires additional time and often causes additional particle generation. Super-slick Teflon coating of the Pad Conditioner significantly reduces the build up of waste material, making cleaning as simple as rinsing the assembly.

Service

The customer provides their complete pad conditioner core. Entrepix will have the parts stripped of the OEM grey paint. All underside surfaces will be masked then coated with chemical resistive primer and super slick black Teflon.

Service Options

- Entrepix Clear Pad Conditioner Arm Cover - fits along side the arm and makes servicing easy with only four fasteners.
- If Teflon coating the entire assembly is not desired, coating of hub, arm, or head separately is available





To Find Out More Or To Place An Order See Our Links Below.

To see more part details on the pad conditioner Teflon coating service click the our video icon.



To email Entrepix parts or to get additional parts information click icon.



To explore, shop and download part information click icon.



To call Entrepix parts dial or click. icon

