

12V C.C. - D.C.

VA22-AP11/C-50A
VA22-AP11/C-50S

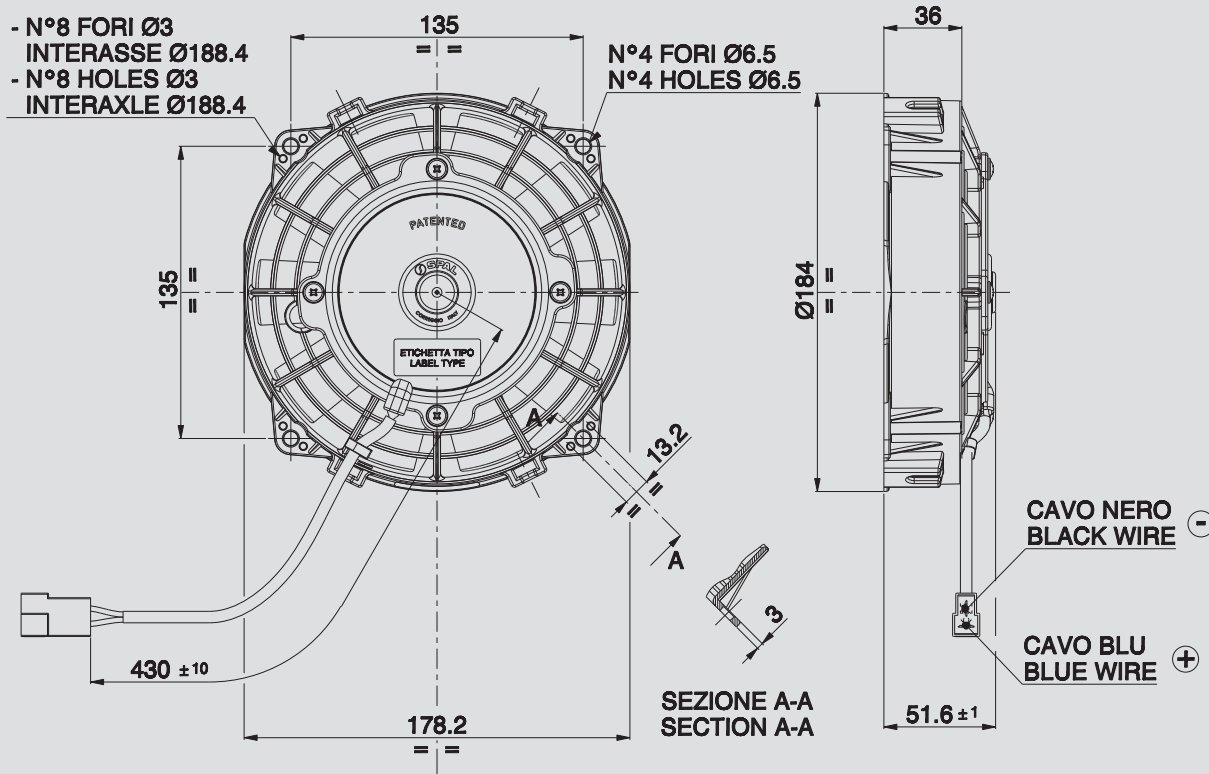

AMP connector Code 180908
AMP terminal Code 42098-2
Suggested mounting torque: 3(+1/-0) Nm with screw M5
Weight 0,80 Kg. approx.

Connettore AMP Cod. 180908
Terminali AMP Cod. 42098-2
Coppia di serraggio consigliata: 3(+1/-0) Nm con vite M5
Peso 0,80 Kg. circa

Ø 167 mm

Ø 6,5"

suction / aspirante

blowing / soffiante

PRODUCT FEATURES
CARATTERISTICHE PRODOTTO

Static pressure Pressione statica mm H ₂ O	suction / aspirante			blowing / soffiante			Static pressure Pressione statica inH ₂ O
	Airflow Portata m ³ /h	Current input Corrente assorbita A	Airflow Portata CFM	Airflow Portata m ³ /h	Current input Corrente assorbita A	Airflow Portata CFM	
0	530	5,0	313	510	5,1	301	0
2,5	490	5,4	289	480	5,4	283	0,1
5	460	5,3	271	430	5,2	254	0,2
7,5	430	5,5	254	410	5,3	242	0,3
10	370	5,6	218	320	5,4	189	0,4
12,5	330	5,5	195	250	5,2	148	0,5
15	290	5,3	171	190	5,6	112	0,6
20	220	5,6	130	140	5,7	83	0,8
25	130	5,8	77	0	6,1	0	1
30	0	5,9	0				

Waterproof motor, IP 68
Motore chiuso, IP 68



Long life / Lunga durata



LL and VLL version*
Versione LL e VLL*



Waterproof connector
Connettori a tenuta stagna



Accessories: all the fixing kits
Accessori: tutti i kit di fissaggio



* for OEM applications only.
* per applicazioni OEM

✓ = Standard feature
Caratteristiche standard

✓ = Available upon request
Disponibile su richiesta

Test voltage 13 V. d.c. - Tensione di prova 13 V. c.c.