

**DEALERS MUST TRANSLATE THEIR OWN LANGUAGE OF  
MANUAL INSTRUCTIONS BELOW FOR YOUR MARKET  
PLEASE READ THE INSTRUCTIONS  
CAREFULLY BEFORE USE**

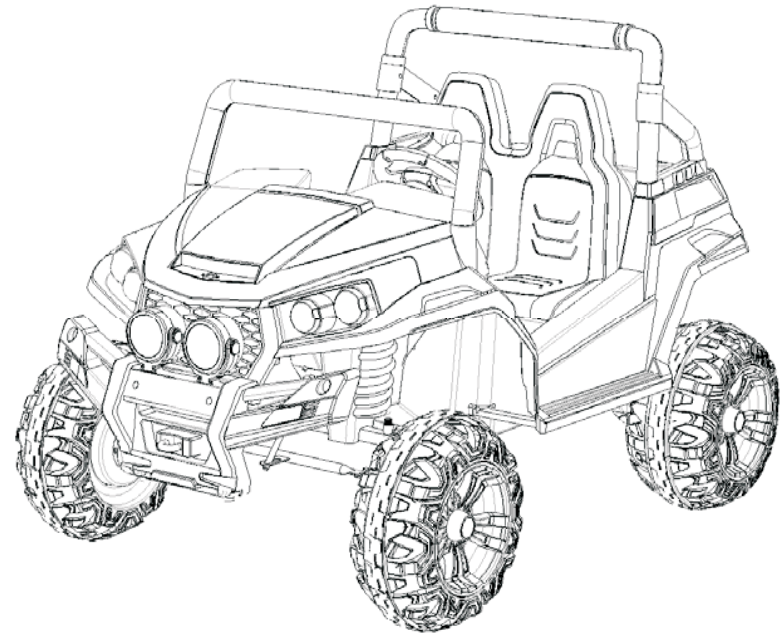

**Styles and colors may vary**

**Keep the package away from children and dispose of  
properly before use**

## 1.Specification:

Motor	2 *45W	4 *45W
Battery	12V7AH*1	12V10AH*1
Charger	12V1000MA	12V1000MA
Speed	3km/hr	3-5km/hr

Suitable age : 37-96 months

Load Capacity: Under 30KGS

Size of car: 135×93×93CM

Power way: Charging type

Charge time : 8-12 hours

## 2.Packing list:

Number	Name	Quantity
1	Seat	1
2	Steering wheel	1
3	wheel	4
4	Wheel cap	4
5	wheel trim part	4
6	Front bumper	1
7	Rear axle	1
8	Rear drive motor	2
9	Rear handrail	1
10	Front handrail	1
11	Remote control	1
12	charger	1
13	Spanner	2
A	Ø12 gasket	4-6
B	M10 nut	4-5
C	M5×37 screw	1
D	M5 nut	1
E	Ø4×10 screw	8-9

- Make sure the plastic parts of the vehicle are not cracked or broken.
- Occasionally use a lightweight oil to lubricate moving parts such as wheels.
- Park the vehicle indoors or cover it with a tarp to protect it from wet weather.
- Keep the vehicle away from sources of heat, such as stoves and heaters. Plastic parts may melt.
- Recharge the battery after each use. Only an adult can handle the battery. Recharge the battery at least once a month when the vehicle Raider is not being used.
- Do not wash the vehicle with a hose. Do not wash the vehicle with soap and water. Do not drive the vehicle in rainy or snowy weather. Water will damage the motor, electric system and battery.
- Clean the vehicle with a soft, dry cloth. To restore shine to plastic parts, use a non-wax furniture polish. Do not use car wax. Do not use abrasive cleaners.
- Do not drive the vehicle in loose dirt, sand or fine gravel which could damage moving parts, motors or the electric system.
- When not using, all the electrical source should be turn off. Turn off the power switch and disconnect the battery connection.

### 3. Parts Diagram

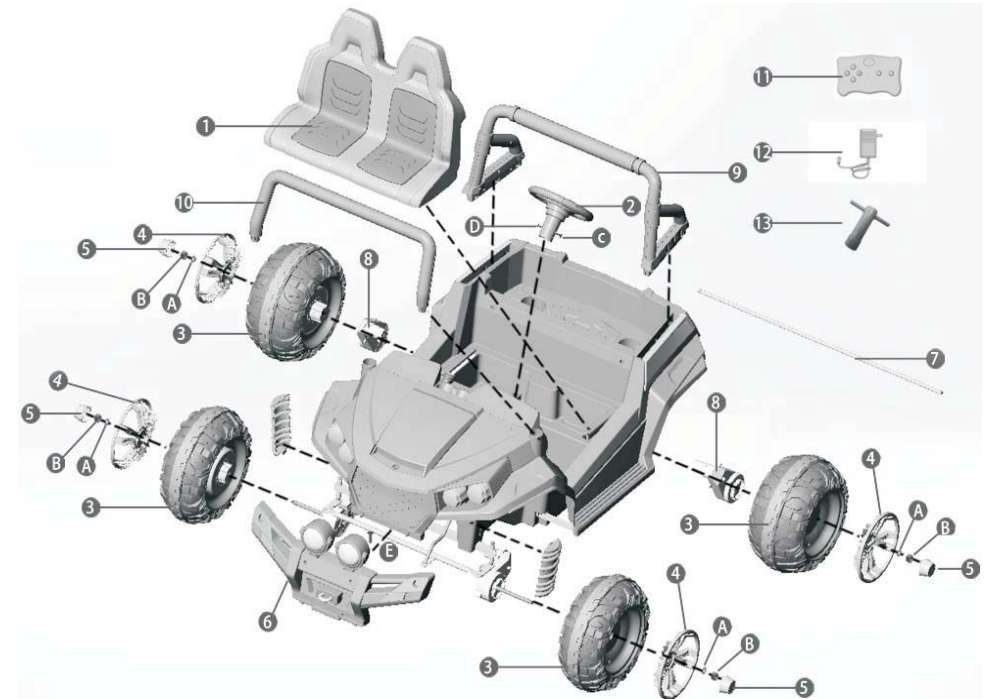

#### **WARNING!**

FOR THE SAFETY OF YOUR CHILDREN , PLEASE READ ALL WARNINGS AND ASSEMBLY/USE INSTRUCTIONS.KEEP THIS GUIDE FOR FUTURE REFERENCE.

- ADULT ASSEMBLY REQUIRED. The product contains small parts, which are for adult assembly only. Keep children away when assembling.
- Always remove protective material and poly bags and dispose before assembly.

#### **Assembly tools required:**

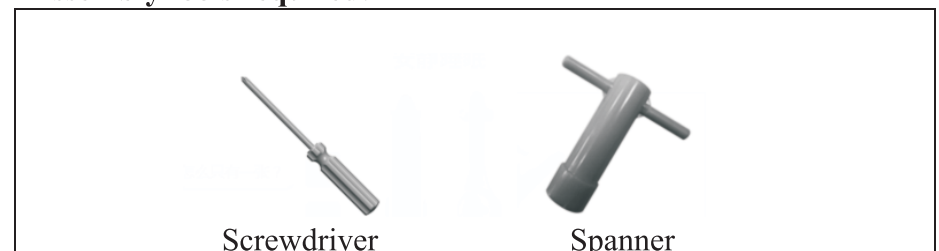

Screwdriver

Spanner

Vehicle needs a push to go forward	Poor contact of wires or connectors	Check that the battery connectors are firmly plugged into each other. If wires are loose around the motor, <b>contact your distributor please.</b>
	“Dead Spot” on motor	A dead spot means the electric power is not being delivered to the terminal connection and the vehicle needs repair. <b>Contact your distributor please.</b>
Loud grinding or clicking noises coming from motor or gear box	Motor or gears are damaged	<b>Contact your distributor please.</b>
Battery with not recharge	Battery connector adapter connector is loose	Check that the battery connectors are firmly plugged into each other.
	Charger not plugged in	Check that the battery charge is plugged into a working wall outlet.
	Charger is not working	<b>Contact your distributor please.</b>
Charger feels warm when recharging	This is normal and not a cause for concern	

Completely read through this manual and the troubleshooting guide table before calling. If you still need help resolving the problem **Contact your distributor please.**

## 10.Maintaining

- It is parents’ responsibility to check main parts of the toy before using, Must regularly examine for potential hazard, such as the battery, charge, cable or cord, plug, screws are fastening enclosure of other parts and that in the event of such damage, the toy must not be until that damage had been properly removed.

## 4.Operation Instruction:

### (A) Install Front bumper and wheel (2 Motors)

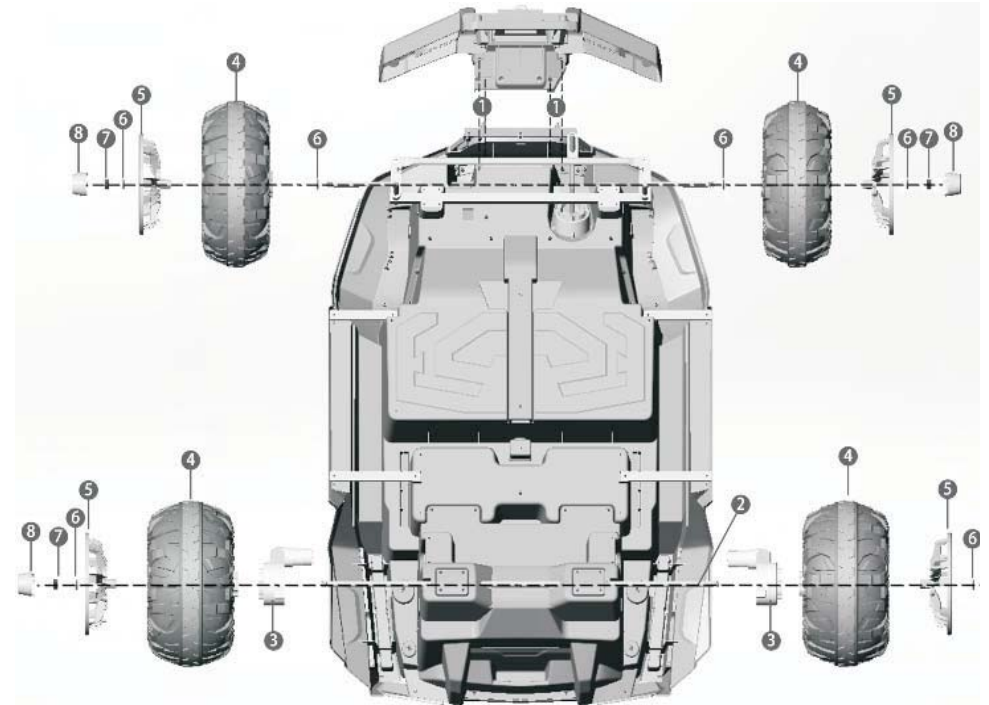

- 1) Install the front bumper with  $\varnothing 4 \times 10$  screw ,fix it to the main body of the car.
- 2) Fix the rear axle to the car body, keep the left and right side same
- 3) Put the Rear drive motor to the rear axle
- 4) Put  $\varnothing 12$  gasket to the front axle then install the front wheel. Install the back wheel to the rear axle.
- 5) Put the Wheel caps onto the wheels
- 6) Put one pcs of  $\varnothing 12$  gasket to every axles
- 7) Fixed the M10 nut to the axle with Spanner
- 8) Put the wheel trim part to the 4 wheels

#### NOTE:

In order to prevent the wheel from shrinking, the user will decide whether to increase the gasket to adjust.

illegal in most areas to incinerate lead acid batteries or dispose of them in landfills. Take it to a federal or state-approved lead acid battery recycler, such as local automotive battery retailer.

Do not throw the battery away with your regular household waste!

7. Replace the battery and reconnect the connectors.
8. Replace the metal battery bracket.
9. Replace the seat.

## 9. Troubleshooting Guide

Problem	Possible Cause	Solution
Vehicle dose not run	Battery low on power	Recharge battery
	Fuse has broken	Replace, see <Fuse>
	Battery connector or wires are loose	Check that battery connectors are firmly plugged into each other. If wires are loose around the motor <b>contact your distributor please</b>
	Battery is dead	Replace battery , <b>contact your distributor please</b>
	Electrical system is damaged	<b>Contact your distributor please</b>
Vehicle dose not run very long	Motor is damaged	<b>Contact your distributor please</b>
	Batter is under charged	Check that the battery connectors are firmly plugged into each other when recharging
Vehicle runs sluggishly	Battery is old	Replace battery, <b>contact your distributor please.</b>
	Battery low on power	Recharge battery, <b>contact your distributor please.</b>
	Battery is old	Recharge battery, <b>contact your distributor please.</b>
	Vehicle is overload	Reduce weight on vehicle. Maximum user weight is 30 kgs.
Vehicle is being used in harsh conditions	Avoid using vehicle in harsh conditions, see <safety>	

## (B) Install Front bumper and wheel (4 Motors)

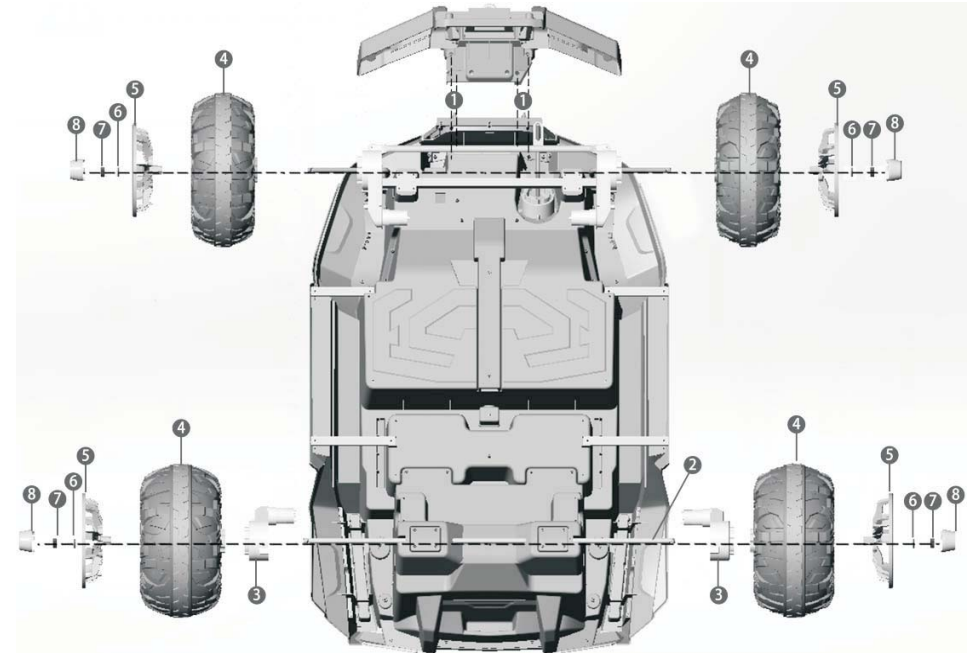

Please according the Operation Instruction 1-3 / 5-8

4. Put Ø12 gasket only to rear axle. Install the wheel to the axle. (The wheel need match the gear box)

## C: Install the seat

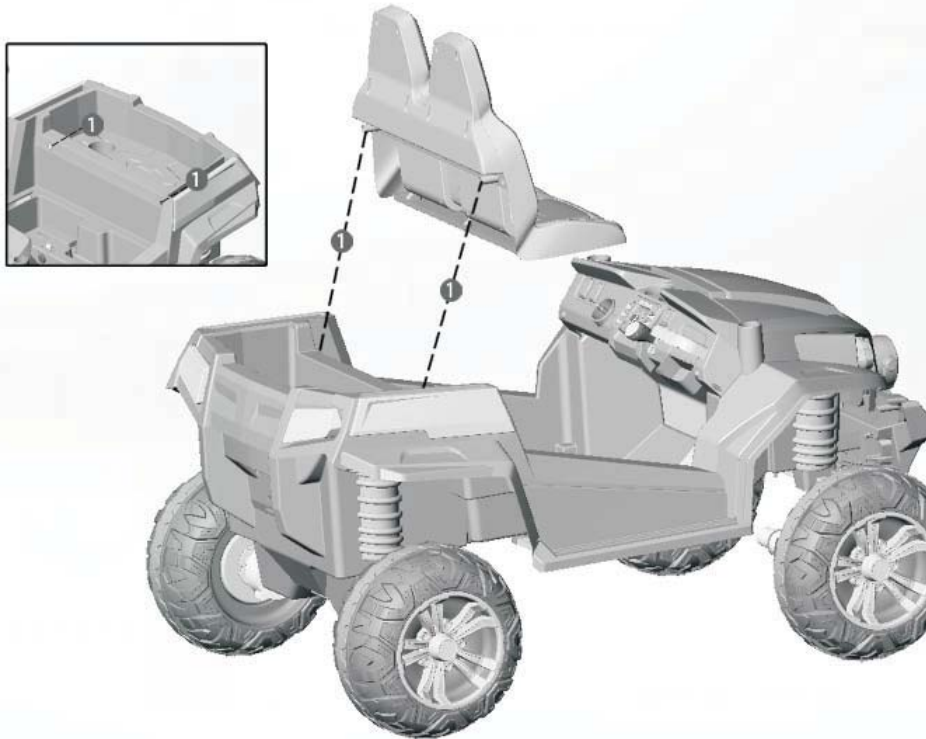

Slide the seat to the slot until the metal into the hole of the car body

seat or behind the body of the car. Replace and restart.

To avoid losing power , follow these guidelines:

- Do not overload the vehicle.
- Do not tow anything behind the vehicle.
- Do not drive up steep slopes.
- Do not drive into fixed objects, which may cause the wheels to spin, causing the motor to overheat.
- Do not drive in very hot weather, components may overheat.
- Do not allow water or other liquid to come in contact with the battery or other electric components.
- Do not tamper with the electric system. Doing so many create a short , causing the fuse to trip.

## Battery Replacement and Disposal

The battery will eventually lose the ability to hold a charge . Depending on the amount of use , and varying conditions, the battery should operate for one to three years. Follow these steps to replace an dispose the battery:

1. Remove the car seat .
2. Disconnect the battery connectors.
3. Remove the metal battery bracket.
4. Remove the battery cover
5. Carefully lift the battery
  - Depending on the condition of the battery (i.e.: leakage) you may want to wear protective gloves before removal.
  - Do not lift the battery by its connectors or cables
6. Place the dead battery in a plastic bag.

**Important!** Recycle the dead battery responsibly. The battery contain lead(electrolyte ) and must be disposed of properly and legally. It is

NEVER pick up the battery by the wires or charger. Damage can occur to the battery and may cause a fire. Pick up the battery by the case ONLY.

- Charge the battery in a dry area ONLY.

- Battery posts, terminals and related accessories contain lead and lead compounds, chemicals known to the State of California to cause cancer and reproductive harm. **Wash hands after handling.**
- Do not open the battery. Battery contains lead acid and other materials that are toxic and corrosive.
- Do not open the charger. Exposed wiring and circuitry inside case electric shock.. Only adults may handle or charge the batter. NEVER allow child to handle or charge the battery. Battery is heavy and contains lead acid (electrolyte).
- Do not drop the battery. Permanent damage to the battery could occur or cause serious injury.
- Before charging the battery, check for wear or damage to the battery, charger, its supply cord and the connectors. DO NOT charge the battery if any damage to parts has occurred.
- Do not allow the battery to drain completely. Recharge the battery after each use or once a month if not used regularly.
- Do not charge battery upside down.
- Always secure the battery with bracket, Battery can fall out and injure a child if vehicle tips over.
  
- The POWER SWITCH must be turned in OFF position when charging.
- Before the first use, you should charge the battery for 4-6 hours. Do not recharge the battery for more than 10 hours to avoid overheating the charger.
- When the vehicle begins to run slowly, recharge the battery.
- After each use or once a month minimum recharge times as 8 to 12 hours, less than 20 hours at most.

## 8. Battery Replacement & Fuse

If the fuse is broken, there has a spare fuse in the fuse box under the

## D. Install the steering wheel

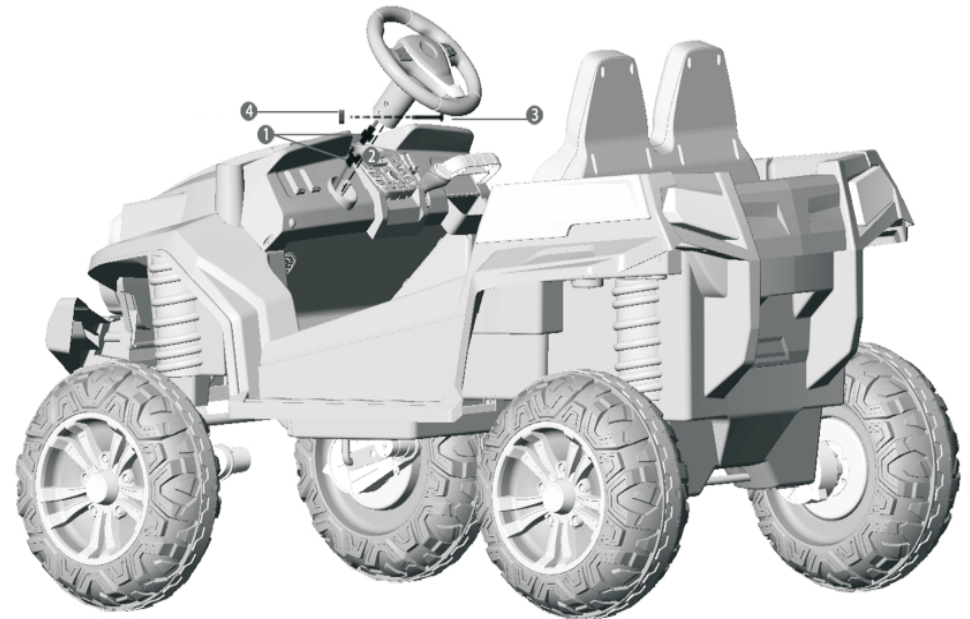

1. Connect the music wire to the steering wheel
2. Install the steering wheel on the steering shaft .Align the hole from the steering wheel and steering shaft
3. Fixed it with screw M5×37
4. Put on the nut M5

## E: Install the handrail



1. Insert the Rear handrail into the corresponding slot to make it stuck in and fixed
2. Same way to Front handrail



## 7.Charging

**ONLY AN ADULT CAN CHARGE AND RECHARGE THE BATTERY!**

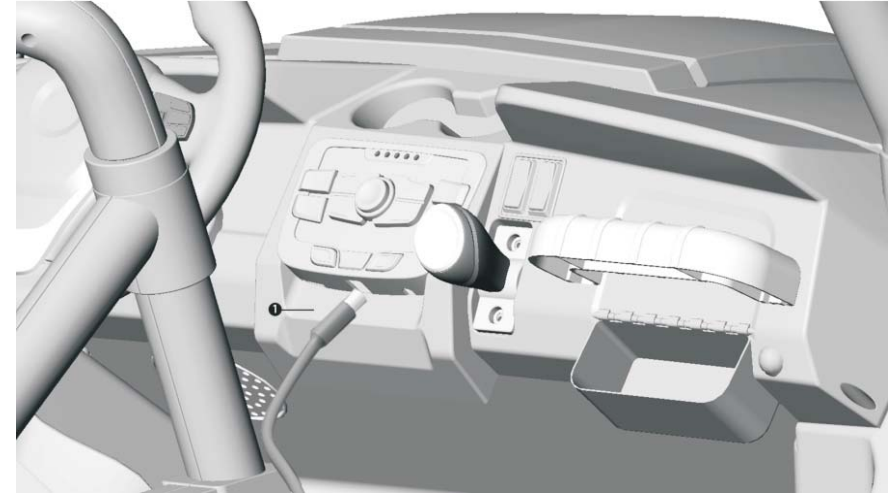
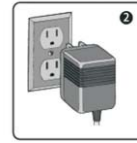

### **WARNING!**

#### ● **PREVENT FIRE AND ELECTRIC SHOCK:**

- Use the only rechargeable battery and charger supplied with your vehicle. NEVER substitute the battery or charger with another brand. Using another battery or charger may cause a fire or explosion.
- Do not use the battery or charger for any other product. Overheating, fire or explosion could occur.
- NEVER modify the electric circuit system.. Tampering with the electric system may cause a shock, fire or explosion or may permanently damage the system.
- Do not allow direct contact between battery terminals. Fire or explosion can occur.
- Do not allow any type of liquid on the battery or its components.
- Explosive gasses are created during charging. Do not charge near or flammable materials. Charge the battery in a well-ventilated area ONLY.



## 6. Safety

### **WARNING!**

#### PREVENT INJURIES AND DEATHS:

- **NEVER LEAVE CHILD UNATTENDED. DIRECT ADULT SUPERVISION REQUIRED.** Always keep child in view when child is in vehicle.
- This toy should be used with caution since skill is required to avoid collisions causing injury to the user or third parties.
- Protective equipment should be worn.
- Never use in roadways, near cars, on or near steep inclines or steps swimming pools or other bodies of water.
- Always wear shoes.
- Always sit on the seat.
- Not to be used in traffic.
- This toy is unsuitable for children under 37 months due to its maximum speed; Maximum user weight is 30 kgs.
- This toy has no brake.

#### Rules for Safe Riding

- Keep Children within safe riding areas:

Never use in roadway, near motor vehicles, on lawn space, on or near steep inclines or steps swimming pools or other bodies of water;

Use the toy only on flat surfaces. Such as inside your house, garden or playground

- Never use in the dark. A child could encounter unexpected obstacles and have an accident. Operate the vehicles only in the daytime or well-lit area.
- It is prohibited to change the circuit or add other electric parts.
- Inspect wires and connections of the vehicle periodically
- Do not let any child touch the wheels or be near them when the car is moving.

## F: Power Connecting



1. Turn the Buckle on the front engine cover to unlocking position
2. Connecting the terminal on battery, choose the same shape and color

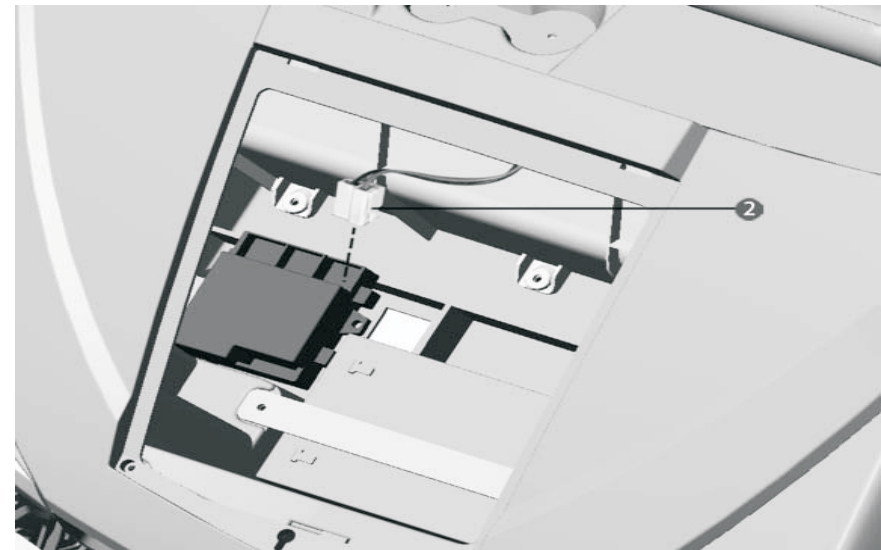

## G: Function introduction

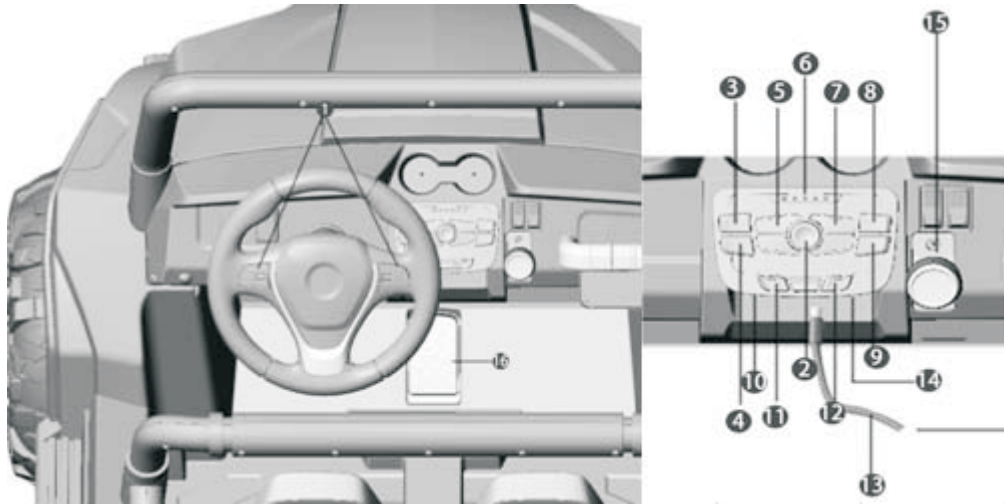

- 1.Sound button: Press it for sounds or music playing
- 2 Power Button: Turn the vehicle on and off
- 3Last song: Switch songs, and long press will increase volume
- 4next song: Switch songs, and long press will decrease
- 5 Stop playing button: Press the button to open the music ,or stop
- 6Power display: Clearly see the battery power, in order to charger in time
- 7Music Button: Play music
- 8.Bluetooth Speaker: Content the mobile phones and Bluetooth, then the car  
Can play the music
- 9 FM: Radio
- 10 Mp3 slot
- 11 NO USE
- 12 Light button : Turn on or off the light
- 13 Socket : Charge
- 14 TF Slot
- 15.Shift Switch: Change the direction of the car , Forward-Backward
- 16.Pedal: Press , the car will move when the power on

## 5. Operation manual of 2.4G Remote Control

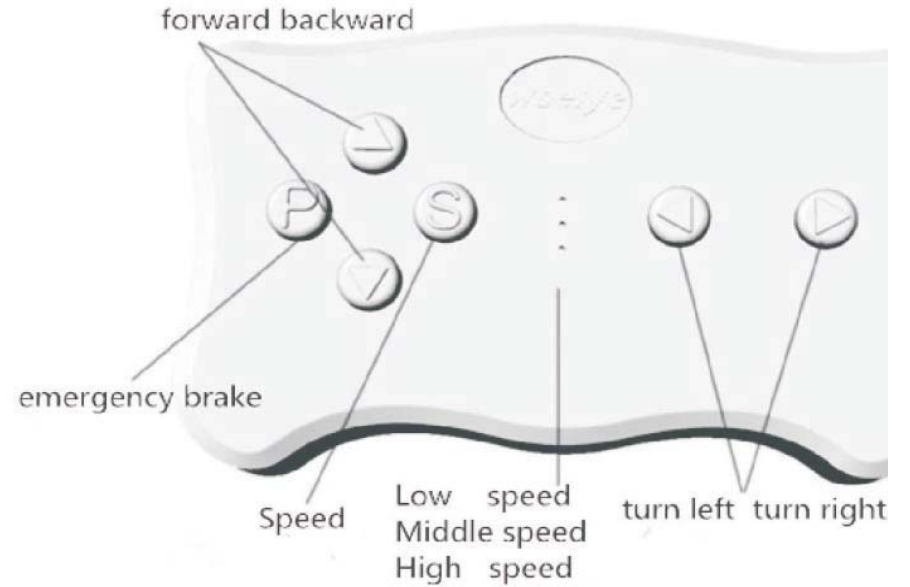

### This product has remote control priority

#### NOTE:

This product does not included the AAA(1.5V) battery

Only allow adult to use the remote control ,can't let the children touch  
Operation Manual : For the first time to use (Or Replace the battery)Need to frequency bind

- Take out the remote control, install the battery
- Long press on the frequency key(in the middle of the Remote control) 2-4 seconds, Low speed LED light flashing
- Turn on the power of the car, Low speed LED light keep flashing to long lighting, then frequency bind succeed
- If the frequency bind failed (Low speed LED light flashing) , remove the battery and repeat steps 1~3
- remote control without operation after 10 seconds, indication light will off into power saving mode
- Button Description:  $\triangle$  forward  $\nabla$  backward  $\triangleleft$  turn left  $\triangleright$  turn right  
S: Speed , P: emergency brake, Press it and the running function will fail, press again, it release