

MOTOWORKS AUSTRALIA

125CC FARM

Read this manual carefully. It contains important safety information. Children under the age of 16 should be supervised by a responsible adult.

OWNER'S MANUAL



ATV Category T

Minimum Age Requirement: 16

Transitional Model that is intended for recreational use by an operator age 14 or older under adult supervision, or by an operator age 16 or older.



Always wear a helmet; It could save your Life!

Please obtain, review, and follow provincial / municipal government acts and regulations pertaining to owning and operating an off-road vehicle.

WARNING

YOUR ATV CAN BE HAZARDOUS TO OPERATE

A collision or rollover can occur quickly, even during routine maneuvers such as turning and driving on hills or over obstacles, if you fail to take proper precautions.

For your safety, understand and follow all the warnings contained in this owner's manual and the labels on your vehicle. Failure to follow these warning can result in **sever injury or death**.

FOLLOW THE AGE RECOMMENDATIONS

Use by children of ATVs that are not recommended for their age can lead to severe injury or death. Even though a child may be within the age group for which an ATV is recommended, he or she may not have the skills, abilities, or judgement needed to operate the ATV safely and may be involved in a serious accident.

Category Y (Youth Model) ATV

An ATV of appropriate size intended for recreational use under adult supervision by an operator under age 16. Youth model ATVs can further be categorized as follows:

ATV Category Y- 6+: The ATV is intended for use by children age 6 or older.

ATV Category Y-10+: The ATV is intended for use by children age 10 or older.

ATV Category Y-12+: The ATV is intended for use by children age 12 or older.

ATV Category T: Transitional Model that is intended for recreational use by an operator age 14 or older under adult supervision, or by an operator age 16 or older.

This manual should be considered as a permanent part of the vehicle and should remain with the vehicle when resold or otherwise transferred to a new user or operator. The manual contains important safety information and instructions which should be read carefully before operating the vehicle.

TABLE OF CONTENT

SAFETY	01
MOTOWORKS 125CC FARM	04
LOCATION OF LABELS	06
CONTROL FUNCTIONS	08
RIDING YOUR ATV	10
INSPECTION AND MAINTENANCE	19
TROUBLESHOOTING	28
TRANSPORTING	29
CLEANING & STORAGE	30
WIRING DIAGRAM	32
WARRANTY & LIABILITY	33
Evaluation Sheet	35
Pre-delivery Certificate	36

Manufacturer:
WUYI QIAOWEI ELECTRICAL
VEHICEL CO., LTD
Hardware Machinery Industrial Zone,
Wuyi Country, Zhejiang, China MADE IN
CHINA

Imported By:
Motoworks Australia
18B Humeside Drive
Campbellfield, VIC, 3061
Tel: 03 9357 5133
www.motoworks.com.au

SAFETY

NOTICE TO PARENTS

This ATV is built for use by children age 16 and older, but the users manual is written for adults who will be supervising the children, we strongly recommend, therefore, that you review this entire manual with your child and carefully explain the instructions, requirements, and warnings it contains so that your child can understand them.

Children differ in skills, physical abilities, and judgement. Some children may not be able to operate an ATV safely.

Refer to the **Evaluation Sheet** provided at end of the manual.

THIS ATV IS NOT A TOY AND COULD BE HAZARDOUS TO OPERATER

An ATV handles differently from other vehicles including motorcycles and cars.

A collision or rollover can occur quickly, even during routine maneuvers such as turning and driving on hills or over obstacles, if you fail to take proper precautions.

USE THE MANUAL

Please read this manual and follow all instruction carefully. To emphasize the specail information. Pay great attention to **WARNING** or **CAUTION**.

▲ WARNING

Indicates a potential hazard that could result in death or injury

▲ CAUTION

Indicates a potential harzard that could result in vehicle damage

▲ WARNING - or - CAUTION

Identify a potential hazard
Describe what cloud happen if you ignore the WARNING or CAUTION How to avoid the hazard

All information, illustrations, photographs and specifications contained in this manual are absed on the lastest procdt information available at the time of publication. due to improvements or other changes, there will be some discrepancies in this manual. we reserve the right to make product changes at any time without incurring any obligation to make the same or similar changes to the vehicle previously built or sold.

This product comply with Consumer Goods (Quad Bikes) Safety Standard 2019 Under Category Y (Youth Model) ATV Y-16+

SAFETY

SEVERE INJURY OR DEATH can result if you do not follow these instructions:

- Read this manual and all labels carefully and follow the operating procedures
- Never operate an ATV without proper instruction. Take a training course if available
- Always follow the age recommendations
- Never allow a child under 16 to operate an ATV without adult supervision, and never allow continued use of an ATV by a child if he or she does not have the abilities to operate it safely
- Never carry a passenger on an ATV.
- Never operate an ATV on any paved surfaces, including sidewalks, driveways, parking lots and streets.
- Never operate an ATV on any public street, road or highway, even a dirt or gravel one.
- Never operate an ATV without wearing an approved motorcycle helmet that fits properly.
- You should also wear eye protection, gloves, boots, long-sleeved shirt and long pants.
- Never consume alcohol or drugs before or while operating this ATV.
- Never operate this ATV at excessive speeds. Always go at a speed that is proper for the terrain, visibility and operating conditions, and your experience.
- Never attempt wheelies, jumps, or other stunts.
- Always inspect your ATV before and after each use to make sure it is in safe operating condition. Always follow the inspection and maintenance procedures and schedules described in this manual.
- Always keep both hands on the handlebars and both feet on the footrests of the ATV during operation.
- Always go slowly and be extra careful when operating on unfamiliar terrain. Always be alert to changing terrain conditions when operating the ATV.
- Never operate on excessively rough, slippery or loose terrain until you have learned and practiced the skills necessary to control the ATV on such terrain. Always be especially cautious on these kinds of terrain.
- Always follow proper procedures for turning as described in this manual. Practice turning at low speeds before attempting to turn at faster speeds. Do not turn at excessive speeds.
- Never operate that ATV on hills too steep for the ATV or for your abilities. Practice on smaller hills before attempting larger hills.
- Always follow proper procedures for climbing hills as described in this manual. Check the terrain carefully before you start up any hill. Never climb hills with excessively slipper or loose surfaces. Shift your weight forward. Never open the throttle suddenly or make sudden gear changes. Never go over the top of any hill at high speed.

SAFETY

- Always follow proper procedures for going down hills and for braking on hills as described in this manual. Check the terrain carefully before you start down any hill. Shift your weight backward. Never go down a hill at high speed. Avoid going down a hill at an angle that would cause the vehicle to lean sharply to one side. Go straight down the hill where possible.
- Always follow proper procedures for crossing the side of a hill as described in this manual. Avoid excessively slippery or loose surfaces. Shift your weight to the uphill side of the ATV. Never attempt to turn the ATV around on any hill until you have mastered the turning technique described in this manual on level ground. Avoid crossing the side of a steep hill if possible.
- Always use proper procedures if you stall or roll backwards when climbing a hill. To avoid stalling, use proper gear and maintain a steady speed when climbing a hill. If you stall or roll backwards, follow the special procedure for braking described in this manual. Dismount on the uphill side or to a side if pointed straight uphill. Turn the ATV around and remount, following the procedure described in this manual.
- Always check for obstacles before operating in a new area. Never attempt to operate over large obstacles, such as large rocks or fallen trees. Always follow proper procedures when operating over obstacles as described in this manual.
- Always be careful when skidding or sliding. Learn to safely control skidding or sliding by practicing at low speeds and on level, smooth terrain. On extremely slippery surfaces, such as ice, go slowly and be very cautious in order to reduce the chance of skidding or sliding out of control.
- Never operate an ATV in fast flowing water or in water deeper than that specified in this manual. Remember that wet brakes may have reduced stopping ability. Test your brakes after leaving water. If necessary, apply them several times to let friction dry out the linings.
- Always use the size and type tires specified in this manual. Always maintain proper tire pressure as described in this manual.
- Never modify an ATV through improper installation or use of accessories.
- Never exceed the stated load capacity for an ATV. Cargo should be properly distributed and securely attached. Reduce speed and follow instructions in this manual for carrying cargo. Allow greater distance for braking.
- The combined weight of the rider and any accessories or cargo must never exceed the vehicle's load capacity.
- Do not tow a trailer. This vehicle is not designed for such use.

MOTOWORKS 125CC FARM

LEFT VIEW

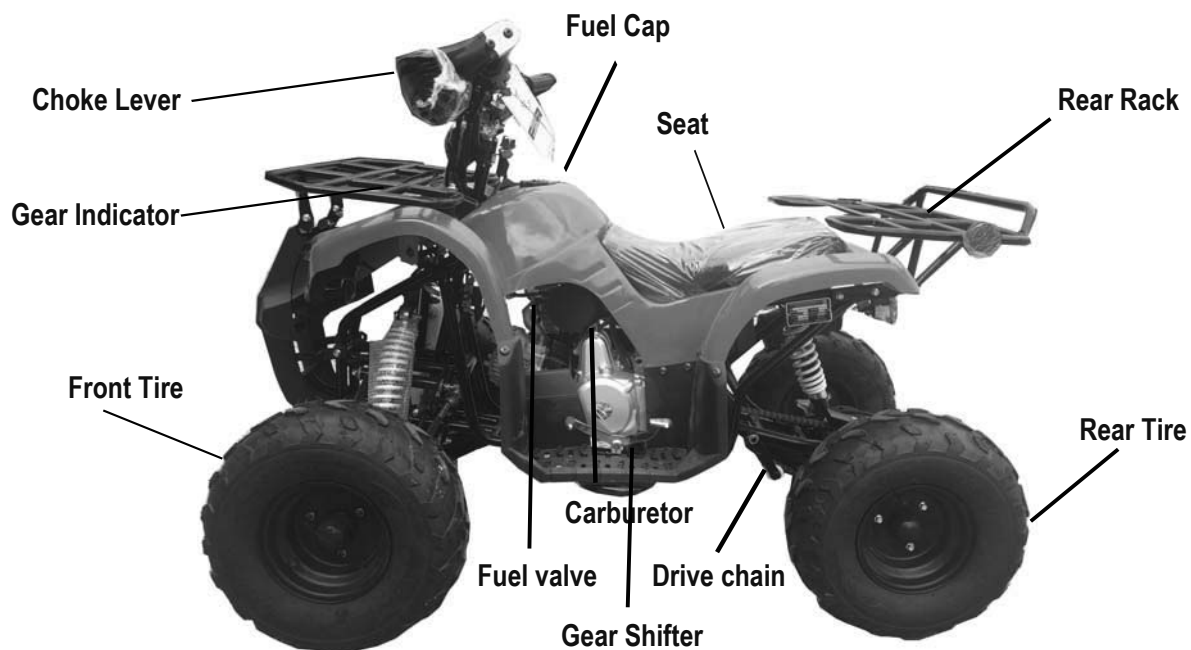

⚠ CAUTION Do Not Put Oil Into Magneto Case

RIGHT VIEW

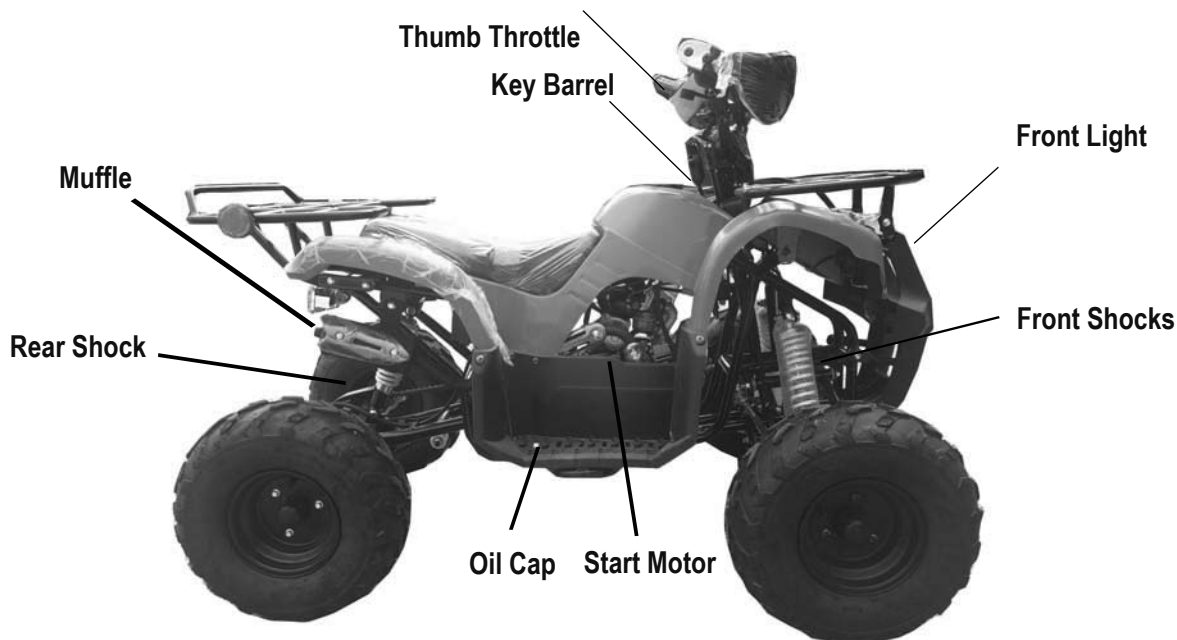

⚠ WARNING

DO NOT RIDE THE EQUIPMENT DURING THE DARKNESS
The Headlight only for position purpose. Not designed for use during the night.

MOTOWORKS 125CC FARM

DIMENSIONS AND SPECIFICATIONS

Engine:	Four Storke / Air Cooled
Cylinders:	1
Displacement:	125cc
Starting Method:	Electric Button Start
Ignition Mode:	CDI
Fuel Capacity:	3L
Fuel :	91 Unleaded
Transmission:	Auto. 1 Forward and 1 Reverse Gear
Drive System:	Rear Wheel Drive, Chain Drive
Throttle Control:	Thumb Throttle
Governor:	Throttle Speed Governor
Maximum Speed:	55km/hr
Front Brakes:	Drum Brakes
Rear Brakes:	Hydraulic Brake
Maximum Load:	90 kg
Wheels:	16x8-7" Both Front and Rear
Rider Capacity:	1 Person
Dimensions:	1340 X 1020 X 980 (mm)
Seat Height:	650(mm)
Weight:	95 kg
Oil :	SAE15W-40
Spark Plug:	A7TC
Engine operation noise	75 dB(A) AT 8500 RPM
Vibration Level	Left handle bar: 3.607 m/s ² Right handle bar: 3.208 m/s ² Seat: 7.997 m/s ²

Designs and specifications of the product are subject to change without notice. Therefore, please note that the descriptions in the manual maybe different from those for the vehicle you have purchased.

LOCATION OF LABELS

Read and follow all of the warning labels on your ATV. Make sure you understand all the labels. Keep the labels on the ATV. Do not remove them for any reason.

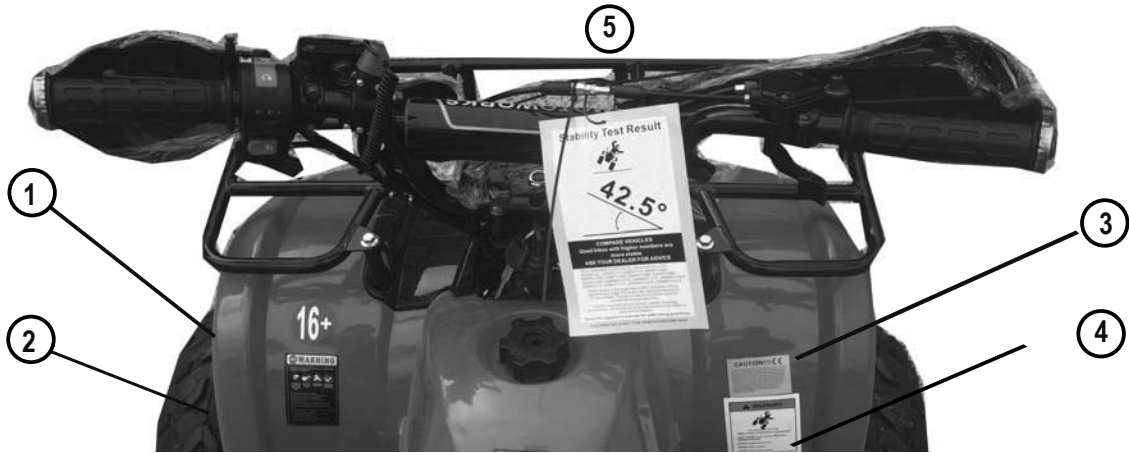

4

⚠ WARNING

RISK of ROLLOVER even on flat terrain
ROLLOVERS could result in DEATH or SERIOUS INJURY
AVOID sudden sharp turns
AVOID steep inclines
AVOID riding across slopes

3

CAUTION!!! **CE**

Riders must comply with local allowable age rules, all local laws and regulation in riding. Minors shall never operate this product without adult supervision. **DO NOT** operate this product under the influence of medical treatment and alcohol. **DO NOT** ride this product without wearing protective equipments, such as helmet, gloves, kneepads, elbow pads, and any necessary protection your local law requires. Read instructions carefully and always inspect this product prior to use to ensure it is in a safe operating condition. **DO NOT** operate this product until you can safely start, stop, turn, and yield to all obstacles environment. This product is not intended for use on public roads or highways, near water, sloped driveways or alleyways; during nighttime or bad weather conditions; or on slippery or uneven surfaces.

5

Stability Test Result

42.5°

COMPARE VEHICLES
 Quad bikes with higher numbers are more stable
ASK YOUR DEALER FOR ADVICE

WUYI QIAOWEI ELECTRICAL VEHICLE CO.,LTD
 MODEL(S): QWATV-01; QWATV-02; QWATV-02C
 QWATV-02E; QWATV-02F;
 QWATV-08F; QWMATV-01D; QWMATV-01E; QWMATV-01F;
 QWATV-12; QWMATV-01; QWMATV-01A; QWMATV-01C

When tested to the quad bike safety standard, this is the minimum angle this quad bike tipped sideways on to two wheels. The above result should be used for comparative purposes only.

Factors, such as uneven terrain, speed, loadings, accessories, modifications and rider position can effect a quad bike's stability.

Read the operator's manual for safe riding practices.

THIS HANG TAG IS NOT TO BE REMOVED BEFORE SALE

2

STOP WARNING

illegal operation ATV can result in **SEVERE INJURY or DEATH.**

ALWAYS USE AN APPROVED HELMET AND PROTECTIVE GEAR **NEVER USE ON PUBLIC ROADS** **NEVER CARRY PASSENGERS** **NEVER USE WITH DRUGS OR ALCOHOL**

An adult supervision required always.
 Overloading can adversely affect vehicle handling.
 Operator use only Passengers prohibited.
 This vehicle is designed and manufactures for OFF-ROAD use only.
 Driving on public streets, roads or highways is illegal.
 Always wear helmet and other protective equipment.
 Do not operate this vehicle after consuming Alcohol or Drugs.
 Gasoline is flammable, when refueling.
 Pls shutoffengine to avoid sparks and open flame.
 Read owner's manual carefully before riding. Keep owner's manual with vehicle.
 This bike is **NOT** designed for adult.
 This bike is **NOT** designed for steep, rocky, slippery, sandy territory and water crossing.

LOCATION OF LABELS



6



8

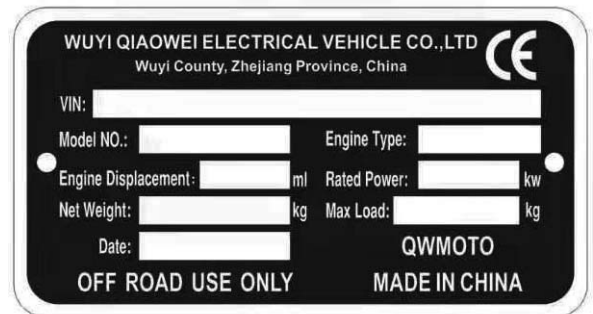

7

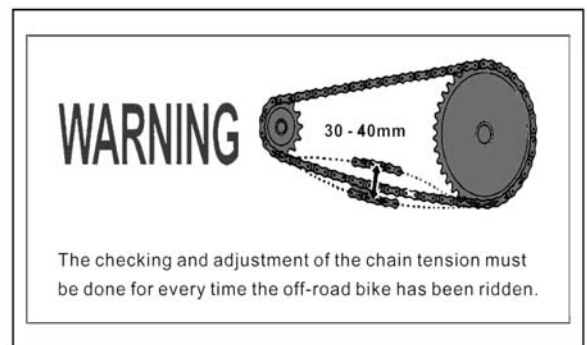

If a label comes off or becomes difficult to read, you should get a replacement by contacting your seller.

CONTROL FUNCTIONS

LEFT HANDLEBAR

When ATV is not in use, the rear brake lever should be pulled back and the parking brake pin set in place. In this position the ATV should not move.

Rear Brake Lever

Apply the rear brake by squeezing the rear brake lever towards the grip.

RUN/OFF Switch

With the switch in "RUN" position the engine can start. Move switch to "OFF" position to stop engine.

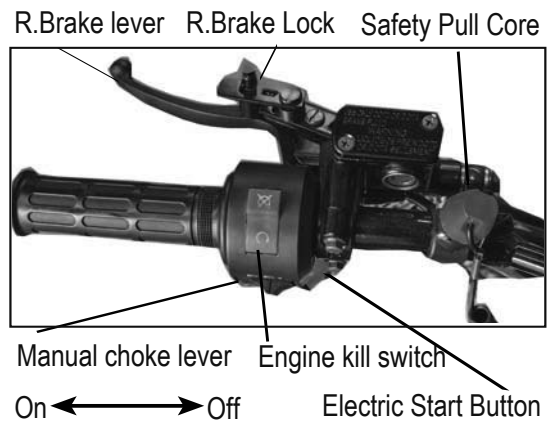

Electric Start Button

RUN/OFF switch needs to be in "RUN" position before engine will start. Push electric start button to start engine.

Parking Brake Pin

Pull in lever and push pin down in order to set the parking brake.

Manual Choke Lever

When engine is cold, place the choke lever to the "ON" position. When engine has warmed up, place choke lever back to the "OFF" position.

RIGHT HANDLEBAR

Throttle Lever

Control the engine and ATV speed with the throttle lever. Operate this lever with your thumb. Push it forward to increase engine and ATV speed. Release it to decrease engine and ATV speed.

Front brake lever

Control the engine and ATV braking with the front brake lever. Squeeze lever toward grip smoothly to apply front brakes. Release when accelerating.

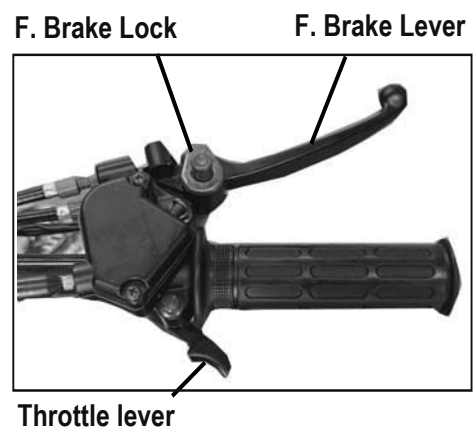

CONTROL FUNCTIONS

FUEL VALVE

This vehicle has a manually operated fuel valve. There are two positions: “ON” and “OFF”. See the pictures below for the correct operation of fuel valve.

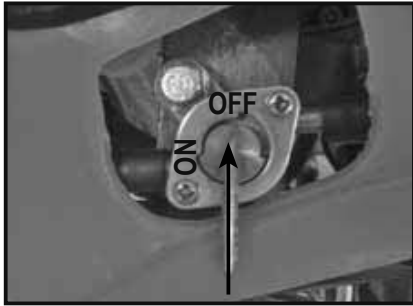

“ON” position

The fuel will flow to the carburetor when the engine is running or being started.

“OFF” position

No fuel will flow into the carburetor.

FUEL TANK CAP

To open the fuel tank cap, turn the fuel tank cap counterclockwise. To close the fuel tank cap, turn it clockwise and tighten it securely.



SEAT LOCK

To remove the seat, move the seat lock lever backward. Raise the rear end of the seat and slide it back.



Seat lock lever located under seat and rear fender

⚠ WARNING

Overfilling the fuel tank could be hazardous. If you overfill the fuel tank, fuel may overflow when it expands. Expanding is due to heat from engine or sun. Overheated fuel could easily catch fire. Stop adding fuel when the fuel level reaches the bottom of the filler neck. Failing to follow safety precautions when refueling could result in a fire or let you to breathe toxic fumes. Refuel in a well ventilated area. Make sure the engine is off and avoid spilling fuel on a hot engine. Do not smoke, and make sure there are no open flames or sparks in the area. Avoid breathing gasoline vapors. Keep children and pets away when you are refueling the ATV.

⚠ WARNING

Improperly installing the seat could be hazardous. Failing to install the seat properly could allow the seat to move and cause the rider to lose control. Make sure you are in proper position and the seat is attached securely when you install it.

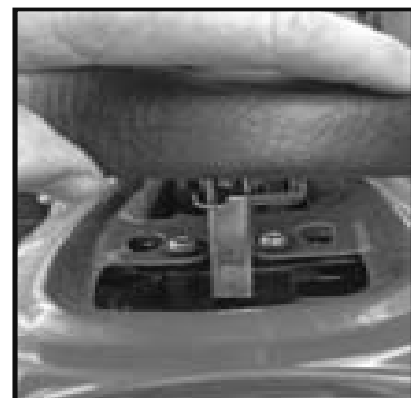

To lock the seat, slide the seat lever into its retainer and push down firmly.

RIDING YOUR ATV

WHAT YOU SHOULD KNOW BEFORE RIDING

Before riding, you should read all the following information carefully.

If you are properly prepared, you will have a more enjoyable ride.

Before riding, you should find a good place to practice the skills. Find a flat, open area with enough space to practice the new skills.

▲ WARNING

The risk of an accident is greatly increased if the operator does not know how to operate the ATV properly in different situations and on different types of terrain.

Make sure that it is legal to ride in the area you selected. Review the local laws and make sure you are not trespassing. Call the police if you don't know where you can ride.

Protect your riding areas. When you are riding, remember to keep the terrain in good condition. Don't destroy plants, trees or other vegetation. Don't litter and don't bother wildlife. With your help, your riding area can remain open for use in the future.

After you have found a good place to practice, review the control system on your ATV before riding. Learn to find these controls without looking for them, because you will not have time to look for them when you are riding.

INSPECTION BEFORE RIDING

ITEM TO CHECK	CONTENT
Steering	Smoothness; No restriction of movement; No play or looseness
Brakes	Proper brake lever free play; enough brake force; Parking brake effectiveness
Tires	Proper air pressure; Enough tread depth; No cracks, rips, or other damages
Fuel	Enough fuel for the intended trip; Fuel hose connected securely; No damage to fuel tank or cap; Fuel tank cap closed securely
Engine stop switch	Proper operation
Engine oil	Check the oil level by inspecting the Engine Oil Dipsticker. The engine oil should reach the level mark. Refill the oil if its not enough
Throttle	Proper free play of throttle lever; Smooth response; Quick return to idle position
Drive chain	Proper tension; adequate lubrication; No excessive wear or damage
General condition	Bolts and nuts are tight; No rattle from any parts of the engine when running; No visible evidence of Damage

▲ WARNING

Failing to inspect the ATV before operating could be hazardous.

Failing to perform proper maintenance could also be hazardous.

Failing to inspect and maintain your ATV could increase the chances of an accident or equipment damage

Always inspect your ATV each time before riding, and make sure it is in a safe operating condition. Refer to the INSPECTION AND MAINTENANCE section in this manual.

▲ WARNING

Checking maintenance items when the engine is running could be hazardous. You could be severely injured if your hands or clothing get caught in moving ATV parts. Shut the engine off when performing maintenance checks, except checking the engine stop switch and throttle.

BREAK-IN PROCEDURES

Proper operation during this break-in period will be helpful for assuring maximum life and performance of your new vehicle. The following guidelines explain proper break-in procedures.

Throttle Opening Recommendation

During the first 10 hours of operation, you should always use less than ½ throttle opening.

Vary the Engine Rotating Speed

This allows the parts to “load” and then “unload” (allowing the parts to cool). Although it is essential to place some stress on the engine components during break-in, you must be careful not to overload the engine.

Allow the Engine Oil to Circulate Before Riding

Allow a few minutes of idling time after warm or cold engine starting. This allows the lubricating oil to reach all critical engine components.

Break-In Maintenance

A maintenance is required after break in procedure includes proper adjustments, tightening of all bolts & nuts, and replacement of dirty oil.

STARTING THE ENGINE

Before attempting to start the engine, make sure to follow these steps.

1. Ensure the ATV is on Neutral Gear, (Gear Light is Green)
2. Turn the key switch to the "ON" position.
3. Set the engine stop switch to the “RUN“ position.
4. If engine is cold, turn choke lever
Apply the rear brake lever and make sure that the rear wheel wheels are in locking condition.
5. Press the starter button “START” to start the engine.
6. After engine has warmed up, turn choke lever back.

RIDING YOUR ATV

⚠ WARNING

The ATV could start moving as soon as you start the engine.
Unexpected Movement could cause you to lose control of the ATV
Be sure set the parking brake before you start engine.

⚠ WARNING

Running your ATV indoors where there is little or no ventilation could be hazardous.
Breathing in exhaust gases from the ATV could cause severe injury.
Always run your ATV outdoors where there is fresh air.

⚠ WARNING

Carrying a passenger on this ATV will greatly reduce your ability to balance and control this ATV. Will cause an accident, resulting in harm to you and/or your passenger.
The long seat is designed to allow the operator to shift position as needed during operation. It is not for carrying passenger.

⚠ WARNING

Never operate the ATV on any paved surfaces, including sidewalks, driveways, parking lots and streets. The ATV's tires are designed for off-road use only, not for use on pavement. Paved surfaces may seriously affect handling and control of the ATV, and may cause the vehicle to go out of control.



⚠ WARNING

Running your ATV indoors where there is little or no ventilation could be hazardous.
Breathing in exhaust gases from the ATV could cause severe injury.
Always run your ATV outdoors where there is fresh air

⚠ WARNING

Never operate this ATV on any public street, road or highway, even a dirt or gravel one. In many states it is illegal to operate ATVs on public streets, roads and highways.

⚠ WARNING

Never operate this ATV at night. Night is defined as the period of time 30 minutes before sunset to 30 minutes after sunrise.
The headlight is position light not designed for night riding

⚠ WARNING

Never attempt stunts, such as wheelies or jumps. Don't try to show off. Increases the chance of an accident, including an overturn.

RIDING YOUR ATV

⚠ WARNING

Always wear an approved motorcycle protective gear that fits properly in order to protect you from severe injury in the event of accident. **Protective Gear You shall wear:**

- eye protection (goggles or face shield)
- gloves
- boots
- long-sleeved shirt or jacket
- long pants



Wear goggles or a face shield to prevent rock or a branch hits your eyes

⚠ WARNING

Never consume alcohol or drugs before or while driving this ATV Could seriously affect your judgement. Could cause you to react more slowly. Could affect your balance and perception. Could result in an accident..

⚠ WARNING

Failure to inspect and properly maintain the ATV before operating. Increases the possibility of an accident or equipment damage.

⚠ WARNING

Failing to use extra care when operating this ATV on unfamiliar terrain. You can come upon hidden rocks, bumps, or holes, without enough time to react. Could result in the ATV overturning or going out of control. Go slowly and be extra careful when operating on unfamiliar terrain. Always be alert to changing terrain conditions when operating the ATV.

⚠ WARNING

Operating this ATV at excessive speeds increases your chances of losing control of the ATV, which can result in an accident.

⚠ WARNING

Removing even one hand or foot can reduce your ability to control the ATV or could cause you to lose your balance and fall off of the ATV. If you remove a foot from the footrest, your foot or leg may come into contact with the rear wheels, which could injure you or cause an accident.

⚠ WARNING

Opening the throttle suddenly could be hazardous.

The front wheels could leave off the ground and cause loss of control of the ATV. Always open the throttle gradually when you want to accelerate.

RIDING YOUR ATV

STARTING OFF



When you are sure that the engine is warm, release front and rear brakes.

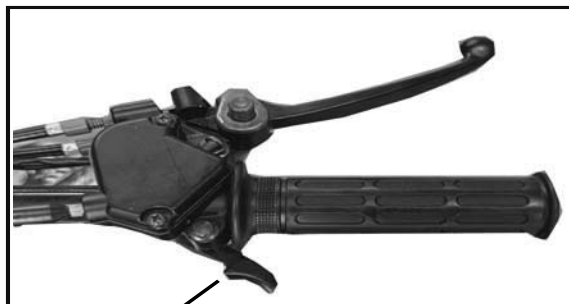

Open throttle gradually to move forward.

BRAKING



To stop the ATV, first release the throttle lever and then apply both front and rear brake smoothly.

⚠ WARNING

Braking while turning the ATV could be hazardous.

Use of the brake when turning could cause the ATV to slide or roll over. Use the brake to slow down before you begin to turn.

⚠ WARNING

Operating the parking brake when the ATV is moving could be hazardous. The front wheels could lock, and it will cause a skid and an accident.

Use the parking brake only after you stop the ATV.

⚠ WARNING

Turning improperly, the ATV could go out of control, causing a collision or overturn. Always follow proper procedures for turning as described in the owner's manual.

Practice turning at low speeds before attempting to turn at faster speeds. Do not turn at excessive speed.

RIDING YOUR ATV

TECHNIQUE TO TURN THE ATV

The ATV has a solid rear axle, both rear wheels always turn at the same speed, this means that if the rear wheels are getting equal traction, the vehicle will tend to move straight ahead.

For the ATV to turn, the outside rear wheel must travel a longer distance than the inside rear wheel. To make this happen, the rider must create less traction for the inside wheel, allowing it to skid. This allows it to travel a shorter distance than the outside wheel. This happens even though both wheels are still turning at the same speed.



- Move your body weight forward and to the inside of the turn.
- Turn the handlebar while looking in the direction of the turn.

FOR HIGHER SPEEDS OR SHARPER TURNS

Use the same technique that you use when you move your body weight farther toward the inside of the turn to maintain your balance. Natural turning forces (which can push the vehicle to the outside of the turn) increase as the speed or the turn sharpness increases. This means you must lean your body farther into the turn as you go faster or turn more sharply. This prevents the vehicle from tipping over to the outside of the turn.

If your ATV starts to tip while turning, lean your body farther into the turn while gradually reducing the throttle and making the turn wider, if possible

OPERATION ON HILLS



CLIMBING A HILL

1. Speed up and maintain a steady speed before reaching the top of the hill. Remember that you must ride at a steady speed all the way to the top of the hill.
2. Shift your body forward by sliding forward on the seat. Lean slightly forward. For steep hills, stand on the footrests and lean forward.
3. Maintain a steady speed while climbing the hill.
4. Slow down gradually when you reach the top of the hill.

RIDING YOUR ATV

⚠ WARNING

Operating on excessively steep hills can cause the ATV overturn more easily on extremely steep hills than on level surfaces or small hills. Never operate the ATV on hills too steep for the ATV or for your abilities. Practice on smaller hills before attempting larger hills.

⚠ WARNING

Going down a hill improperly could cause loss of control or cause ATV to overturn. Always check the terrain carefully before you start down any hill. Shift your weight backward.

Never go down a hill at high speed. Avoid going down a hill at an angle that would cause the vehicle to lean sharply to one side.

Go straight down the hill where possible.

⚠ WARNING

Climbing hills improperly, Could cause loss of control or cause ATV to overturn. Always follow the proper procedures for climbing hills in this owner's manual. Always check the terrain before you start up any hill.

Never climb hills with excessively slippery or loose surfaces.

Shift your weight forward

Never open the throttle suddenly or make sudden gear changes. The ATV could flip over backwards.

Never go over the top of hill at a high speed. An obstacle, a sharp drop, or another vehicle or person could be on the other side of the hill.



DESCENDING A HILL

1. Check the terrain carefully for any obstacles before you go down the hill.
2. Point the ATV straight down the hill.
3. Transfer your body to the rear by sliding back on the seat.
4. Ride down the hill slowly with the throttle released.
5. Apply the rear brake to control the speed.
6. Avoid going down a hill at an angle that would cause the vehicle to lean sharply to one side. Go straight down the hill if possible.

⚠ WARNING

Improperly crossing hills or turning on hills will cause loss of control or cause ATV to overturn. Never attempt to turn the ATV around on any hill until you have mastered the turning technique. Avoid crossing the side of a steep hill if possible. Avoid hills with excessively slippery or loose surfaces. Shift your weight to the uphill side of the ATV.

Stalling, rolling backwards or improperly dismounting while climbing a hill, could result in ATV overturning. Use proper gear and maintain steady speed when climbing a hill. If you lose all forward speed:

Keep weight uphill. Apply brakes. Lock parking brake after you are stopped.

If you begin rolling backwards:

Keep weight uphill./ Never apply the rear brake while rolling backwards. Apply the front and rear brake when fully stopped, then lock the parking brake. Dismount on uphill side or to a side if pointed straight uphill. Turn the ATV around and remount

RIDING OVER OBSTACLES

If you come to an obstacle that you cannot avoid, you may be able to cross over it by using the following procedure.

1. If the obstacle is in front of you, approach at walking speed.
2. Rise up slightly on the footrests.
3. Pull up on the handlebar and apply a little throttle as the front wheels reach the obstacle.
4. Lean forward and release the throttle after the front wheels are over the obstacle.

Remember that some obstacles are too high for your ATV or for your abilities. If you are not sure that you can safely cross over an obstacle, back up and ride around the obstacle.

SKIDDING OR SLIDING

You may experience skidding or sliding when you are not braking. You may be able to overcome it by using the techniques listed below.

If your front wheel skids:

Gain front wheel traction by reducing the throttle opening and leaning your body slightly forward.

If your rear wheel skids:

If space permits, steer in the direction of the skid. Shift your body away from the skid slightly. Avoid using the throttle or brakes until you regain directional control of the vehicle.

⚠ WARNING

Improperly operating over obstacles, will cause loss of control or a collision. Could cause the ATV to overturn.

Before operating in a new area, check for obstacles.

Never attempt to ride over large obstacles, such as large rocks or fallen trees.

⚠ WARNING

Skidding or sliding improperly, will lose control of this ATV.

You may also regain traction unexpectedly, which could cause the ATV to overturn.

Learn to safely control skidding or sliding by practicing at low speeds and on level, smooth terrain.

On extremely slippery surfaces, such as ice, go slowly to reduce the chance of skidding or sliding out of control.

RIDING YOUR ATV

RIDING THROUGH WATER

You can ride the ATV through shallow water. Make sure it is not more than 5cm deep and is not moving fast.

Choose a good place to cross before you ride through the water.

Look for a spot where the banks are gently sloped on both sides and the bottom of the stream is hard.

If you are unfamiliar with the area, park the ATV and inspect the stream first to find a suitable spot for crossing. When crossing, operate the ATV at a slow, steady speed. Be careful not to damage banks when crossing.

WARNING

Operating this ATV through deep or fast flowing water could be hazardous. The ATV tires may float losing traction and then loss of control. This could lead to an accident.
Never operate this ATV in fast flowing water or in water deeper than described in this section. Remember that wet brakes may reduce the stopping ability. Test your brakes after leaving the water. If necessary, apply the brakes several times to let friction dry out the linings

CAUTION

Operating the ATV in water, sand, or mud causes rapid brake wear
Excessive brake wear could cause the brakes to be less effective
After repeated operation of the ATV in these conditions, bring it to your authorized service center to have the brakes inspected and cleaned.

ACCESSORY USE AND VEHICLE LOADING

WARNING

This ATV is not designed to add extra accessories
Operating this ATV with improper modifications could be hazardous
Improper installation of accessories or modifications of the vehicle may cause changes in handling which could lead to an accident.

WARNING

Improper maintenance or failing to perform recommended maintenance could be hazardous. Keep your ATV in good condition. Ask your seller or a qualified mechanic to do the maintenance items marked with an asterisk (*). You may perform the unmarked maintenance items by referring to the instructions in this section if you have mechanical experience. If you are not sure how to do the maintenance ask your seller

CAUTION

If you use your ATV under severe conditions, it will need maintenance more often than shown in the chart. Operating your ATV under severe conditions causes more wear on your ATV. Severe conditions include operating under frequent full throttle, or in dusty, wet, sandy, or muddy areas. These conditions could cause the ATV to wear more quickly.

INSPECTION AND MAINTENANCE

MAINTENANCE SCHEDULE

Interval Item	Initial 1 month/ 20 hrs	Every 3 months/ 50 hrs	Every 6 months/ 100 hrs
Air Filter	—	Clean	Inspect *
Exhaust pipe & Muffler Bolts	T	Tighten	Tighten
Cylinder head	—	Clean	Clean
Spark plug	—	Clean	Replace
Engine Oil	Inspect *	Inspect *	Inspect *
Valve clearance- Check - Adjust			Inspect *
Idle Speed	Inspect *	Inspect *	Inspect *
Throttle cable	Inspect *	Inspect *	Inspect *
Fuel line	Inspect *	Inspect *	Inspect *
Brakes	Inspect *	Inspect *	Inspect *
Tires	Inspect each time before and after ride		
Drive Chain	Clean, lubricate and inspect each time the ATV is ridden		
Suspension	—	—	Inspect *
Steering	Inspect *	Inspect *	Inspect *
Chassis bolts and nuts	Tighten	Tighten	Tighten

Inspect* = Require inspect and clean, adjust, lubricate or replace, if necessary

TOOLS

- adjustable spanner
- screwdriver
- allen key
- spark Plug Socket

A tool kit is not included in the package

INSPECTION AND MAINTENANCE

SPARK PLUG

To determine if the standard spark plug is in good condition.

Check the color of the plug's center electrode insulator after vehicle operation. A brown color indicates that the plug is correct. A white or dark insulator indicates that the engine may need adjustment, or another plug type may be needed.

To install a spark plug turn it in as far as possible with your fingers, then tighten it with a wrench.

The Motoworks 125 CC Farm use A7TC Spark Plug

⚠ CAUTION

Failing to use the proper spark plug could damage your ATV.
An improper spark plug may have an incorrect fit or heat range for your engine. This may cause severe engine damage which may not be covered under warranty.

⚠ CAUTION

Dirt could damage your ATV if it entered an open spark plug hole of cylinder head. Dirt could damage engine parts that move.
Cover the spark plug hole while the spark plug is out of the hole.

⚠ CAUTION

Improper installation of the spark plug could damage your ATV.
An overly tight or cross threaded spark plug will damage the aluminum threads of the cylinder head.
Carefully turn the spark plug by hand into the threads. If the spark plug is new, tighten it with a wrench about ½ turn past finger tight. If you are reusing the old spark plug, tighten it with a wrench about 1/8 turn past finger tight

VALVE INSPECTION

Refer to maintenance schedule in this owner's manual for valve adjustment inspection intervals.

Valve clearance should be: Intake: 0.002 inch (0.05 mm)
Exhaust: 0.003 inch (0.0762 mm)

The engine will make excess noise if the gap is too large in air valve. If gap is too small valve operation will be hindered which could result in valve malfunction and failure. Therefore, air valve gap must be checked periodically.

If you need help please contact local mechanic service

INSPECTION AND MAINTENANCE

BATTERY INSTALLATION

How to Initially Charge the battery:

1. Connect the red positive (+) cable to the red positive (+) pole of the battery.(see figure 23)
2. Connect the black negative (-) cable to the black negative (-) pole of the battery. (see figure 24)
3. Charging rate: Charge battery @ 0.7 Amps for 5 ~ 10 hours.
 - Locate battery compartment on ATV. The battery compartment is located under the left rear fender.(see figure 25)
 - Remove bolts from battery compartment cover and install battery
 - Attach red positive (+) cable to positive (+) terminal on battery. Then attach black negative (-) cable to negative (-) terminal on battery.



Figure 23



Figure 24

⚠ WARNIN

DO NOT open sealed caps attempt to refill the battery.

If battery gets hot to the touch, discontinue charging and allow battery to cool down. Do not use fast charging unless it is an emergency. At the beginning or end of charging, turn off the charger first, in order to prevent electric spark and explosion.

Charge in a well ventilated area.

DO NOT smoke around batteries and keep away from open flame

Always connect battery cable in the order specified: RED first; BLACK last. An exploding battery can cause serious injury or death.

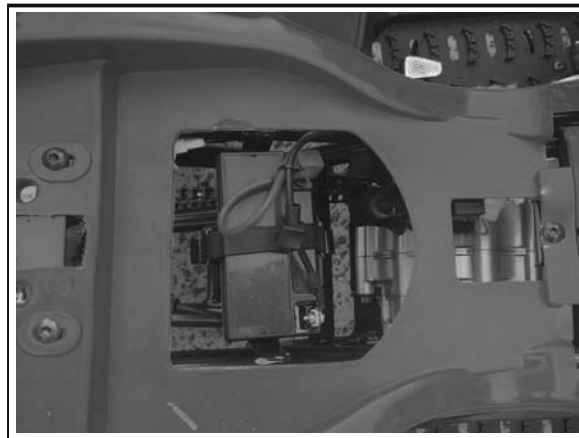

Figure 25

CHANGE BATTERY

- Remove old battery. Mark which cable is connected to the positive terminal (+) and which cable is connected to the negative (-) terminal.
- Clean cable connectors with wire brush or sandpaper to remove oxidation.
- After charging, install new battery. Put dielectric grease on the battery terminals to avoid corrosion. Connect cables to the proper terminals.

INSPECTION AND MAINTENANCE

THE ADJUSTMENT OF THROTTLE LEVER

To adjust throttle lever free distance:

1. Slide back rubber cover from adjuster nut.
2. Loosen the cinch nut. Turn the adjuster nut in or out to obtain the correct play.
3. Tighten the cinch nut
4. Recheck the throttle lever free distance. Re-adjust it if it is not within the correct limits.

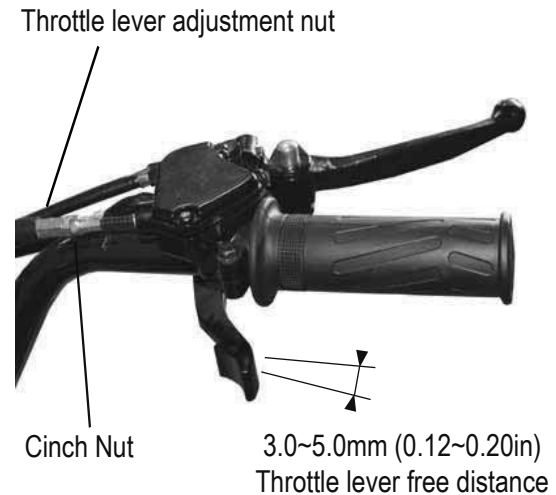

Operating the vehicle with an inadequate throttle lever free distance could be hazardous. Inadequate throttle lever free distance could cause engine speed to rise suddenly when you turn the handlebars. This can lead the rider to lose control. Adjust the throttle lever free distance so that engine idle speed does not rise due to handlebar movement.

SPEED LIMIT ADJUSTMENT

To limit the speed, screw in the throttle limiter screw

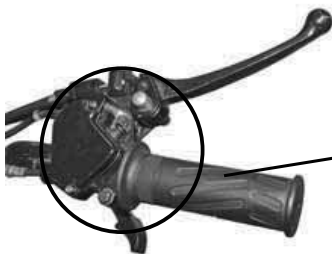

Throttle limit screw

Screw in
limit the speed
Screw out
release the setting

IDLE SPEED ADJUSTMENT

To adjust the idle speed properly, you need a tachometer. If you do not have one, ask your authorized service center to perform this adjustment.

Adjust Idle Screw

1. Start the engine and warm it up.
2. Turn the throttle stop screw in or out so that the engine idle speed is at 1400~1600r/min.



Idle adjustment screw

INSPECTION AND MAINTENANCE

⚠ WARNING

Improper adjustment of the idle speed could be hazardous.

An idle speed that is too high could cause the ATV to launch forward when you start the engine. This may cause an accident and excessive engine wear.

Adjust the idle to the correct speed. Make sure the engine is fully warm before adjusting the engine idle speed.

FUEL HOSE

Inspect the fuel hose for damage and fuel leakage. If any defects are found, the fuel hose must be replaced.

ENGINE OIL

The engine oil should be changed every 20 to 40 hours of operation. It should be changed more often in dirty and dusty areas.

To change oil:

1. Park the vehicle on level ground.
2. Remove the Foot Rest to access the oil cap
3. Remove the oil cap and oil drain bolt and drain the oil into a bucket.
4. Reinstall the oil drain bolt
5. Refill SAE 15W 40 Engine Oil. NOTE: Approximately 750ml
6. Tighten the oil cap.
7. Dispose of used oil as per governmental regulations.



Oil Cap

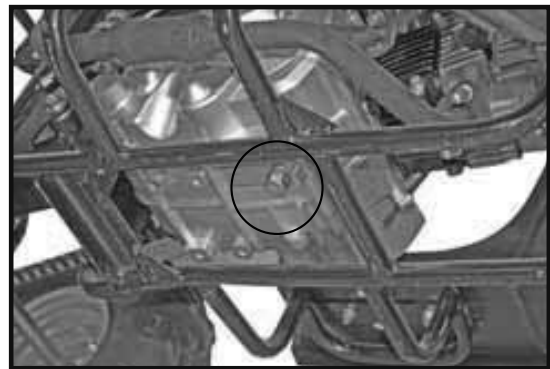

Oil Drain bolt

INSPECTION AND MAINTENANCE

⚠ WARNING

Children and pets may be harmed by swallowing new or used oil.

Continuous contact with used oil can cause skin cancer in laboratory animals.

Brief contact with the used oil may irritate the skin.

Keep new and used oil away from children and pets, wear a long-sleeve shirt and moisture-proof gloves when changing oil.

If oil contacts your skin, wash thoroughly with soap and water. Launder any clothing or rags if wet with oil.

Recycle or properly dispose of used oil.

⚠ CAUTION

Failure to use the correct oil could harm your ATV.

Running the engine without an adequate amount of engine oil could cause severe engine damage.

Always check the amount of engine oil before starting the engine.

⚠ WARNING

Operating the engine without the air cleaner element in place could be hazardous.

If the air cleaner element did not filter dirt, severe engine damage would occur if the dirt entered the running engine.

Never run the engine without the air cleaner element in place.

AIR FILTER

The air cleaner element must be kept clean to provide good engine power. If you use your vehicle under normal, low-tension conditions, you should service the air cleaner at the intervals specified. If you ride in dust, wet, or muddy conditions, you will need to inspect the air cleaner element much more frequently. Use the following procedures to remove the element and inspect it.

Remove Air Filter

1. Air Filter is accessible from side of the ATV
2. Loosen the lock ring screw, and remove

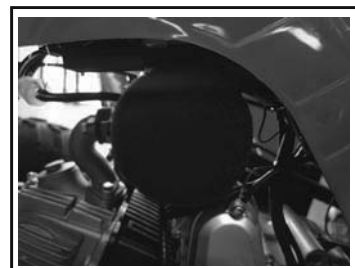

Cleaning the Air Filter

1. Tap air filter gently against hard object to remove dirt and dust.
2. Blow air filter out gently with compressed air
3. If air filter is damaged, replace
4. Re-install filter.
Any air leaks around rubber attachment could allow dirt and dust to enter the engine causing damage



INSPECTION AND MAINTENANCE

DRIVE CHAIN

The condition and adjustment of the drive chain should be checked before riding. Always follow the guidelines below for inspecting and servicing the chain.

Inspecting the Drive Chain

When inspecting the chain, look for the following:

- Loose pins
- Dry or rusted links
- Damaged rollers
- Kinked or binding links
- Excessive wear

If you find anything wrong with the drive chain, solve the problem if you can. If necessary, consult your seller.

Sprockets Check

The drive chain is damaged means that the sprockets may also be damaged.

Inspect the sprockets as specified below

- Excessively worn teeth
- Broken or damaged teeth
- Loose sprocket mounting nut(s)

Drive Chain Cleaning, Oiling and Adjustment

Chain Cleaning

Wash the chain with water. Dry the chain, and then oil the links with Chain lube or equivalent.

Chain Tension Adjustment

The drive chain should be adjusted and make sure there is **30~40 mm** of slack, as shown

1. Loosen 4 Axle Lock Bolts
2. Adjust slack in the drive chain by turning the adjusting nuts clockwise or counter clockwise to tighten or loosen.
3. When proper adjustment is obtained, tighten the axle lock bolts x 4

⚠ CAUTION

A torn air filter could damage your ATV. Dirt and dust may get inside of the engine if the element is torn.
A torn air filter could damage your ATV.

⚠ CAUTION

Air will bypass the air cleaner element if the element is not positioned properly. This will cause the engine parts to wear more rapidly. Be sure to position the air cleaner element properly.

⚠ WARNING

Riding with the chain in poor condition could lead to an accident.
Be sure to inspect and maintain the chain before riding, according to these guidelines.

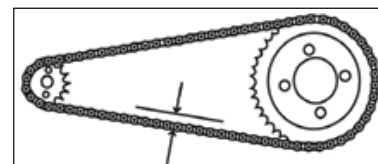

Real Axle Lock Bolts x 4

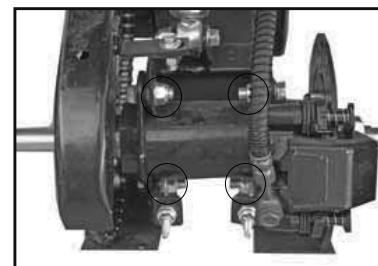

Adjusting nuts / Tensioner x 2

INSPECTION AND MAINTENANCE

WHEEL & TIRES

Tire Air Pressure

Check the air pressure in all tires before riding. Improper air pressure would effect handling, steering response, traction, tire life and rider comfort.

Be sure that the tires are inflated to the pressures shown below.

The tire pressure should only be measured or adjusted when the tires are cold.

Tire Replacement

Your ATV has low-pressure tubeless tires. Air is sealed by the contact surfaces of the inner wheel rim and the tire bead. If the inner wheel rim or tire bead is damaged, air may leak.

We are not recommend end user attempt to change the tyre at home. If do so be extremely careful not to damage these sections when replacing tires.

It is very important to use the proper tools when repairing or replacing tires in order to protect the tire bead or wheel rims. Please contact your authorized seller or qualified tire fitting station to provide tire change or seek complete wheel replace option.

Tubeless Tire Repair

If a leak or flat tire occurs due to a puncture, the tire may be repaired using a plug type patch. If the damage is from a cut, or if the puncture cannot be repaired using a plug, the tire should be replaced. When operating your ATV in areas here transportation or service facilities are not readily available, it is strongly recommended that you may consider have spare wheels.

⚠ WARNING

Failing to inspect the drive chain slack before each use of the ATV could be hazardous. Too much chain slack could cause the chain to come off the sprockets, resulting in an accident or serious damage to the ATV

Front	16x8.00-7	10 psi
Rear	16x8.00-7	10 psi

Recommended Spec:

Load 75 kg+ Speed 60 km / Hour+

⚠ WARNING

Using worn tires could be hazardous. The traction of the vehicle will be decreased. This increases your risk of having an accident.

Overfilling the air to the tires could be hazardous. If you put too much air into the tire, may burst, and causing severe injury. Check the air pressure from time to time while inflating the tire gradually, until the specified air pressure is obtained.

⚠ WARNING

Using tires that have been installed incorrectly could be hazardous. The ATV may have unusual handling if the tires are installed incorrectly. The tires are intended to rotate in a specific direction, as indicated by the arrows on the sidewall of each tire. Th Install tires correctly so they rotate in the proper direction.

INSPECTION AND MAINTENANCE

BRAKING The ATV has two front drum brakes and one rear disc brake.

⚠ WARNING

Failing to maintain the brake shoes or pads could be hazardous. Riding with worn brake shoes, pads, or shoes that are seriously worn, will increase your chance of having an accident. If you need to replace brake shoe pads, have your authorized service center do the work. Inspecting and maintaining the brake shoe pads is recommended. Replace the shoe pads in sets.

⚠ WARNING

Failing to inspect and maintain your ATV's brake system properly could be hazardous. Improper maintenance of the brake increases your chance of having an accident. Operating the ATV in harsh conditions could be hazardous if you do not inspect brake wear often. Operating in mud, water, sand, or other extreme conditions can cause accelerated brake wear. This could lead to an accident.

Front Brake Cable Adjustment

1. Try to move the vehicle backward and forward when the brake is applied. If the wheels can turn, adjust the brake to lock the wheels securely.
2. Loosen nut 1 and turn nut 2 to adjust the brake cable.
3. After any adjustment of the brake, check again to make sure the front wheels cannot turn when the brake is applied.

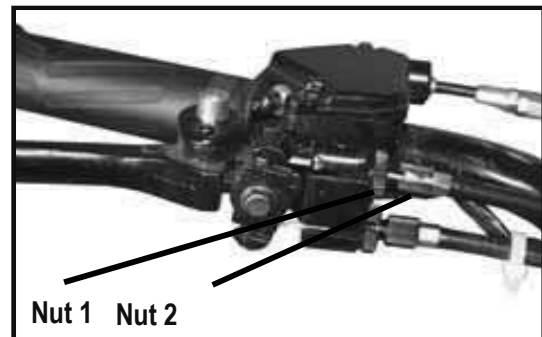

You can also adjust the front brake cable at the front wheel by the brake drum

1. Turn nut (3) clockwise to tighten the tension on the cable and counter clockwise to loosen the tension.
2. After any adjustment of the brake, check again to make sure the front wheels cannot turn when the brake is applied.



INSPECTION AND MAINTENANCE

Rear hydraulic brake inspection

1. Inspect the rear disk brake caliper and brake fluid reservoir for leakage. If brake fluid leaks, the safety of riding could be affected
2. Inspect the brake hose for cracks, and the joint for leakage.
3. Check the brake fluid level in the brake fluid reservoir, if level is at or below the LOWER mark, inspect brake pads for wear and hydraulic system for leaks.
4. To add brake fluid, unscrew the 4 screws on top of the brake fluid container. Add DOT4 brake fluid.

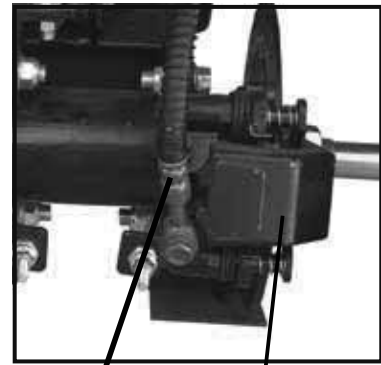

Brake fluid hose Brake Caliper

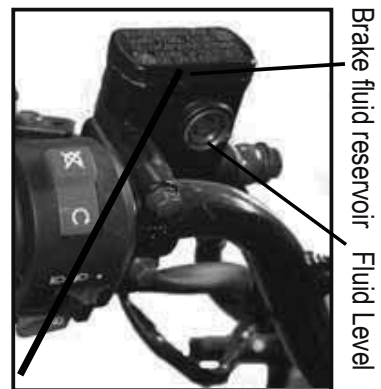

Brake fluid cap

Brake fluid reservoir
Fluid Level

TROUBLESHOOTING

ISSUE: Engine is hard to start or does not start at all. Something is probably wrong with the fuel system or ignition system.

Fuel Supplying Check

1. Make sure there is adequate fuel in the fuel tank.
2. Check that the engine stop switch is in the "RUN" position.
3. Check that the fuel valve is in the "ON" position.
4. Make sure there is enough fuel reaching the carburetor from the fuel tank.
5. Loosen the drain screw which is located under the carburetor. Drain the fuel from the carburetor into a container.
6. Tighten the drain screw.
7. Run the engine for a few seconds. Shut off engine.

⚠ CAUTION

Failing to troubleshoot a problem correctly would damage your ATV. Improper repairs or adjustments may damage the vehicle. Such damage may not be covered under warranty. If you are not sure about the proper action, consult your authorized seller about the problem.

⚠ WARNING

Draining fuel from the carburetor could be hazardous. Fuel could catch fire if you do not handle it properly. When draining the carburetor, be sure to shut the engine off. Do not smoke, and never drain or refuel in an area where there are open flames or sparks. Do not spill the fuel or you may create a fire hazard. Dispose of drained fuel properly.

TROUBLESHOOTING

8. Loosen the drain screw and check that the carburetor is filled back up with fuel.
9. If fuel is reaching the carburetor, the ignition system should be checked next.

Ignition System Check

1. Remove the spark plug and reattach it to the spark plug lead.
2. Push the electric button "START " Apply the rear brake lever to make sure the rear wheels are locked. If the ignition system is operating properly, a blue spark should jump across the spark plug gap. If there is no spark, take your machine to your service center.



⚠ WARNING

Performing the spark test improperly could be hazardous.

You could get a high voltage electrical shock if you are not familiar with this procedure.

Do not perform this check if you are not familiar with the procedure. Do not point the spark plug near the spark plug hole during this test. Do not do this test if you have a heart condition or wear a pacemaker. Do not perform this test is any near any open fuel containers for near fuel which has spilled on the ground, on the engine, or any part of the ATV.

ISSUE: Engine Stalls

1. Make sure there is enough fuel in the fuel tank.
2. Check to see that the spark plug is not fouled. Remove the spark plug and clean it. Replace it, if necessary.
3. Make sure the fuel valve is not clogged, and the fuel tank is not clogged, either.
4. Check the idle speed. If necessary, adjust it using a tachometer. The correct idle speed is 1400~1600 r/min.

TRANSPORTING

It is best to transport the ATV in the normal position.

Before transporting the ATV turn the fuel valve to the "OFF" position then drain the fuel from the carburetor as follows:

1. Drain fuel from carburetor into an empty container by loosening the carburetor drain screw.
2. When the fuel has been drained, retighten the screw

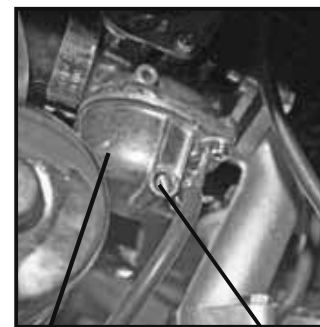

Carburetor

Drain screw

TRANSPORTING

⚠ WARNING

Draining fuel from the carburetor could be hazardous. When draining fuel from the carburetor, be sure to shut the engine off. Do not smoke, and never drain or refuel in an area where there are open flames or sparks. Do not spill the fuel or you may create a fire hazard. Dispose of the drained fuel properly.

⚠ CAUTION

Failing to secure the vehicle properly may result in an accident or damage to the vehicle. When transporting the ATV, lock the parking brake lever and tie down the vehicle securely with straps, rope, or some other suitable means. Use extra tie downs when you transport the vehicle in the standing position.

CLEANING & STORAGE

A thorough cleaning of your ATV is a necessary part of maintenance. It will help keep your ATV looking and performing best. Proper cleaning can also extend the life of your ATV.

It is important to clean and inspect your ATV after every ride, especially if it is used in mud, brush, grass, water, salt water, or very dusty conditions.

The build-up of mud, brush, grass, etc. especially on the engine and exhaust system, can reduce engine cooling ability, conceal damage, or increase wear of certain parts. It is important to remove all debris during cleaning.

PREPARATION FOR CLEANING

Wash the ATV before any mud dries on the ATV. Block or seal the end of the exhaust pipe (muffler) using a piece of plastic wrap, cloth rag or another method to prevent water from entering engine.

⚠ CAUTION

High pressure washers could damage your ATV. It may cause rust, corrosion and increase wear.

WASH THE ATV

With some care, your ATV can be washed in a similar manner to washing an automotive

Note: Avoid spraying or allowing water to flow over the following places

- Ignition switch · Fuel tank cap · Air Filter · Spark plug · Carburetor

Use a garden hose at low pressure to remove the majority of dirt or other debris. Hand wash your ATV with mild soap or detergent and water. Try to thoroughly remove all dirt and debris without excessive water pressure, even at remote areas such as between engine cooling fins, linkages or mounting brackets. Cloth rags, washing mitts or cleaning brushes can be used. Be careful with brushes as they may scratch plastic or painted surfaces. Rinse the ATV thoroughly with clean water. Dry all areas using a chamois or soft absorbent cloth.

CLEANING & STORAGE

INSPECTION AFTER CLEANING

Remove the rags or wrapping from the exhaust pipe.

Follow the procedures in the INSPECTION BEFORE RIDING section to check your ATV for any problems that may have occurred during your last ride.

If you do not use your ATV for a long time, it will need special service requiring appropriate materials, equipment and skill. For this reason, we recommend that you trust this maintenance work to your authorized service center. If you wish to service the machine for storage yourself, follow the general guidelines below:

CLEANING

Place the vehicle on level ground and wash the entire vehicle.

FUEL

Drain the fuel from the fuel tank by a hand pump. Drain the fuel from the carburetor by releasing the carburetor drain screw.

TIRES

Inflate tires to the normal pressure

EXTERNAL

1. Spray all vinyl and rubber parts with rubber protection.
2. Spray unpainted surfaces with rust preventative.
3. Coat painted surfaces with car wax.

PROCEDURE FOR RETURNING TO SERVICE

1. Clean the entire vehicle.
2. Make sure that the vehicle is properly lubricated.
3. Perform the INSPECTION BEFORE RIDING as listed in this manual.
4. Start the vehicle as outlined in this manual.

⚠ WARNING

Operating the ATV with wet brakes could be hazardous.

Wet brakes may not provide as much stopping power as dry brakes. This could lead to an accident.

Test your brakes after washing the ATV, riding at a slow speed. If necessary, apply brake several times to let the friction dry out the linings.

⚠ WARNING

Draining the fuel could be hazardous. Fuel could catch fire if you do not handle it properly.

When draining the fuel from the fuel tank, be sure to shut the engine off. Do not smoke, and never drain fuel in an area where there are open flames or sparks. Keep pets and children away from the fuel, and dispose of the drained fuel properly.

WIRING DIAGRAM

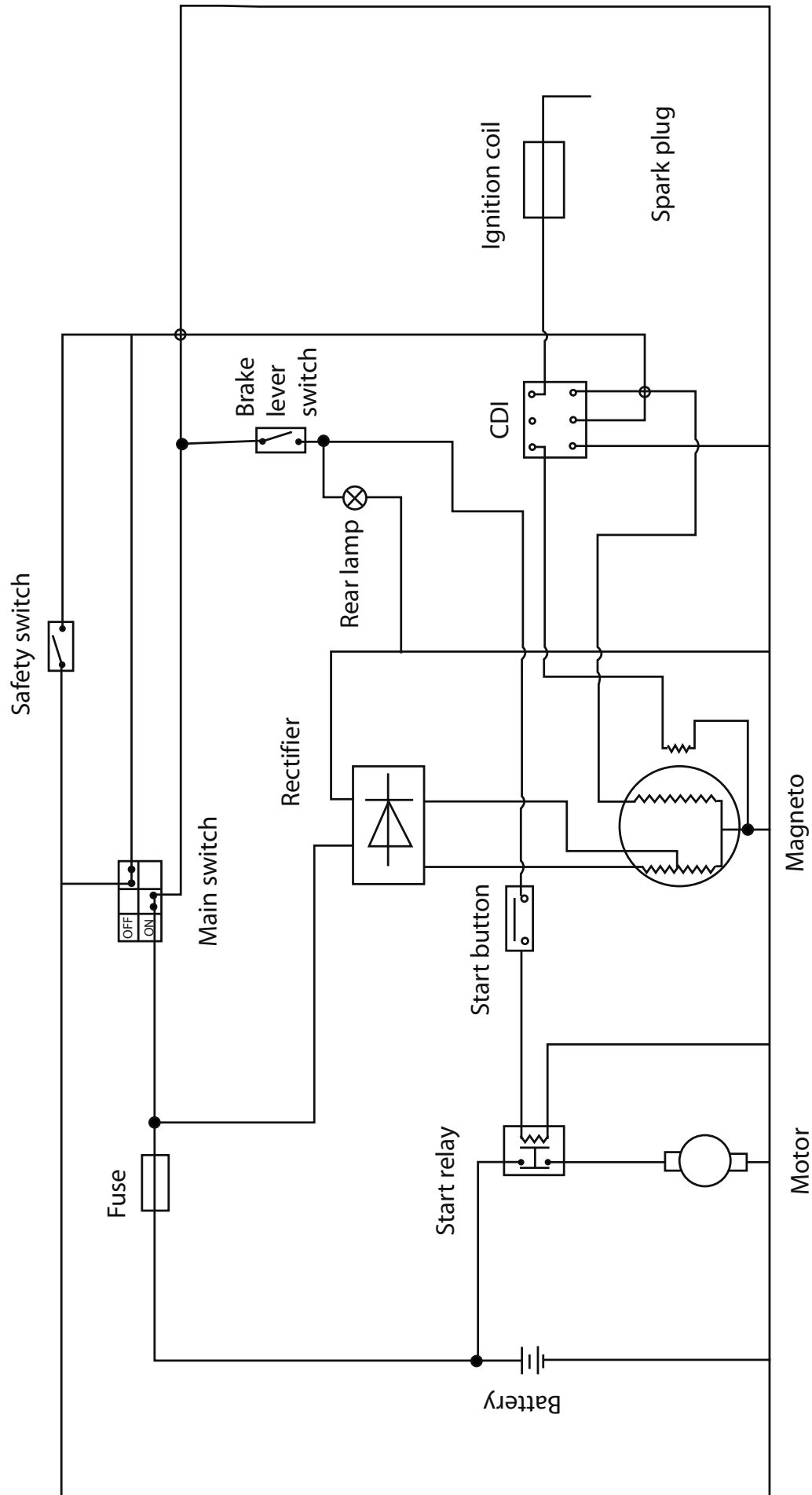

WARRANTY & LIABILITY

OWNER'S WARRANTY RESPONSIBILITIES

As the vehicle owner, you are responsible for the performance of the required maintenance. You should maintain a record of all maintenance performed on your vehicle and retain all receipts covering maintenance on your vehicle. You may not be denied a warranty claim solely because of your failure to ensure the performance of all scheduled maintenance or lack of maintenance records or receipts. You are responsible for presenting your vehicle to an authorized dealer as soon as a problem exists. The warranty repairs should be completed in a reasonable amount of time, not to exceed 30 days.

As the vehicle owner, you should be aware that you may be denied your warranty coverage if your vehicle or a part has failed due to abuse, neglect, improper maintenance, or unapproved modifications

WARRANTY COVERAGE

The Distributor warrants that each new 2020 and later vehicle:

- is designed, built, and equipped in compliance to Australia Standard at the time of initial retail purchase
- is free from defects in material and workmanship which cause such vehicle to fail to conform with applicable regulations

Coverage of repairs under this warranty applies only when repairs are completed at an authorized dealer or repair facility. The Distributor will not cover repairs performed outside of an authorized dealer or repair facility. The use of replacement parts not equivalent to the original parts may impair the effectiveness of your vehicle's emission control system. If such a replacement part is used and an authorized dealer determines it is defective or causes a failure of a warranted part, your claim for repair to bring your vehicle into compliance with applicable standards may be denied.

The liability of the Distributor under this Warranty is limited solely to the remedying of defects in material workmanship by an authorized dealer at its place of business during customary business hours. This warranty does not cover inconvenience or loss of use of the vehicle or transportation of the vehicle to/from the authorized dealer. The Distributor is not liable to any person for incidental, consequential or special damages of any description, whether arising out of express or implied warranty or any other contract, negligence or other tort or otherwise.

WARRANTY & LIABILITY

EXCLUSIONS AND LIMITATIONS

This warranty does not cover the following:

- Failures or malfunctions of the emission control systems caused by abuse, alteration, accident, misuse, the use of leaded gasoline.
- Replacement of expendable maintenance items unless they are original equipment defective in material or workmanship under normal use, and the first required replacement interval for the item has not been reached. Expendable maintenance items include but not limited to spark plugs, filters, coolant, lubricants, gaskets and hoses.
- Replacements of parts and other services and adjustments for required maintenance.
- Repairs or replacements as a result of: Accident or Misuse
- Use of replacement parts or accessories not conforming to the original specifications which adversely affect performance.
- Physical damage, corrosion, or defects caused by fire, explosions or similar causes beyond the control of the Distributor.
- Use of the vehicle in any type of competitive racing or related events immediately and completely voids this and all other warranties.

Evaluation Sheet

Table L.1 — Evaluation sheet before letting a person use the ATV

Points to be checked	Yes	No	Points to be checked	Yes	No
First checks			Emergency manoeuvres the maximum speed of the vehicle		
Can the person reach the footrests			Front and rear brakes satisfactory		
Does he have a good lateral vision (make the panoramic test)			Direction of vision satisfactory		
First exercises			Position of the ATV satisfactory		
Can move the ATV without using it, walking beside it			On a slope		
Can park the ATV, activate the parking brake			Can perform a U turn		
Familiarity with the controls, correct use			Can drive down the slope		
Can set correctly rear view mirrors			Good distribution of the body weight		
Can use the lights			Awareness of special situations		
Can use clutch			Impact of meteorological conditions		
Can use the gearbox			Wary of driving errors or dangerous behaviour putting the immediate safety of the rider or other persons at risk		
Can use the accelerator			Behaviour satisfactory during use in normal situations (after explanations by the supervisor)		
Can use the braking systems			Cornering using body weight		
First manoeuvres (make 2 at reduced speed, among which one slalom)			Driving down a slope		
Can use the clutch in conjunction with the brake			Climbing slopes		
Balance satisfactory			Driving down a slope		
Direction of vision satisfactory			Crossing a slope horizontally		
Driving technique satisfactory			Driving on rough terrain		
Gear selection technique satisfactory			Skidding and wheel spin		

Pre-delivery Inspection Checklist

If you collect the assembled bike from Motoworks Australia or local dealer please ask for a signed pre-delivery certificate.

For online order or pick up product in original package and conduct self assembling please use following table to conduct a self check before use the product

Set-Up Items Completed as Specified in Assembly Guide:	✓
Install Handlebar	
Install Wheels	
Verify Tire Pressure	
Replace Packing Engine Oil	
Charge and Install Battery	
Verify Fluid Levels	
Add Gasoline	
Check all bolts and nuts	
Check all wiring connection	
Check all cable	
Adjust Chain	
Test all electrical components	
General check after assembling	

If you notice parts are missing, experiencing difficult to complete the assembling or notice something is wrong please contact your seller.

You may need provide following support information:

- Clear description of the concerns
- Photos of the equipment
- Provide your contact details for seller technician to contact you
- Proof of purchase

WARNING SIGN



Do not use this vehicle on public roads



Do not carry passengers on this vehicle



Never use drugs or alcohol



Do not carry more than one passenger on this vehicle



Tyre pressure



Use from 6 years old



Use from 10 years old



Use from 12 years old



Use from 16 years old



Use personal protective equipment



Read instructions handbook



Towing device: horizontal force limitation



Towing device: Vertical force limitation

▲ CAUTION

Indicates a potential hazard that could result in vehicle damage

▲ WARNING

Indicates a potential hazard that could result in death or injury